

Instruction manual

Operating & Maintenance

4812163901_A.pdf

Vibratory roller
CC900G

Engine
Honda GX630RH QYD

Serial number
10000303xxA023833 -



Translation of original instruction

Table of Contents

Introduction	1
The machine	1
Intended use	1
Warning symbols.....	1
Safety information	1
General	2
Safety - General instructions.....	5
Safety - when operating	7
Work driving	7
Driving near edges	8
Seated position	8
Special instructions	9
Standard lubricants and other recommended oils and fluids	9
Higher ambient temperatures, above +40°C (104°F).....	9
Lower ambient temperature - Freeze risk	9
Temperatures.....	9
High pressure cleaning	9
Fire fighting	10
Roll Over Protective Structure (ROPS)	10
Battery handling	10
Jump starting.....	11
Technical specifications	13
Vibrations - Operator station	13
Noise level.....	13
Slopes	13
Dimensions, side view.....	14
Dimensions, top view	15
Weights and volumes.....	16
Working capacity.....	16
General	16

Hydraulic system	17
Tightening torque	18
ROPS - bolts	19
Machine description	21
Gasoline engine	21
Electrical system	21
Propulsion system/Transmission	21
Brake system	21
Steering system	21
ROPS	21
Identification	22
Product and component plates	22
Machine plate	22
Product identification number on the frame	23
Engine plates	24
Decals	25
Location - decals	25
Location - decals, CALIFORNIA	26
Safety decals	26
Info decals	29
Instruments/Controls	29
Locations - Instruments and controls	29
Function description	30
Electrical system	31
Relays and fuses on the machine	31
Operation	33
Before starting	33
Operator's seat - Adjusting	33
Sprinkler - Check	33
Parking brake	34

Emergency stop	34
Operator position.....	34
Starting	35
Starting the engine	35
Driving	36
Operating the roller	36
Interlock/Emergency stop/Parking brake - Check	37
Vibration	37
Manual vibration - Switching on	37
Braking	37
Service brake	38
Reserve brake	38
Switching off	39
Parking	39
Chocking the drums	39
Miscellaneous	41
Locking the articulation	41
Lifting the roller.....	41
Unlocking the articulation	41
Securing CC900G for loading	42
Retractable ROPS (Optional).....	43
Towing	44
Releasing the brake	45
Towing the roller.....	46
Operating instructions - Summary	47
Preventive maintenance	49
Acceptance and delivery inspection.....	49
Warranty.....	49
Maintenance - Lubricants and symbols	51
Maintenance symbols	53

Maintenance - Maintenance schedule	55
Service and maintenance points	55
General	56
Every 10 hours of operation (Daily).....	56
After the first 20 hours of operation.....	57
After the FIRST 50 hours of operation	57
Every 50 hours of operation	57
Every 100 hours of operation	57
Every 200 / 400 / 600 / 800 hours of operation	58
Every 500 hours of operation	58
Every 1000 hours of operation	59
Every 2000 hours of operation	60
Maintenance, 10h	61
Engine - Checking the oil level.....	61
Hydraulic reservoir, Level check - Filling.....	61
Refueling	62
Water tank - Filling	62
Sprinkler system - Check, cleaning.....	62
Air circulation - Check	63
Scrapers - Check, adjustment.....	63
Warning lamps - Check.....	64
Air cleaner - check	64
Maintenance - 20h	65
Engine oil and oil filter - Change	65
Maintenance - 50h	67
Brakes - Check.....	67
Air cleaner - cleaning	68
Rubber elements and fastening screws - Check.....	68
Maintenance - 100h	69
Spark plug - Check and adjustment	69

Maintenance - 200 / 400 / 600 / 800 h	71
Spark plug - Replace.....	71
Engine's fuel filter - Check.....	72
Hydraulic fluid cooler - Cleaning (Option)	72
Engine oil and oil filter - Change	73
Forward/Reverse controls and joints - Check and lubrication	74
Maintenance - 500h	75
Front drum - Checking the oil level	75
Hydraulic reservoir - Check/venting	76
Steering joint - Check.....	76
Air cleaner - replace insert	77
Maintenance - 1000h	79
Spark plug - Replace.....	79
Engine's fuel filter - Check.....	80
Hydraulic fluid cooler - Cleaning (Option)	80
Forward/Reverse controls and joints - Check and lubrication	81
Front drum - Checking the oil level	82
Hydraulic reservoir - Check/venting	82
Steering joint - Check.....	83
Air cleaner - replace insert	83
Hydraulic fluid filter - Change	84
Engine oil and oil filter - Change	84
Engine's fuel filter - Check.....	85
Maintenance - 2000h	87
Spark plug - Replace.....	87
Engine's fuel filter - Check.....	88
Hydraulic fluid cooler - Cleaning (Option)	88
Forward/Reverse controls and joints - Check and lubrication	89
Hydraulic reservoir - Check/venting	89
Steering joint - Check.....	90

Air cleaner - replace insert	90
Hydraulic fluid filter - Change	91
Engine oil and oil filter - Change	91
Engine's fuel filter - Check.....	92
Hydraulic reservoir - fluid change.....	93
Front drum - Changing the oil	94
Water tank - Cleaning	94

Introduction

The machine

Dynapac CC900G is a vibratory tandem roller in the 1,3 metric tonnes class featuring 900 mm wide drums. The machine is equipped with drive and brakes on both drums, and vibration on front drum.

Intended use

CC900G is primarily used for smaller compaction works, such as minor roads, sidewalks, cycle ways and minor parking places.

Warning symbols



WARNING ! Marks a danger or a hazardous procedure that can result in life threatening or serious injury if the warning is ignored.



CAUTION ! Marks a danger or hazardous procedure that can result in damage to the machine or property if the warning is ignored.

Safety information



It is recommended to at least train operators in handling and daily maintenance of the machine in accordance with the instruction manual. Passengers are not allowed on the machine, and you must sit in the seat when operating the machine.



The safety manual supplied with the machine must be read by all roller operators. Always follow the safety instructions. Do not remove the manual from the machine.



We recommend that the operator reads the safety instructions in this manual carefully. Always follow the safety instructions. Ensure that this manual is always easily accessible.



Read the entire manual before starting the machine and before carrying out any maintenance.



Replace immediately the instruction manuals if lost, damaged or unreadable.



Ensure good ventilation (extraction of air by fan) where the engine is run indoors.

CALIFORNIA

Proposition 65

Decal and location of decal shown in section Machine description.

⚠ WARNING: Operating, servicing and maintaining a passenger vehicle or off-road vehicle can expose you to chemicals including engine exhaust, carbon monoxide, phthalates, and lead, which are known to the State of California to cause cancer and birth defects or other reproductive harm. To minimize exposure, avoid breathing exhaust, do not idle the engine except as necessary, service your vehicle in a well-ventilated area and wear gloves or wash your hands frequently when servicing your vehicle. For more information go to www.P65Warnings.ca.gov/passenger-vehicle.

General

This manual contains instructions for machine operation and maintenance.

The machine must be correctly maintained for maximal performance.

The machine should be kept clean so that any leakages, loose bolts and loose connections are discovered at as early a point in time as possible.

Do not spray with high-pressure cleaner directly onto gaskets and bearing spacings in steering hitch and drum, and electronics.

Inspect the machine every day, before starting. Inspect the entire machine so that any leakages or other faults are detected.

Check the ground under the machine. Leakages are more easily detected on the ground than on the machine itself.



THINK ENVIRONMENT ! Do not release oil, fuel and other environmentally hazardous substances into the environment. Always send used filters, drain oil and fuel remnants to environmentally correct disposal.

This manual contains instructions for periodic maintenance, where maintenance after every 10 and 50 hours of operation can be performed by the machine operator. Other maintenance intervals must be carried out by accredited (Dynapac) service personnel.



Additional instructions for the engine can be found in the manufacturer's engine manual.

Specific maintenance and checks on combustion engines must be carried out by the engine supplier's certified personnel.

Safety - General instructions

(Also read the safety manual)



- **The operator must be familiar with the contents of the OPERATION section before starting the roller.**
- **Ensure that all instructions in the MAINTENANCE section are followed.**
- **Only the operator is allowed to be on the roller. Remain seated at all times when operating the roller.**
- **Never use the roller if it is in need of adjustment or repair.**
- **Only ascend and descend the roller when it is stationary. Use the intended footsteps, grips and rails. Always use the three-point grip (both feet and one hand, or one foot and both hands) when ascending or descending the machine. Never jump down from the machine.**
- **Dynapac always recommends mounted ROPS (Roll Over Protective Structure), or a ROPS-approved cab and seat belt usage.**
- **Drive slowly in sharp bends.**
- **Avoid driving across slopes. Drive straight up or straight down the slope.**
- **Never operate with roller outside the edge, if the substrate does not have full bearing strength or is close to a slope. Avoid operating close to edges and ditches and the like as well as on poor ground conditions that jeopardizes the bearing strength and capacity to support the roller.**
- **Make sure that there are no obstacles in the direction of travel, on the ground, in front of or behind the roller, or overhead.**
- **Drive particularly carefully on uneven ground.**
- **Keep the roller clean. Clean any dirt or grease that accumulates on the operator platform immediately. Keep all signs and decals clean and legible.**
- **Safety measures before refueling:**
 - **Stop the engine**
 - **Do not smoke.**
 - **No naked flames in the vicinity of the roller.**
 - **Earth the filling equipment nozzle to the tank opening to avoid sparks.**
- **Before repairs or service:**
 - **Chock the drums/wheels.**
 - **Lock the articulation if necessary.**
 - **Place blocks under overhanging equipment, such as strike-off blade and chip spreader.**
- **Hearing protection is recommended if the noise level exceeds 80 dB(A). The noise level can vary depending on the equipment on the machine and the surface the machine is being used on.**

- **Do not make any changes or modifications to the roller that could affect safety. Changes are only to be made after written approval has been given by Dynapac.**
- **Avoid using the roller before the hydraulic fluid has reached its normal working temperature. Braking distances can be longer than normal when the fluid is cold. See instructions in the STOP section.**
- **For your own protection always wear:**
 - helmet
 - working boots with steel toecaps
 - ear protectors
 - reflecting clothing/high visibility jacket
 - working gloves
- **If the machine seems to be responding abnormally during travel, stop and check it.**

Safety - when operating



Prevent persons from entering or remaining in the danger area, i.e. a distance of at least 7 m (23 ft) in all directions from operating machines. The operator may allow a person to remain in the risk zone, however he/she must be attentive and operate the machine only when the person is fully visible or has given a clear indication of where he or she is.



Avoid driving across a slope. Drive straight up and down sloping ground.

Work driving

Avoid operating close to edges and ditches and the like as well as on poor ground conditions that jeopardizes the bearing strength and capacity to support the roller. Pay attention to potential obstacles above the machine, such as overhead cables and the branches of trees etc.

Pay particular attention to the stability of the substrate when compacting close to edges and holes. Do not compact with a large overlap from the previous track in order to maintain roller stability. Consider other compaction methods such as remote-control or a walk-behind roller close to steep slopes or where the bearing strength of the substrate is unknown.



Dynapac always recommends mounted ROPS (Roll Over Protective Structure) and seat belt usage.

On machines with foldable ROPS, make sure that the ROPS is correctly mounted in the upright position during all operation.

Driving near edges



Never operate with roller outside the edge, if the substrate does not have full bearing strength or is close to a slope.



Keep in mind that the machine's center of gravity moves outwards when steering. For example, the center of gravity moves to the right when you steer to the left.

Seated position

Remain seated at all times when operating the roller.



Always use the seat belt where fitted. Where the seat belt is not used, there is a great risk that the operator will be thrown off and land under the machine if the machine topples over.

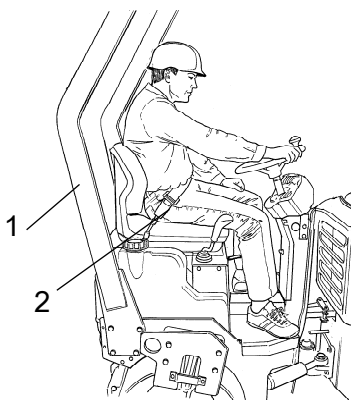

Figure. Seat position
1. ROPS
2. Seat belt

The seat belt is standard equipment on rollers fitted with Roll Over Protective Structure (ROPS) (1).



ROPS should always be in the raised position when machines with foldable ROPS are operated

Special instructions

Standard lubricants and other recommended oils and fluids

Before leaving the factory, the systems and components are filled with the oils and fluids specified in the lubricant specification. These are suitable for ambient temperatures in the range -15°C to +40°C (5°F - 105°F).



The maximum ambient temperature for biological hydraulic fluid is +35°C (95°F).

Higher ambient temperatures, above +40°C (104°F)

For operation of the machine at higher ambient temperatures, although maximum +50°C (122°F), the following recommendations apply:

The gasoline engine can be run at this temperature using normal oil. However, the following fluids must be used for other components:

Hydraulic system - mineral oil Shell Tellus T100 or equivalent.

Lower ambient temperature - Freeze risk

Make sure that the watering system is empty/drained of water (sprinkler, hoses, tank/s) or that anti-freeze has been added, to prevent the system freezing.

Temperatures

The temperature limits apply to standard versions of rollers.

High pressure cleaning

Do not spray water directly onto electrical components or the instrument panels.

Place a plastic bag over the fuel filler cap and secure with a rubber band. This is to avoid high pressure water entering the vent hole in the filler cap. This could cause malfunctions, such as the blocking of filters.

Do not spray with high-pressure cleaner directly onto gaskets and bearing spacings in steering hitch and drum, and electronics.



Never aim the water jet directly at the fuel tank cap, or into exhaust pipe. This is particularly important when using a high-pressure cleaner.

Fire fighting

If the machine catches fire, use an ABC-class powder fire extinguisher.

A BE-class carbon dioxide fire extinguisher can also be used.

Roll Over Protective Structure (ROPS)



Never carry out any welding or drilling in the Roll Over Protective Structure (ROPS).



Never repair a damaged ROPS structure, it must be replaced with a new one.

Battery handling



When removing batteries, always disconnect the negative cable first.



When fitting batteries, always connect the positive cable first.



Dispose of old batteries in an environmentally friendly way. Batteries contain toxic lead.



Do not use a quick-charger for charging the battery. This may shorten battery life.

Jump starting

 **Do not connect the negative cable to the negative terminal on the dead battery. A spark can ignite the oxy-hydrogen gas formed around the battery.**

 **Check that the battery used for jump starting has the same voltage as the dead battery.**

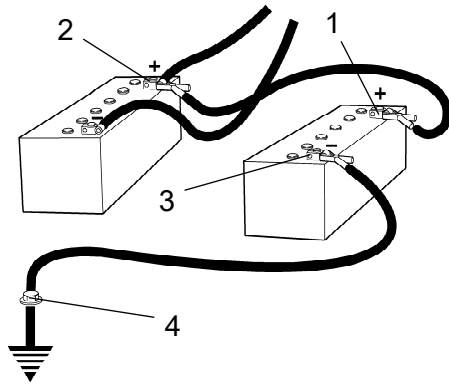

Fig. Jump starting

Turn the ignition and all power consuming equipment off. Switch off the engine on the machine which is providing jump start power.

First connect the jump start battery's positive terminal (1) to the flat battery's positive terminal (2). Then connect the jump start battery's negative terminal (3) to, for example, a bolt (4) or the lifting eye on the machine with the flat battery.

Start the engine on the power providing machine. Let it run for a while. Now try to start the other machine. Disconnect the cables in the reverse order.

Technical specifications

Vibrations - Operator station (ISO 2631)

The vibration levels are measured in accordance with the operational cycle described in EU directive 2000/14/EC on machines equipped for the EU market, with vibration switched on, on soft polymer material and with the operator's seat in the transport position.

Measured whole-body vibrations are below the action value of 0.5 m/s^2 as specified in Directive 2002/44/EC. (Limit is 1.15 m/s^2)

Measured hand/arm vibrations also were below the action level of 2.5 m/s^2 specified in the same directive. (Limit is 5 m/s^2)

Noise level

The noise level is measured in accordance with the operational cycle described in EU directive 2000/14/EC on machines equipped for the EU market, on soft polymer material with vibration switched on and the operator's seat in the transport position.

Guaranteed sound power level, L_{WA} 102 dB (A)

Sound pressure level at the operator's ear (platform), L_{pA} 84 \pm 3 dB (A)

During operation the above values may differ because of the actual operational conditions.



Max 20° or 36%

Slopes

This angle has been measured on a hard, flat surface with the machine stationary.

The steering angle was zero, the vibration was switched OFF and all tanks were full.

Always take into consideration that loose ground, steering the machine, vibration on, machine speed across the ground and raising the center of gravity can all cause the machine to topple at smaller slope angles than those specified here.

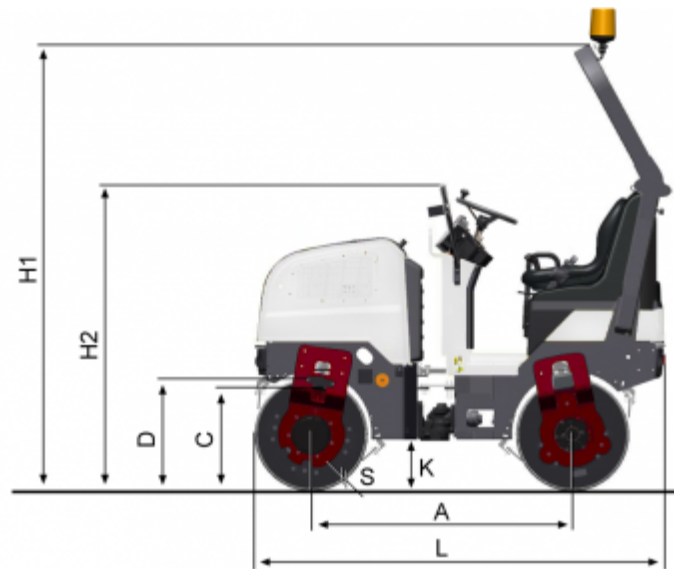
Dimensions, side view

	Dimensions	mm	in
A	Wheelbase	1350	53,1
D	Drum diameter	584	23,0
H ₁	Height, with ROPS	2300	90,5
H ₂	Height, w/o ROPS	1585	62,4
K	Ground clearance	261	10,3
L	Length	2107	83,0
S	Drum shell thickness	9	0,35

Dimensions, top view

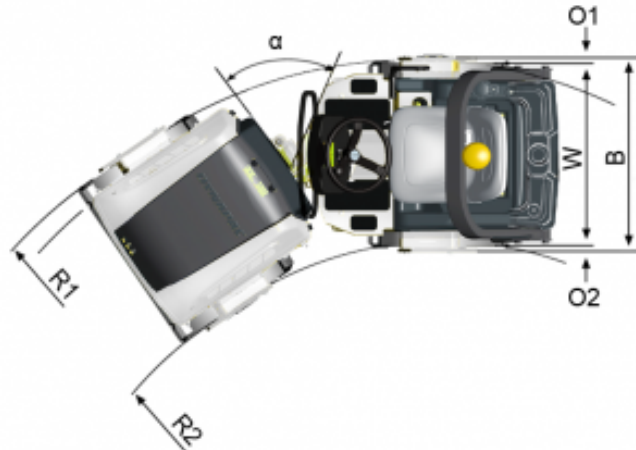

	Dimensions	mm	in
B	Width	970	38,2
O	Overhang	35	1,38
R ₁	Turning radius, outside	2700	106,3
R ₂	Turning radius, inside	2660	104,7
W	Drum shell thickness	900	35,4
α	Steering angle	±34°	±34°

Weights and volumes

Weights

Operating mass (ISO6016)	1250 kg	2767 lbs
--------------------------	---------	----------

Fluid volumes

Fuel tank	23 liters	6,0 gal
Water tank	190 liters	50 gal

Working capacity

Compaction data

Static linear load, front	6 kg/cm	33.6 pli
Static linear load, rear	7,8 kg/cm	43.7 pli
Amplitude	0,4 mm	0.016 in
Vibration frequency	70 Hz	4200 rpm
Centrifugal force	16,7 kN	3752 lb

Note: The frequency is measured at high revs. The amplitude is measured as the real value and not the nominal.

Propulsion

Speed range	0-8	kph	0-5	mph
Climbing capacity (theoretical)	35	%		

General

Engine

Manufacturer/Model	Honda GX630RH QYD
Output at 3,600 rpm (SAE J1349)	15,5 kW / 21 Hp

Electrical system

Battery	12V 60Ah
Charging coil	12V 20A
Fuses	See the Electrical system section - fuses

Hydraulic system

Opening pressure	MPa	Psi
Drive system	27,0	3915
Supply system	2,0	290
Vibration system	22,0	3190
Control systems	7,0	1015
Brake disengagement	2,0	290

Tightening torque

Tightening torque in Nm for oiled or dry bolts tightened with a torque wrench.

Metric coarse screw thread, bright galvanized (fzb):

STRENGTH CLASS:

M - thread	8.8, Oiled	8.8, Dry	10.9, Oiled	10.9, Dry	12.9, Oiled	12.9, Dry
M6	8,4	9,4	12	13,4	14,6	16,3
M8	21	23	28	32	34	38
M10	40	45	56	62	68	76
M12	70	78	98	110	117	131
M14	110	123	156	174	187	208
M16	169	190	240	270	290	320
M20	330	370	470	520	560	620
M22	446	497	626	699	752	839
M24	570	640	800	900	960	1080
M30	1130	1260	1580	1770	1900	2100

Metric coarse thread, zinc-treated (Dacromet/GEOMET):

STRENGTH CLASS:

M - thread	10.9, Oiled	10.9, Dry	12.9, Oiled	12.9, Dry
M6	12,0	15,0	14,6	18,3
M8	28	36	34	43
M10	56	70	68	86
M12	98	124	117	147
M14	156	196	187	234
M16	240	304	290	360
M20	470	585	560	698
M22	626	786	752	944
M24	800	1010	960	1215
M30	1580	1990	1900	2360

ROPS - bolts

Bolt dimensions :	M12 (PN 4700508063)
Strength class :	8.8
Tightening torque :	70 Nm



ROPS-bolts which are to be torque tightened must be dry.

Machine description

Gasoline engine

The machine is equipped with a air-cooled, four-stroke, gasoline engine with V-twin design and horizontal axle.

Electrical system

The machine has the following control units (ECU, Electronic Control Unit) and electronic units.

- Main ECU (for the machine)

Propulsion system/Transmission

The propulsion system is a hydrostatic system with a hydraulic pump supplying two motors connected in parallel.

The motors drive the front and rear drums.

The speed of the machine is proportional to the deflection/angle of the control lever from neutral.

Brake system

The brake system consists of a service brake, secondary brake and parking brake.

The service brake is hydrostatic and is activated by moving the control lever to neutral.

Secondary/Parking brake

The secondary and parking brake system consists of sprung multiple disc brakes in the motors. The brakes are released with hydraulic pressure and are operated with a switch on the instrument panel.

Steering system

The steering system is a hydrostatic system.

The control valve on the steering column distributes the flow to the control cylinder, which actuates the articulation.

The steering angle is proportional to the deflection of the steering wheel.

ROPS

ROPS is the abbreviation for "Roll Over Protective Structure".

If any part of the cab's or the ROPS structure's protective construction displays plastic deformation or cracks, the cab or the ROPS structure must be replaced immediately.

Never perform unauthorized modifications on the

ROPS structure without first having discussed the modification with Dynapac's production unit. Dynapac determines whether the modification could result in the approval according to the ROPS standards becoming invalid.

Identification

Product and component plates

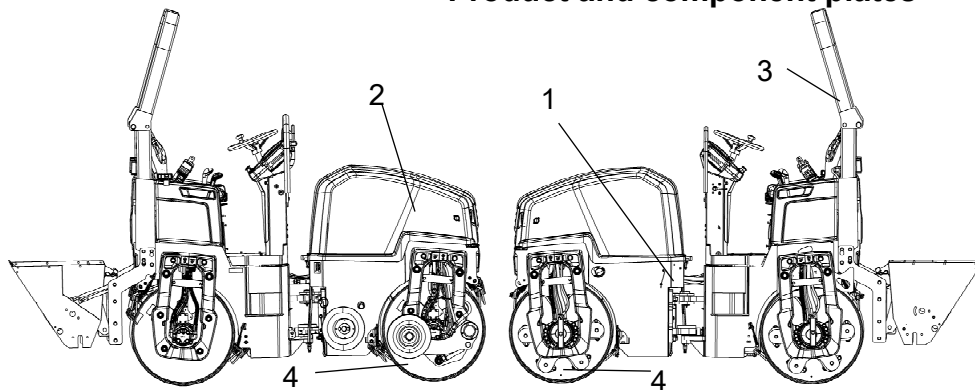

1. Product plate - Product Identification Number (PIN), model/type designation
2. Engine plate - Type description, product and serial numbers
3. ROPS plate - Certification, product and serial numbers
4. Component plate, drum - Product and serial numbers

Machine plate

The machine plate (1) is attached to the front left side of the rear frame, beside the steering joint.

The plate specifies the manufacturers name and address, the type of machine, the PIN, Product Identification Number (serial number), operating weight, engine power and year of manufacture. CE markings and the year of manufacture may be omitted on machines supplied to markets outside the EU.

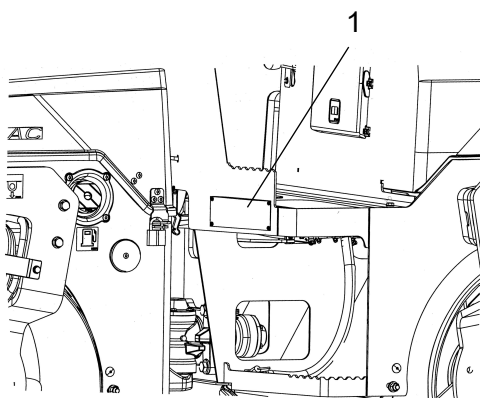





Fig. Operator's platform, left side
1. Machine plate

 optional QR code		 Dynapac Compaction Equipment AB Box 504, SE-371 23 Karlskrona Sweden		
Product Identification Number		XXXXXXXXXXXXXXXXXX		
Designation	Type	Rated Power	Max axle load front / rear	
XXXXXX	XXXXXX	XXX kW	XXXX/XXXX kg	
Gross machinery mass	Operating mass	Max ballast	[Date of Mfg]	
XXXX kg	XXXX kg	XXXX kg	XXXX	
Made in Sweden				
<small>4011 0001 33</small>				

Please state the machine's PIN when ordering spares.

Product identification number on the frame

The machine PIN (Product Identification Number) (1) is punched on the right edge of the front frame.

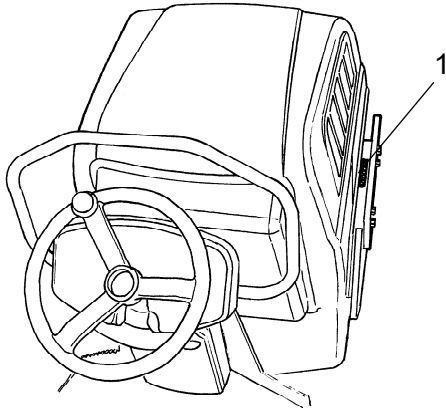

Fig. PIN Front frame

Engine plates

The engine serial number (1) is punched below the starter.

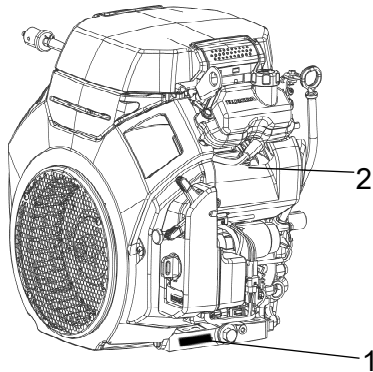
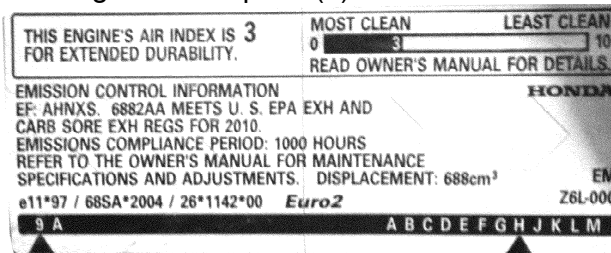

Figure. Engine
1. Serial number
2. EPA plate (USA)

Please specify the engine serial number when ordering spares. Refer also to the engine manual.

The engine's EPA plate (2).



Decals

Location - decals

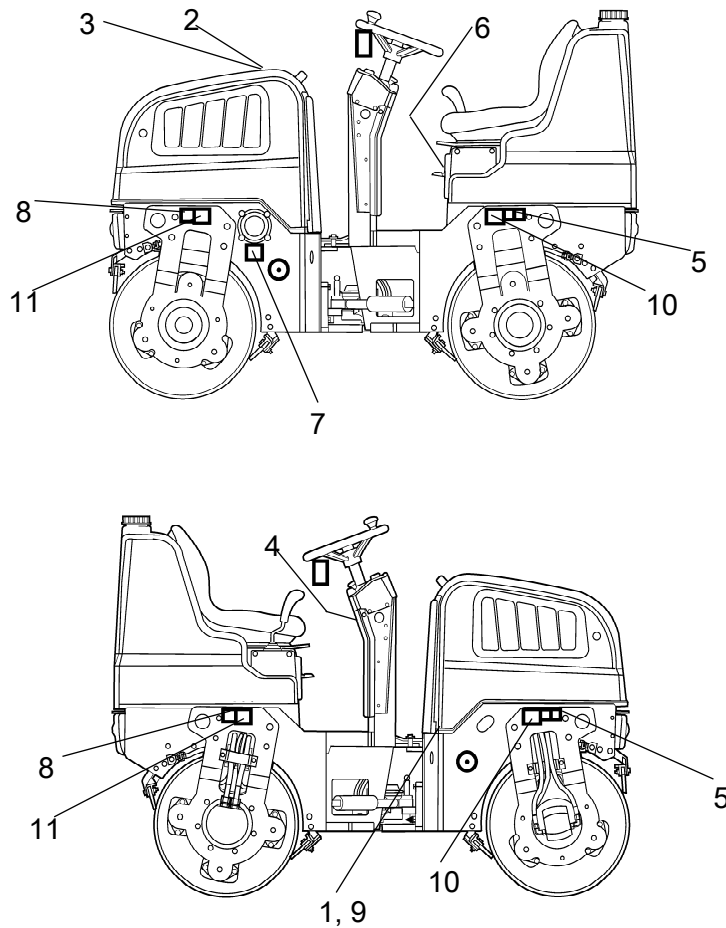

Fig. Location, decals and signs

1.	Warning, Crush zone	4700903422	8.	Lifting point	4700357587
2.	Warning, Rotating engine components	4700903423	9.	Hydraulic fluid level	4700272373
3.	Warning, Hot surfaces	4700903424	10.	Hoisting plate	4700904870
4.	Warning, Instruction manual	4700903459	11.	Fixing point	4700382751
5.	Warning, Locking	4700908229			
6.	Handbook compartment	4700903425			
7.	Gasoline fuel	4700381371			

Location - decals, CALIFORNIA

Proposition 65

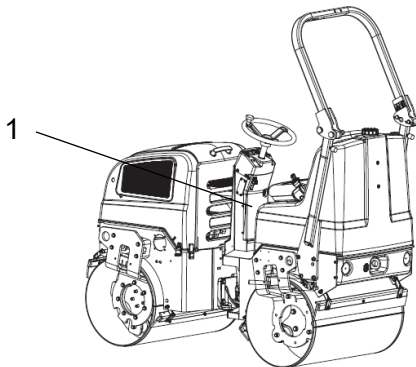
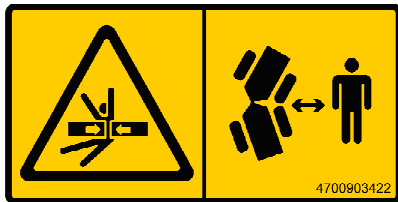

Fig. Location

- | | | |
|----|------------------------------------|------------|
| 1. | Warning, CALIFORNIA Proposition 65 | 4812130471 |
|----|------------------------------------|------------|

Safety decals

Always make sure that all safety decals are completely legible, and remove dirt or order new decals if they have become illegible. Use the part number specified on each decal.



4700903422
Warning - Crush zone, articulation/drum.

Maintain a safe distance from the crush zone.
(Two crush zones on machines fitted with pivotal steering)

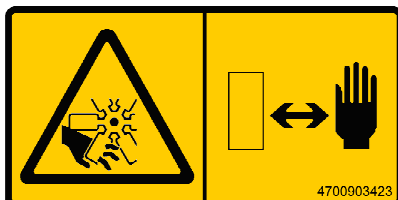

4700903423
Warning - Rotating engine components.

Keep your hands at a safe distance.

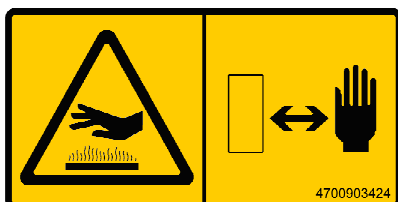

4700903424
Warning - Hot surfaces in the engine compartment.

Keep your hands at a safe distance.



4700903459
Warning - Instruction manual

The operator must read the safety, operation and maintenance instructions before operating the machine.

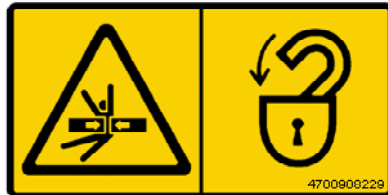

4700908229
Warning - Risk of crushing

The articulation must be locked when lifting.

Read the instruction manual.

4812130471
Warning

CALIFORNIA - Proposition 65



WARNING

Operating, servicing and maintaining a passenger vehicle or off-road vehicle can expose you to chemicals including engine exhaust, carbon monoxide, phthalates, and lead, which are known to the State of California to cause cancer and birth defects or other reproductive harm. To minimize exposure, avoid breathing exhaust, do not idle the engine except as necessary, service your vehicle in a well-ventilated area and wear gloves or wash your hands frequently when servicing your vehicle.

For more information go to
www.P65warnings.ca.gov/passenger-vehicle

4812130471

Info decals

Handbook compartment



Gasoline



Lifting point

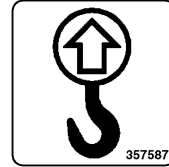

Hydraulic oil level

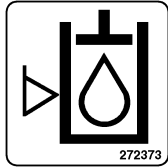

Hoisting plate

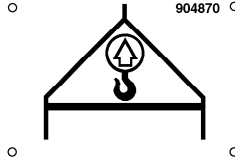

Securing point

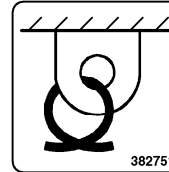

Instruments/Controls

Locations - Instruments and controls

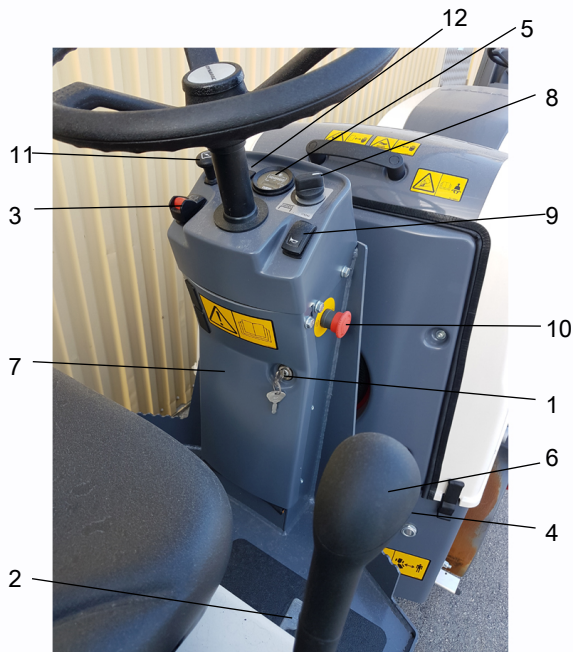







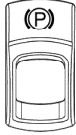

- 1. Ignition key
- 2. Control, engine speed
- 3. Parking brake
- 4. Vibration on/off, switch
- 5. Fuel level, Hour meter
- 6. Forward/Reverse lever

- 7. Fuse box
- 8. Sprinkler
- 9. Horn
- 10. Emergency stop
- 11. Choke
- 12. Parking brake warning lamp, Hydraulic oil temperature (not in use)

Fig. Instruments and control panel

Function description

No	Designation	Symbol	Function
1.	Starter switch		<p>The electric circuit is broken.</p> <p>All instruments and electrical controls are supplied with power</p> <p>Starter motor activation.</p>
2.	Control, engine speed		<p>Pull the lever up to obtain idling speed. Move the lever down to obtain working speed.</p>
3.	Parking brake		<p>To activate the brakes, press the top of the switch to change the position of the switch.</p> <p>To release the brakes, press down the red part at the same time as the switch and change the position of the switch.</p>
4.	Vibration On/Off. Switch		<p>When the switch for vibrations in the forward/reverse lever is pressed and released, the vibrations are engaged. Press the switch again to disengage the vibrations.</p>
5.	Fuel level, Hourmeter		<p>Shows the fuel level and the number of hours the engine has run.</p>
6.	Forward/Reverse lever		<p>The lever must be in neutral to start the gasoline engine. The engine cannot be started if the forward/reverse lever is in any other position.</p> <p>The forward/reverse lever controls both the roller's driving direction and speed. When the lever is moved forward, the roller moves forward etc.</p> <p>The roller's speed is proportional to the distance the lever is from the neutral position. The further the lever is from the neutral position, the higher the speed.</p>
7.	Fuse box (on control column)		<p>Contains fuses for the electrical system. See under the heading 'Electrical system' for a description of fuse functions.</p>
8.	Sprinkler, control		<p>Turn the knob clockwise to switch on the water flow to the drum.</p>
9.	Horn, switch		<p>Press to sound the horn.</p>
10.	Emergency stop		<p>Brakes the roller and switches off the engine. The power supply goes off.@@</p> <p>NOTE: The emergency stop must be deactivated when starting the machine.</p>
11.	Choke		<p>Used in the pulled out position if necessary when the engine is started.</p>
12.	Parking brake warning lamp, Hydraulic oil temperature (not in use)		<p>The light comes on when the Parking brake is activated.</p> <p>Hydraulic oil temperature lamp is not valid while not in use.</p>

Electrical system

Relays and fuses on the machine

The figure shows the positions of the various fuses and relays. The table below gives their amperage and function. All fuses are flat pin fuses.

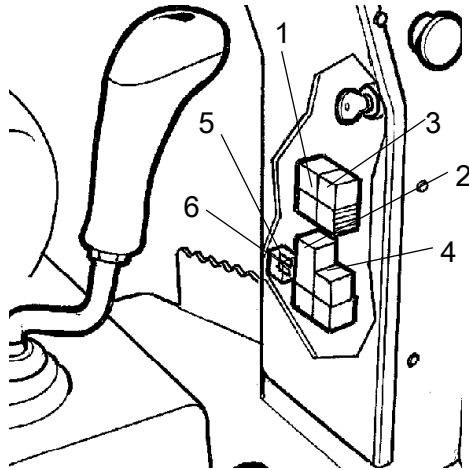

Relays			
1.	K1	Starting	12V 30A
2.	K2	Start, vibration, brake	12V 15A
3.	K22	Cooling fan, hydraulic system (Option)	12V 30A
4.	K20	Drive restriction relay	12V 10A

Fuses		
5.	7.5A	Start/stop valve Fuel pump Restriction relay VBS relay Vibration
6.	15A	Horn Backup alarm Fan (Option)

Fig. Control column

Operation

Before starting

Operator's seat - Adjusting

Adjust the operator's seat so that the position is comfortable and so that the controls are within easy reach.

The seat can be adjusted lengthways (1).

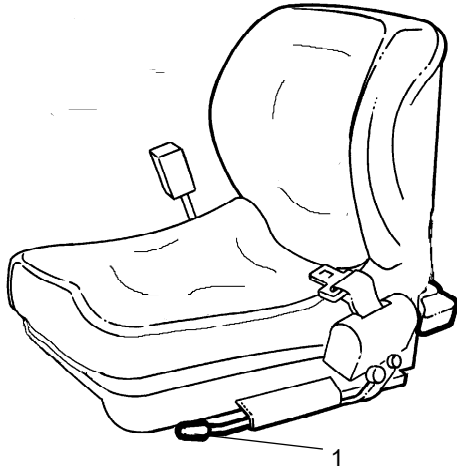

Fig. Operator's seat
1. Length adjustment

Sprinkler - Check



Make sure that the parking brake (3) is activated.



Figure. Instrument panel
1. Ignition key
3. Parking brake
8. Switch, sprinkler

Set the knob (8) for the sprinkler in the open position and check that the drums are watered.

Parking brake



Activate the parking brake (3) before leaving the machine.



The machine can be started with the parking brake deactivated.

Emergency stop

The machine can only be started if the emergency stop (10) is deactivated.

Figure. Control panel
3. Parking brake
10. Emergency stop

Operator position

If a ROPS (Roll Over Protective Structure) (2) is fitted to the roller, always wear the seat belt (1) provided and wear a protective helmet.



Replace the seat belt (1) if it shows signs of wear or has been subjected to high levels of force.



Ensure that the anti-slip (3) on the platform is in good condition. Replace where anti-slip friction is poor.

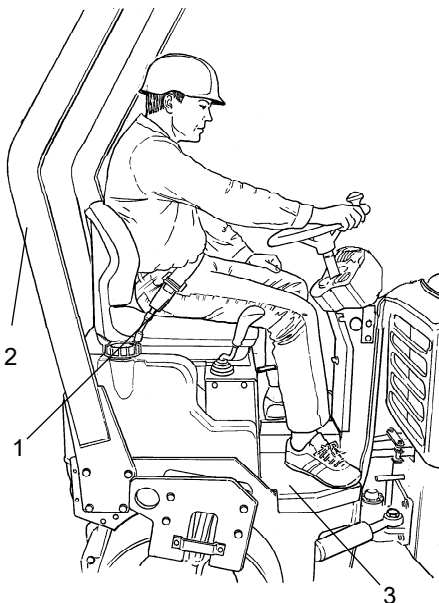

Fig. Operator's station
1. Seat belt
2. ROPS (Optional)
3. Anti-slip

Starting

Starting the engine

Make sure that the parking brake (3) is activated.

Sit down in the operator's seat and set the forward/reverse lever (6) in neutral. You cannot start the gasoline engine with the lever in any other position.

Set the RPM control (2) to idle.

For cold start: Pull out the choke (11) and turn the ignition key to position II. Check that the warning lamps on the control panel are working. Turn the ignition key (1) to the right. As soon as the engine has started, release the ignition key.



Do not run the starter motor for too long. If the engine does not start immediately, wait a minute or so before trying again.

Warm up the engine at idling speed for a few minutes, although longer if ambient temperature is below +10 C (50 F). Push in the choke as soon as possible.

When the engine is warm, check that the parking brake warning lamp (12) is still lit.



When starting and driving a machine that is cold, remember that the hydraulic fluid is also cold and that braking distances can be longer than normal until the machine reaches the working temperature.



Ensure that there is good ventilation (air extraction) if the engine is run indoors. Risk of carbon monoxide poisoning.



Figure. Control panel

- 1. Starter switch
- 2. Speed control
- 3. Parking brake
- 6. Forward/Reverse lever
- 11. Choke



Fig. Instrument panel

- 12. Parking brake warning lamp

Driving

Operating the roller



Under no circumstances is the machine to be operated from the ground. The operator must be seated at the machine during all operation.

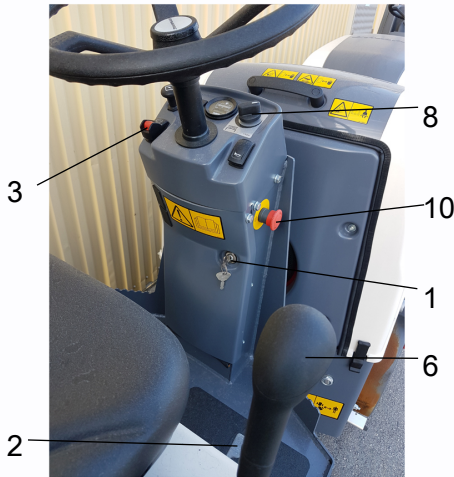

Figure. Instrument panel

- 1. Starter switch**
- 2. Speed control**
- 3. Parking brake**
- 6. Forward/Reverse lever**
- 8. Sprinkler knob**
- 10. Emergency stop**

Move the speed control (2) down to its working position.

Deactivate the parking brake (3). Be prepared that the roller can move.

Check that the steering is working correctly by turning the steering wheel once to the right and once to the left while the roller is stationary.

When compacting asphalt, remember to turn on the sprinkler system (8).



Make sure that the area in front of and behind the roller is clear.

Carefully move the forward/reverse lever (6) forwards or backwards, depending on which direction of travel is required.

Speed increases as the lever is moved away from the neutral position.



The speed should always be controlled using the forward/reverse lever and never by changing the engine speed.



Test the function of the reserve brake by activating the parking brake (3) while the roller is moving slowly forwards and backwards.

Check when operating that the warning lamps do not come on.

Interlock/Emergency stop/Parking brake - Check



The interlock, emergency stop and parking brake must be checked daily before operating. A function check of the interlock and emergency stop requires a restart.



The interlock function is checked by the operator standing up from the seat when the roller is moving very slowly forwards/backwards. (Check in both directions). Hold the steering wheel firmly and brace yourself for a sudden stop. A buzzer goes on and after 4 seconds the engine switches off and the brakes are activated.



Check the function of the emergency stop by pressing the emergency stop when the roller is moving slowly forwards/backwards. (Check in both directions). Hold the steering wheel firmly and brace yourself for a sudden stop. The engine switches off and the brakes are activated.



Check the function of the parking brake by activating the parking brake when the roller is moving very slowly forwards/backwards. (Check in both directions). Hold the steering wheel and brace yourself for a sudden stop when the brakes are activated. The engine does not switch off.

Vibration

Manual vibration - Switching on



Vibration should not be active when the roller is stationary. This can damage both the surface and the machine.

Engage and disengage vibration using the switch (4) on the underside of the forward/reverse lever.

Always switch off vibration before the roller comes to a standstill.



**Fig. Forward/Reverse lever
4. Switch, vibration On/Off**

Braking

Service brake



When starting and driving a machine that is cold, remember that the hydraulic fluid is also cold and that braking distances can be longer than normal until the machine reaches the working temperature.

Press the switch (4) to switch off the vibration.

Move the forward/reverse lever (6) to the neutral position to stop the roller.



Never leave the operator platform without activating the parking brake (3).

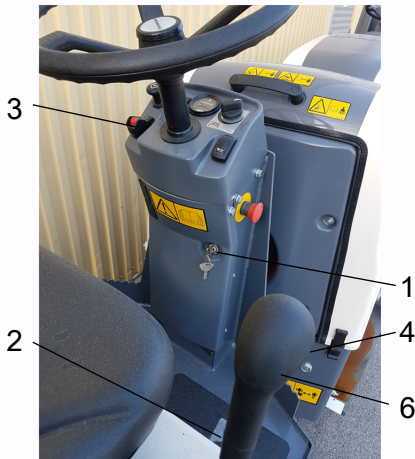

Fig. Control panel
1. Starter switch 2. Speed control
3. Parkering brake
4. Vibration On/Off
6. Forward/Reverse lever

Reserve brake

Braking is normally activated using the forward/reverse lever. The hydrostatic transmission retards and slows the roller when the lever is moved towards the neutral position.

A disc brake in each drum motor acts as reserve brake when in motion and as a parking brake when stationary.



To brake in an emergency situation, press in the emergency stop (10), hold the steering wheel firmly and be prepared for a sudden stop.

After braking, return the forward/reverse lever to the neutral position and pull out the emergency stop (10).



Activate the parking brake (3) before leaving the machine.



Fig. Controls
3. Parking brake
10. Emergency stop



Fig. Instrument panel
1. Starter switch
2. Engine speed control
3. Parking brake

Switching off

Turn the engine speed control (2) back to idling. Allow the engine to idle for few minutes to cool.

Activate the parking brake (3).

Turn the starter switch (1) to the left to shut off position.

Parking

Chocking the drums



Never leave the operator platform without activating the parking brake.



Make sure that the roller is parked in a safe place with respect to other road users. Chock the drums if the roller is parked on sloping ground.

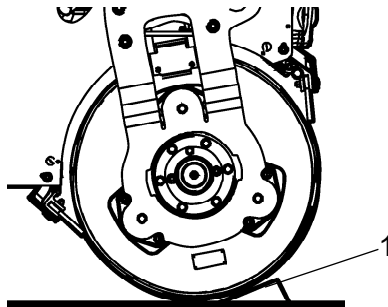

Fig. Set-up
1. Chocks



Keep in mind that there is a risk of freezing during the winter. Drain the water tanks and water lines.

Miscellaneous

Locking the articulation

Turn the steering wheel to the straight ahead position.

Raise the locking arm (1) and turn 180 degrees downward. Ensure that the cotter pin (2) is guided into its lower position correctly for locking the articulation.

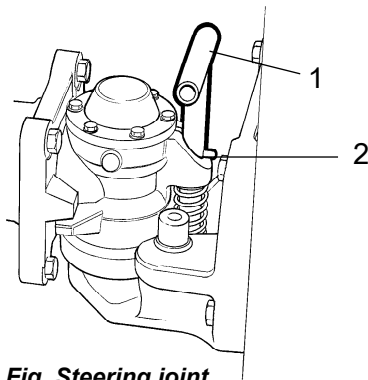



Fig. Steering joint
1. Locking arm
2. Cotter pin in locked position

Lifting the roller

 **The machine's gross weight is specified on the hoisting plate (1). Refer also to the Technical specifications.**

 Lifting gear such as chains, steel wires, straps, and lifting hooks must be dimensioned and used in accordance with the applicable safety regulations for lifting devices.

 **Stand well clear of the hoisted machine! Make sure that the lifting hooks are properly secured.**

Weight: refer to the hoisting plate on the roller

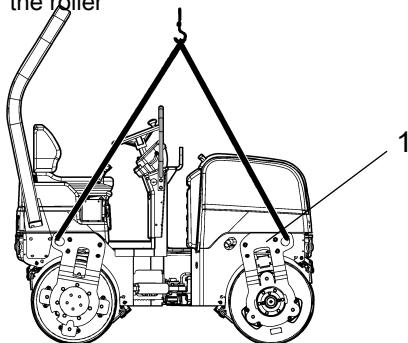

Fig. Roller prepared for lifting
1. Hoisting plate

Unlocking the articulation

 Remember to unlock the articulation before operating.

Raise the locking arm (1) and turn it 180 degrees upward. Check that the cotter pin (2) is guided correctly into position for unlocking the articulation.

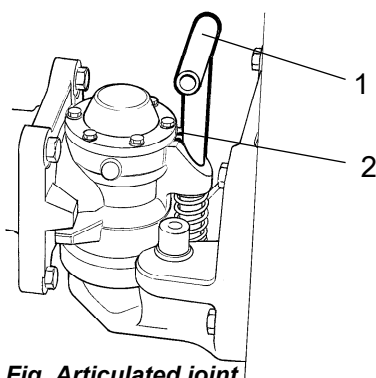
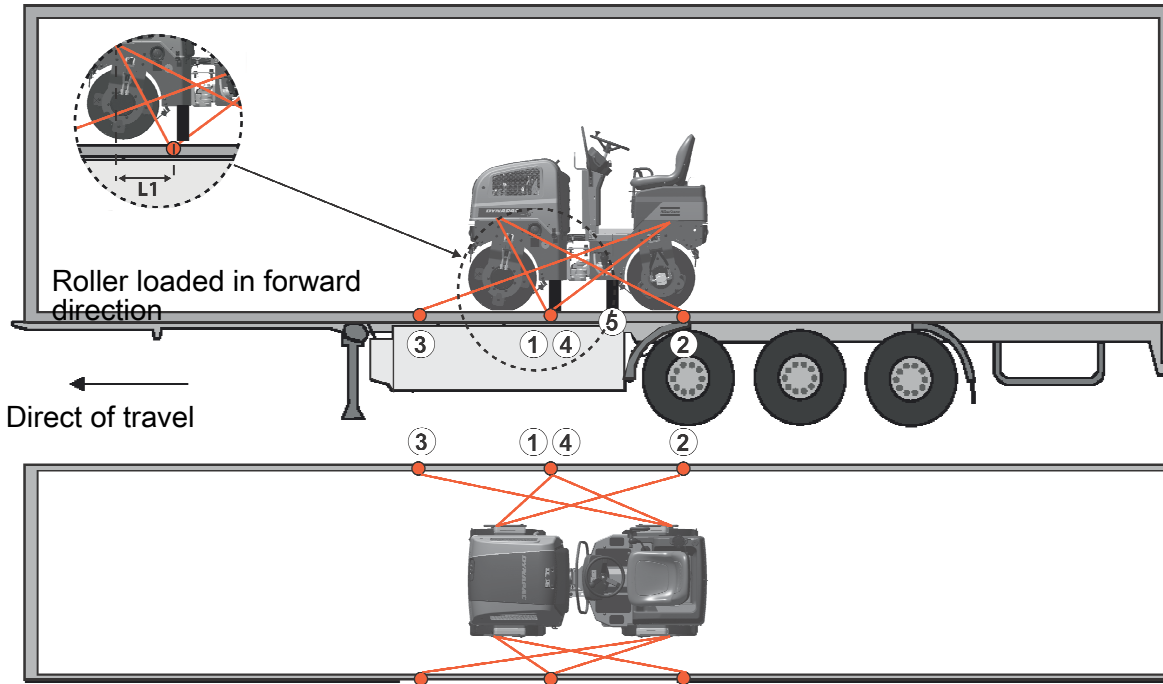

Fig. Articulated joint
1. Locking arm
2. Cotter pin in open position

Securing CC900G for loading

Securing the CC900G vibratory roller from Dynapac for transport.



- 1 - 2 = double lashings, i.e. one lashing with two parts secured to two different lashing mounts,
- 3 - 4 symmetrically located on the right and left sides.
- 5 = rubber

The lashings' permitted distance interval in meters		
(1 - 4: Double lashings, LC at least 1.7 tonnes (1700 daN), S _{TF} 300 kg (300daN))		
Double L ₁ - L ₂	Double L ₃ - L ₄	
0,6 - 3,0	0,1 - 3,0	

The distance L₁ above is between points D and E. D is the projected point directly at right angles laterally in relation to the edge of the platform from the lashing mount C on the roller. E is the lashing mount at the edge of the platform. L₂ - L₃ have a corresponding relationship.

Load carrier

- When loaded, the vibratory roller is centered laterally on the platform (± 5 cm).
- The parking brake is applied and in good working condition, and the articulated joint lock is closed.
- The drum is placed on a rubber liner, so that the static friction between the surfaces is at least 0.6.
- The contact surfaces must be clean, wet or dry, and free from frost, ice and snow.
- The lashing mounts on the load carrier have LC/MSL at least 2 tonnes.

Lashings

- The lashings comprise a lashing strap or chain with a permitted load (LC/MSL) of at least 1.7 tonnes (1,700 daN) and a pre-tension S_{TF} of at least 300 kg (300 daN). The lashings are re-tightened as required.
- Each of lashings 1-3 is either a double or two single lashings. A double lashing runs in a sling through a lashing point or around a machine part and down into two different mounts on the platform.
- Lashings in the same direction are placed in different lashing mounts on the trailer. Lashings that are pulled in opposite directions may be placed in the same lashing mount, however.
- The lashings are as short as possible.
- The lashing hooks must not lose grip if the lashings become slack.
- The lashings are protected against sharp edges and corners.
- The lashings are located symmetrically in pairs on the right and left sides.

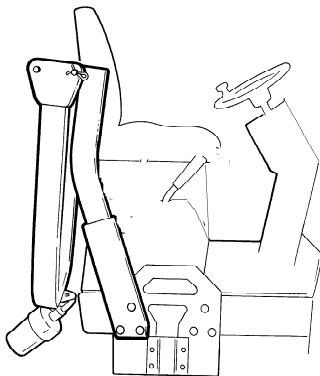

Fig. Retractable ROPS

Retractable ROPS (Optional)

The machine can be equipped with retractable ROPS.



Risk of crush injury when raising and lowering ROPS.



If the roller is equipped with a retractable ROPS, the machine must only be operated when it is lifted up and locked.

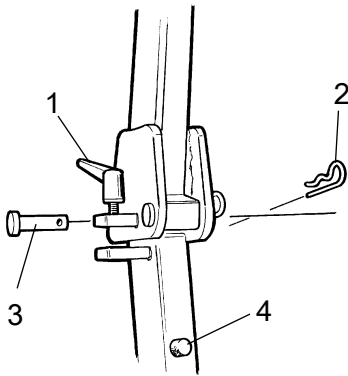

Fig. ROPS locking device
 1. Tensioning screw
 2. Pin
 3. Stud
 4. Rubber buffer

To retract the ROPS, release the tensioning screw (1), and pull out the pin (2) and stud (3). Do the same on both sides. Lower the ROPS backwards if there is space.



Remember to dismantle the rotating warning light before lowering the ROPS.



After lowering the ROPS, replace the pin and stud.

To lift the ROPS proceed in the reverse order.



Always make sure the ROPS is locked in raised position before operation.

Grease the tensioning screw (1) and stud (3) periodically.

Towing

The roller can be moved up to 300 meters (1,000 ft) using the instructions below.

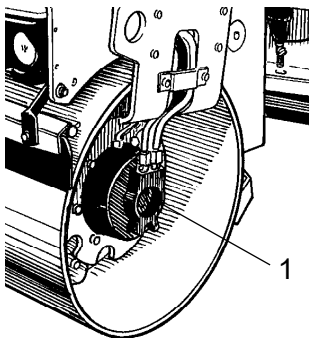

Fig. Drum
 1. Propulsion motor, located left front and right rear.



Switch off the gasoline engine and push in the emergency stop knob. Chock the drum to prevent the roller from moving when the brakes are disengaged.



The brakes in each propulsion motor must be mechanically released, as described below, before the roller is towed.

Releasing the brake

1. Remove the 2 plugs (191).

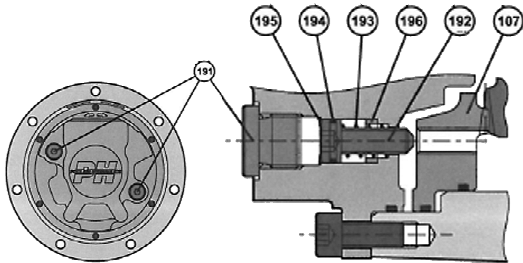
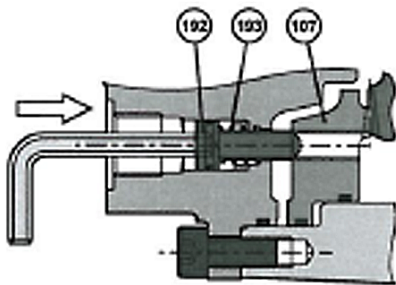

Figure. Releasing the brake



2. Press the screws (192) inwards to compress the springs (193) so that the screw reaches the brake (107) inner thread.

3. Tighten the two screws (192) alternately a little at a time so that the brake piston (107) loose (screw approximately 2 turns).



Tightening the screws (192) too hard can damage the inner mechanism



The machine should be started with reactivated brake.

Restored brake

Undo the two screws (192) alternately, and then insert the plugs (191).

Tightening torque

Screws (192)

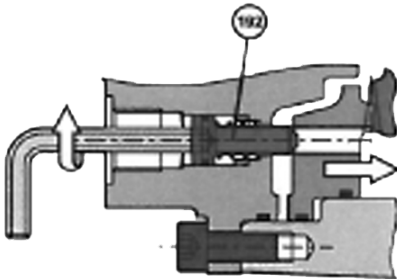
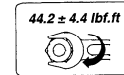

Plugs (191)

Towing the roller

A towing bar must be used when towing, as the roller has no brakes and can only be slowed and stopped by the vehicle towing the roller.



The roller must be towed slowly, max. 3 km/h (2 mph) and for short distances only, max. 300 m (1000 ft).

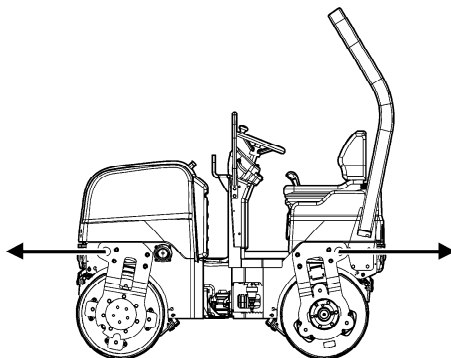

Fig. Towing the roller

When towing/recovering a machine, the towing device must be connected to both lifting holes. Pulling forces shall act longitudinally on the machine as illustrated. Max total towing force 50.8 kN (11,430 lbf), 25.4 kN (5,715 lbf) per fork.



Reset the steps taken for towing as described in the towing instructions on the previous page.

Operating instructions - Summary



1. Follow the **SAFETY INSTRUCTIONS** specified in the **Safety Manual**.
2. Make sure that all instructions in the **MAINTENANCE** section are followed.
3. Set the Emergency stop to its pulled-out position.
4. Move the forward/reverse lever to the **NEUTRAL** position.
5. Set the engine speed control to idle.
6. Start the engine and allow it to warm up.
7. Set the engine speed control to the operating position and make sure that the parking brake is deactivated.



8. **Drive the roller. Operate the forward/reverse lever with care.**



9. **Test the brakes. Remember that the braking distance will be longer if the roller is cold.**

10. Use vibration only when the roller is in motion.
11. Check that the drums are thoroughly watered when watering is required.



12. **IN AN EMERGENCY:**
 - Press the **EMERGENCY STOP**
 - Hold the steering wheel firmly.
 - Brace yourself for a sudden stop.
13. Parking: - Switch off the machine and chock the drums.
14. When lifting: - Refer to the relevant section in the Instruction Manual.
15. When towing: - Refer to the relevant section in the Instruction Manual.
16. When transporting: - Refer to the relevant section in the Instruction Manual.
17. When recovering - Refer to the relevant section in the Instruction Manual.

Preventive maintenance

Complete maintenance is necessary for the machine to function satisfactorily and at the lowest possible cost.

The Maintenance section includes the periodic maintenance that must be carried out on the machine.

The recommended maintenance intervals assume that the machine is used in a normal environment and working conditions.

Acceptance and delivery inspection

The machine is tested and adjusted before it leaves the factory.

On arrival, before delivery to the customer, delivery inspection must be conducted as per the check list in the warranty document.

Any transport damage must be reported immediately to the transport company, as this is not covered by the product warranty.

Warranty

The warranty is only valid if the stipulated delivery inspection and the separate service inspection have been completed as per the warranty document, and when the machine has been registered for starting under the warranty.

The warranty is not valid if damage has been caused by inadequate service, incorrect use of the machine, the use of lubricants and hydraulic fluids other than those specified in the manual, or if any other adjustments have been made without the requisite authorisation.

CALIFORNIA

Proposition 65

Decal and location of decal shown in section
Machine description.

 **WARNING:** Operating, servicing and maintaining a passenger vehicle or off-road vehicle can expose you to chemicals including engine exhaust, carbon monoxide, phthalates, and lead, which are known to the State of California to cause cancer and birth defects or other reproductive harm. To minimize exposure, avoid breathing exhaust, do not idle the engine except as necessary, service your vehicle in a well-ventilated area and wear gloves or wash your hands frequently when servicing your vehicle. For more information go to www.P65Warnings.ca.gov/passenger-vehicle.

Maintenance - Lubricants and symbols









Always use high-quality lubricants and the amounts recommended. Too much grease or oil can cause overheating, resulting in rapid wear.















Other fuel and lubricants are required when operating in areas with extremely high or extremely low ambient temperatures. See the 'Special instructions' chapter, or consult Dynapac.

Fluid volumes

Drum	3,5 liters	3,7 qts
Hydraulic reservoir	12 liters	3,2 gal
Gasoline engine	1,5 liters without filter replacement	1,6 qts
	1,8 liters with filter replacement	1,9 qts

	ENGINE OIL	Air temperature -15°C - +50°C (5°F-122°F)	Dynapac Engine 200	P/N 4812161855 (5 liters) P/N 4812161856 (20 liters)
	HYDRAULIC FLUID	Air temperature -15°C - +40°C (5°F-104°F)	Dynapac Hydraulic 300	P/N 4812161868 (20 liters) P/N 4812161869 (209 liters)
		Air temperature over +40°C (104°F)	Shell Tellus S2 V100	
	BIOLOGICAL HYDRAULIC FLUID, PANOLIN	When it leaves the factory, the machine may be filled with biologically degradable fluid. The same type of fluid must be used when changing or topping up.	PANOLIN HLP Synth 46 (www.panolin.com)	
	BIOLOGICAL HYDRAULIC FLUID	When it leaves the factory, the machine may be filled with biologically degradable fluid. The same type of fluid must be used when changing or topping up.	BP Biohyd SE-S46	
	DRUM OIL	Air temp. -15°C - +40°C (5°F-104°F)	Dynapac Gear oil 300	P/N 4812161883 (5 liters), P/N 4812161884 (20 liters)
		Air temp. 0°C (32°F) - above +40°C (104°F)	Shell Spirax AX 85W/140, API GL-5	
	FUEL	See engine manual. To comply with emission requirements for Honda GX630 you must use fuel with a low or extremely low sulphur content.	-	
	COOLANT	Anti-freeze protection down to about -37°C (-34.6°F)	Dynapac coolant 100 (mixed 50/50 with water)	P/N 4812161854 (20 liters)

Maintenance symbols

	Engine, oil level		Air filter
	Engine, oil filter		Battery
	Hydraulic reservoir, level		Sprinkler
	Hydraulic fluid, filter		Sprinkler water
	Drum, oil level		Recycling
	Lubricating oil		Fuel filter

Maintenance - Maintenance schedule

Service and maintenance points

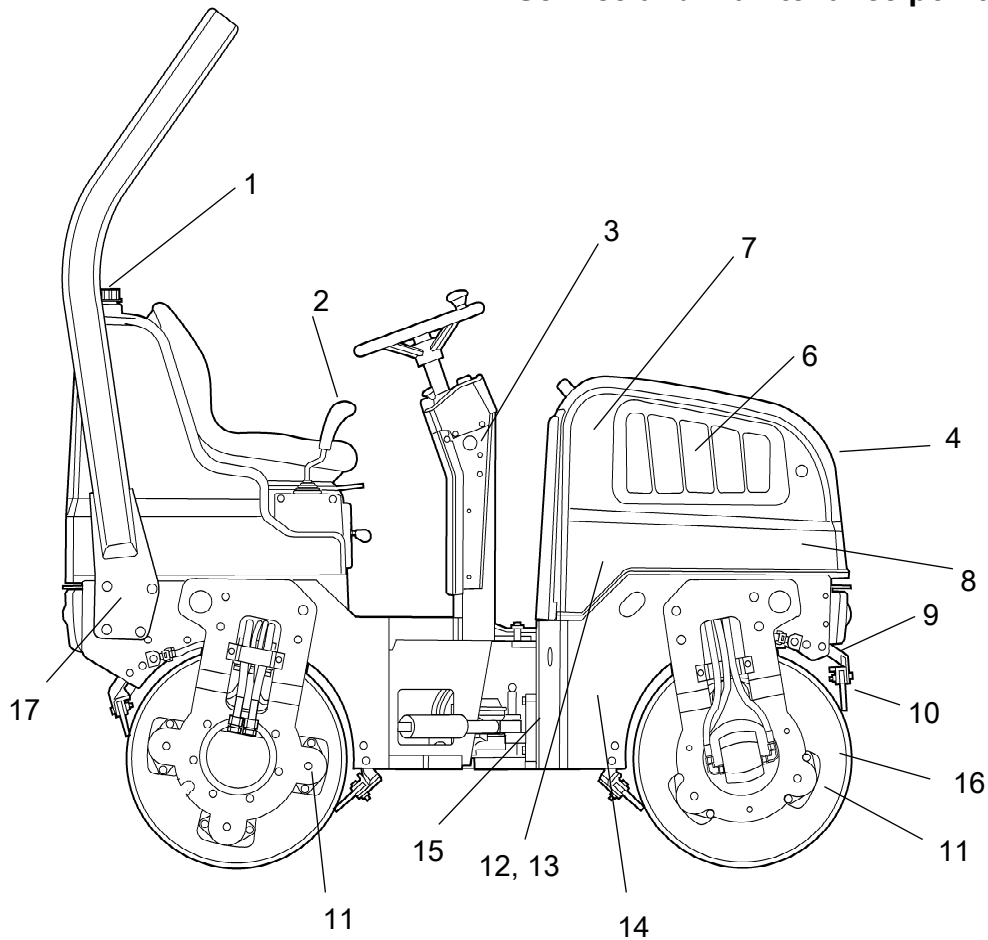

Fig. Service and maintenance points

- | | | |
|-------------------------------------|-------------------------------|----------------------------------|
| 1. Water tank, filling | 7. Air cleaner | 13. Hydraulic fluid, filling |
| 2. Forward/Reverse lever | 8. Battery (maintenance free) | 14. Fuel tank, filling |
| 3. Reserve/parking brake | 9. Sprinkler | 15. Steering joint |
| 4. Hydraulic fluid cooler, (option) | 10. Scrapers | 16. Front drum, filling with oil |
| 6. Engine | 11. Rubber element | 17. ROPS, (option) |
| | 12. Hydraulic fluid filter | |

General

Periodic maintenance should be carried out after the number of hours specified. Use the daily, weekly etc. periods where number of hours cannot be used.



Remove all dirt before filling, when checking oils and fuel and when lubricating using oil or grease.



The manufacturer's instructions found in the engine manual also apply.

Specific maintenance and checks on gasoline engines must be carried out by the engine supplier's certified personnel.



Where both operational hours and time intervals are specified, maintenance should be carried out at the point in time that occurs first.

Every 10 hours of operation (Daily)

Refer to the contents to find the page number of the sections referred to !

Pos. in fig	Action	Comment
	Before starting up for the first time on that day	
6	Check the oil level in the engine	Refer to the engine manual
13	Check the hydraulic reservoir level	
14	Refuel	
1	Fill the water tank	
9	Check the sprinkler system	
4	Check for free circulation of cooling air	
10	Check the scraper setting	
	Check the warning lamps	
7	Check the engine's air cleaner	Refer to the engine manual

After the first 20 hours of operation

Refer to the contents to find the page number of the sections referred to !

Pos. in fig	Action	Comment
6	Change the engine oil	Refer to the engine manual
6	Change the engine's oil filter	Refer to the engine manual

After the FIRST 50 hours of operation

Refer to the contents to find the page number of the sections referred to !

	Action	Comment
12	Change the hydraulic fluid filter	

Every 50 hours of operation

Refer to the contents to find the page number of the sections referred to !

Pos. in fig	Action	Comment
3	Test the brakes	
7	Clean the air cleaner	Refer to the engine manual
11	Check the rubber elements and bolted joints	

Every 100 hours of operation

Refer to the contents to find the page number of the sections referred to !

Pos. in fig	Action	Comment
6	Check and adjust the spark plug	Refer to the engine manual

Maintenance - Maintenance schedule

Every 200 / 400 / 600 / 800 hours of operation

Refer to the contents to find the page number of the sections referred to !

Pos. in fig	Action	Comment
6	Replace the spark plugs	Refer to the engine manual.
6	Check idling revs	Refer to the engine manual.
6	Check valve play	Refer to the engine manual.
6	Replace the fuel filter	Refer to the engine manual.
4	Clean the hydraulic fluid cooler	Accessory
6	Change the engine oil	Refer to the engine manual.
6	Change the oil filter	Refer to the engine manual.
	Check lubrication of controls and pivots	Lubricate as necessary
	Replace valve cover gasket	Refer to the engine manual.

Every 500 hours of operation

Refer to the contents to find the page number of the sections referred to !

Pos. in fig	Action	Comment
6	Clean the combustion chamber	Refer to the engine manual
16	Check the oil level in the front drum	
13	Check the hydraulic reservoir cover/breather	
15	Check the condition of the articulation	
7	Replace the air cleaner insert	Refer to the engine manual

Every 1000 hours of operation

Refer to the contents to find the page number of the sections referred to !

Pos. in fig	Action	Comment
6	Replace the spark plugs	Refer to the engine manual.
6	Check idling revs	Refer to the engine manual.
6	Check valve play	Refer to the engine manual.
6	Replace the fuel filter	Refer to the engine manual.
4	Clean the hydraulic fluid cooler	Accessory
	Check lubrication of controls and pivots	Lubricate as necessary
	Replace valve cover gasket	Refer to the engine manual.
6	Clean the combustion chamber	Refer to the engine manual.
16	Check the oil level in the front drum	
13	Check the hydraulic reservoir cover/breather	
15	Check the condition of the articulation	
7	Replace the air cleaner insert	Refer to the engine manual.
12	Change the hydraulic fluid filter	
6	Change the engine oil	Refer to the engine manual.
6	Change the oil filter	Refer to the engine manual.

Every 2000 hours of operation

Refer to the contents to find the page number of the sections referred to !

Pos. in fig	Action	Comment
6	Replace the spark plugs	Refer to the engine manual
6	Check idling revs	Refer to the engine manual
6	Check valve play	Refer to the engine manual
6	Replace the fuel filter	Refer to the engine manual
4	Clean the hydraulic fluid cooler	Accessory
	Check lubrication of controls and pivots	Lubricate as necessary
	Replace valve cover gasket	Refer to the engine manual
6	Clean the combustion chamber	Refer to the engine manual
13	Check the hydraulic reservoir cover/breather	
15	Check the condition of the articulation	
7	Replace the air cleaner insert	Refer to the engine manual
12	Change the hydraulic fluid filter	
6	Change the engine oil	Refer to the engine manual
6	Change the oil filter	Refer to the engine manual
13	Change the hydraulic fluid	
16	Change the oil in the front drum	
1	Drain and clean the water tank	
6	Drain and clean the fuel tank	Refer to the engine manual
6	Check the fuel line	Refer to the engine manual

Maintenance, 10h

Every 10 hours of operation (Daily)



**Park the roller on a level surface.
The engine must be switched off and the parking brake activated when checking or adjusting the roller, unless otherwise specified.**

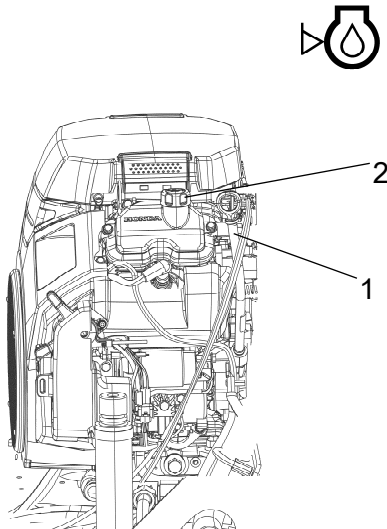

Fig. Engine
1. Dipstick
2. Filler plug

Engine - Checking the oil level



Ensure that the engine cover is fully open when work is carried out under the cover.

Open the engine cover lock and lower the engine cover forwards.

Check the oil level using the dipstick (1). The level should be between the marks. If the level is near the lower mark, top off with fresh engine oil via the filler cap (2). See under the heading lubricants for the correct oil grade.



Never overfill with oil, as this can damage the engine.



Hydraulic reservoir, Level check - Filling

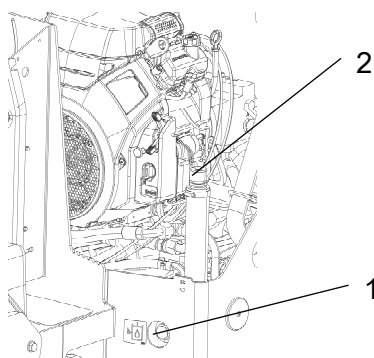

Fig. Hydraulic reservoir
1. Sight glass
2. Filler hose

Wipe the sight glass (1) clean. Make sure that the oil level is in the middle of the sight glass. If necessary, top up with fresh hydraulic fluid through the filler hose (2).

See under the heading 'Lubricants' for the correct fluid grade.



Refueling

Refuel the tank every day before starting work. Open the tank cap and fill through the filler pipe (1).



Never refuel while the engine is running. Do not smoke and avoid spilling fuel.



Stop the engine. Short-circuit (press) the filler gun against the filler pipe (1) while refuelling.

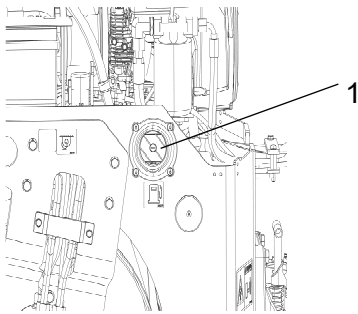

Fig. Left side
1. Filler pipe/cap

The tank holds 23 liters (31.7 gal) of fuel.



Water tank - Filling



Unscrew the tank cap (1), and fill with clean water.

Fill the water tank; it holds 175 liters.



Only additive: A small amount of environmentally friendly antifreeze.

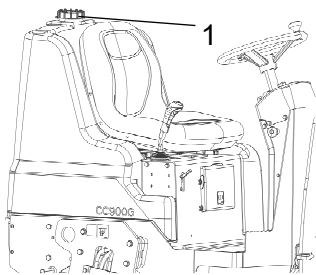

Fig. Water tank
1. Tank cap



Sprinkler system - Check, cleaning

Check that the holes in the sprinkler pipe (1) are not clogged, clean if necessary.

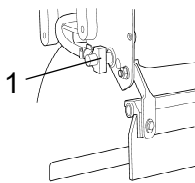

Fig. Sprinkler system
1. Sprinkler pipes with holes for water.

Air circulation - Check

Ensure that the gasoline engine has free circulation of cooling air through the vents in the hood.

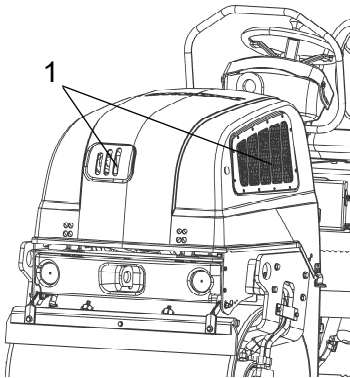

Fig. Engine cover
1. Cooling air grille/engine

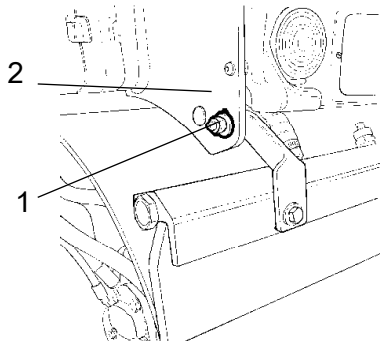

Fig. Front scrapers in transport position
1. Locking nut
2. Frame side

Scrapers - Check, adjustment

Make sure that the scrapers are undamaged. Adjust the scrapers if necessary in the following way:

For firmer application of the scraper, undo the locking nut (2) and turn it to the right until the desired application is achieved.

Lock this setting by tightening the locking nut against the frame side (2).

Adjust the pressure on both scraper brackets.

To set a lower scraper pressure, adjust in the reverse order to the above.

Warning lamps - Check

Check that the warning lamp on the control panel is functional (12).



Fig. Control panel
3. Parking brake
12. Parking brake warning lamp



Air cleaner - check

Check that hoses and couplings are not leaking and that the air cleaner cover is on properly.

Clean the air cleaner when operated in extremely dusty environments.

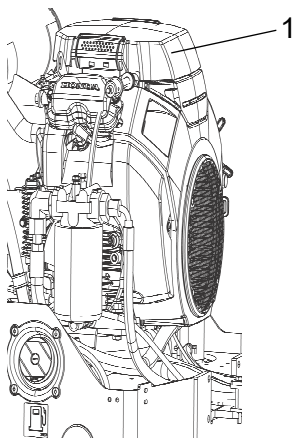



Fig. Engine
1. Air filter

Maintenance - 20h

 **Park the roller on a level surface. The engine must be switched off and the parking brake activated when checking or adjusting the roller, unless otherwise specified.**

 **Check that the engine cover is fully open before carrying out work underneath it.**



Engine oil and oil filter - Change

Run the engine until it is warm before draining the oil.

 **Switch off the engine and push in the reserve/parking brake knob.**

 **Take great care when draining fluids and oils. Wear protective gloves and goggles.**

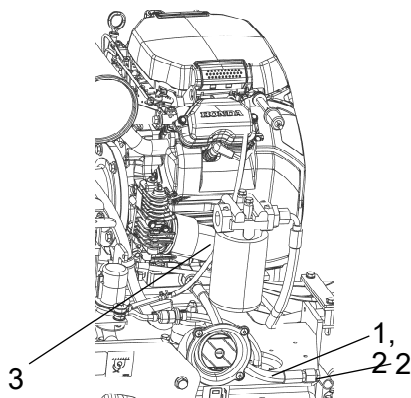

Fig. Engine compartment, left side

- 1. Drain hose
- 2. Plug
- 3. Oil filter

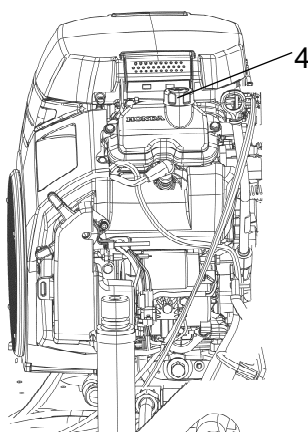



Fig. Engine compartment, right side
4. Filler cap

Place a receptacle that holds at least 4 liters (1 gal.) under the drain plug (2).

Undo the oil filler cap (4) and remove the plug (2) from the end of the drain hose (1); allow all the engine oil to run out.

 **Deliver the drained oil to special waste handling.**

 **Refer to the engine manual for detailed instructions when changing oil and filters.**

Remove the oil filter (3) and insert a new one.

Collect any spillage.

Fit the drain plug (2) to the end of the hose.

Fill with fresh engine oil (see under Lubricants heading for the correct oil grade), refit the filler cap (4) and check the level on the dipstick.

Start the engine and check the tightness around the oil filter.

Maintenance - 50h

Every 50 hours of operation (Weekly)

 **Park the roller on a level surface. The engine must be switched off and the parking brake activated when checking or adjusting the roller, unless otherwise specified.**

 **Check that the engine cover is fully open before carrying out work underneath it.**



Brakes - Check

 **Check the brakes by carrying out the following:**

Drive the roller slowly forwards.

Activate the parking brake (3). The brake warning lamp (12) should light and the roller should stop.

After testing the brakes, set the forward/reverse lever in neutral.

Deactivate the parking brake (3).

The roller can now be started.

Refer also to the section for operation.



Figure. Instrument panel
3. Parking brake
12. Brake warning lamp

Air cleaner - cleaning

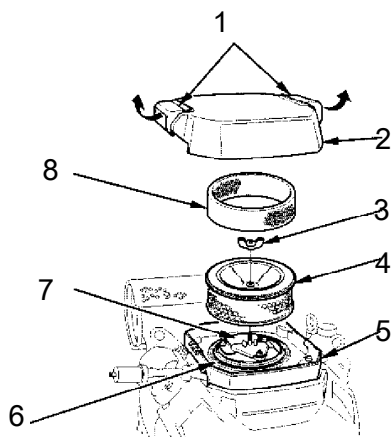

Fig. Air cleaner

1. Cover latch
2. Cover
3. Wing nut
4. Filter element
5. Case
6. Seal
7. Air chamber
8. Foam filter element

Unclip the four lock catches (1) and lift the air cleaner's cover (2). Lift out the plastic foam and clean it in warm soapy water, rinse and dry.

Clean the air filter by tapping it with the palm of the hand or blow compressed air (not exceeding 207 kPa (2,1 kgf/cm², 30 psi)) through the filter element from the air cleaner case side. Brushing the filter may cause dust to penetrate the fibres. Replace the filter if it is very dirty.

Dry the inside of the filter container and its cover with a damp rag. Make sure that dirt does not enter the suction pipe.

Clean the air cleaner when operated in extremely dusty environments.

Refit the filter element and the cover and secure the cover with put the latch (1) to locked position.

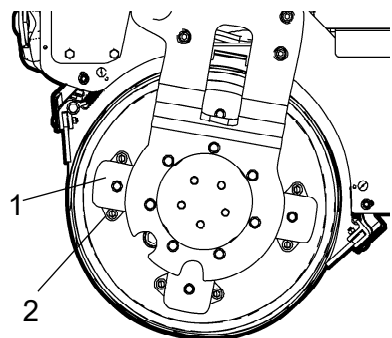

Figure. Drum suspension

1. Rubber element
2. Fastening screws

Rubber elements and fastening screws - Check

Check all the rubber elements (1), and replace all the elements if more than 20% of them on one side of the drum are cracked deeper than 10-15 mm.

Use a the blade of a knife or pointed object to check.

Check also that the screw fasteners (2) are tightened.



The screws on the rubber elements are sealed with Loctite. Check the rubber elements on both sides of the roller.

Maintenance - 100h



***Park the roller on a level surface.
The engine must be switched off and the
parking brake activated when checking or
adjusting the roller, unless otherwise specified.***



***Check that the engine cover is fully open before
carrying out work underneath it.***

Spark plug - Check and adjustment



***Switch off the engine and push in the
reserve/parking brake knob.***



Observe care with hot surfaces. Wear gloves.

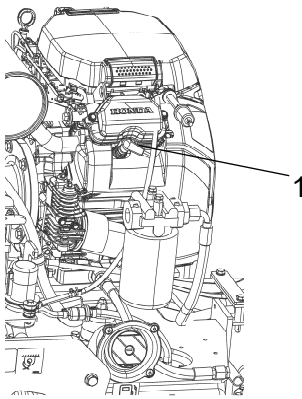

**Fig. Engine compartment left side
1. Spark plug**



**Refer to the engine manual for detailed
instructions.**



Dispose of used spark plugs properly.

Maintenance - 200 / 400 / 600 / 800 h



**Park the roller on a level surface.
The engine must be switched off and the
parking brake activated when checking or
adjusting the roller, unless otherwise specified.**



**Check that the engine cover is fully open before
carrying out work underneath it.**



Spark plug - Replace



**Switch off the engine and push in the
reserve/parking brake knob.**



Observe care with hot surfaces. Wear gloves.



**Refer to the engine manual for detailed
instructions.**

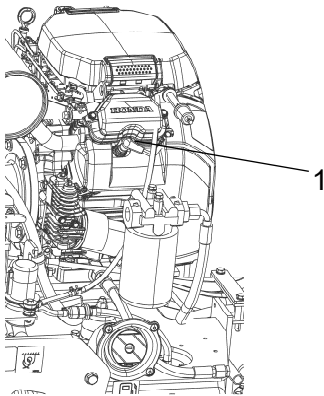

**Fig. Engine compartment left side
1. Location of the spark plug on the
left and right sides of the engine.**



Dispose of used spark plugs properly.



Engine's fuel filter - Check



Switch off the engine and push in the reserve/parking brake knob.



Use caution. Wear gloves.

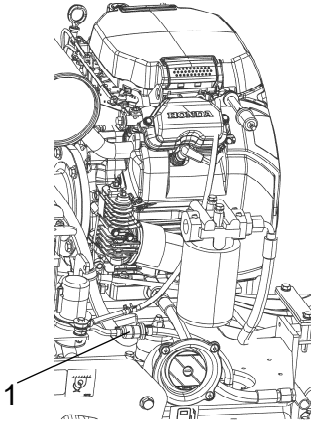

**Fig. Engine compartment left side
1. Fuel filter**

Replace the fuel filter (1).



Refer to the engine manual for detailed instructions.



Dispose of the old filter carefully.

Hydraulic fluid cooler - Cleaning (Option)

Clean the hydraulic fluid cooler's cooling flanges, ideally with compressed air. Blow the cooler clean by blowing air from the inside outwards.



Wear gloves and eye protectors when working with compressed air.



Engine oil and oil filter - Change

Run the engine until it is warm before draining the oil.



Switch off the engine and push in the reserve/parking brake knob.



Take great care when draining fluids and oils. Wear protective gloves and goggles.

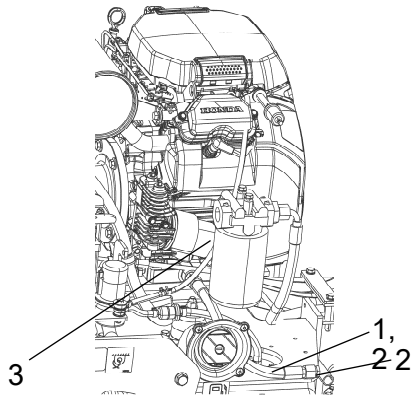

Fig. Engine compartment, left side

- 1. Drain hose
- 2. Plug
- 3. Oil filter

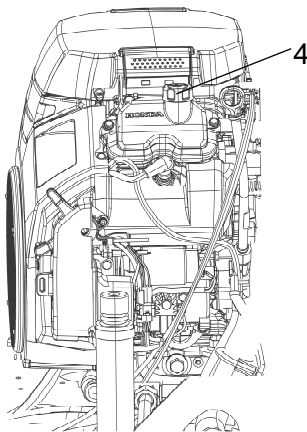

Fig. Engine compartment, right side
4. Filler cap

Place a receptacle that holds at least 4 liters (1 gal.) under the drain plug (2).

Undo the oil filler cap (4) and remove the plug (2) from the end of the drain hose (1); allow all the engine oil to run out.



Deliver the drained oil to special waste handling.



Refer to the engine manual for detailed instructions when changing oil and filters.

Remove the oil filter (3) and insert a new one.

Collect any spillage.

Fit the drain plug (2) to the end of the hose.

Fill with fresh engine oil (see under Lubricants heading for the correct oil grade), refit the filler cap (4) and check the level on the dipstick.

Start the engine and check the tightness around the oil filter.



Forward/Reverse controls and joints - Check and lubrication

Unscrew the protective plate. Check the friction on the forward/reverse lever. The friction nut (1) should be applied with sufficient pressure to keep the forward/reverse lever in the set position during operation.

If the lever gets stiff after prolonged use, lubricate the lever at the bearing bushings and at the cable with a few drops of oil at each place.

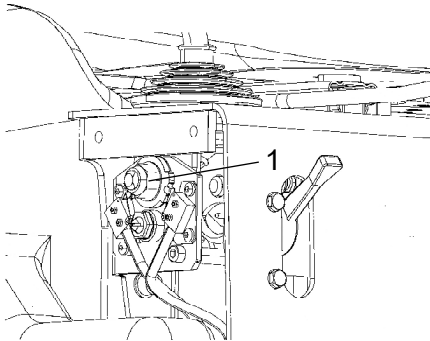

Figure. Forward/reverse lever
1. Friction nut

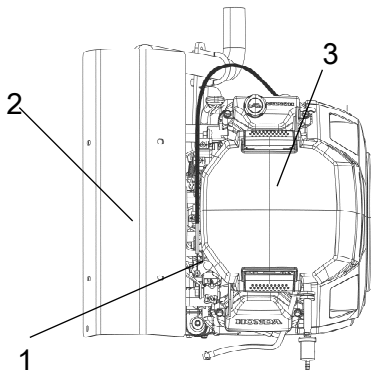



Fig. Engine compartment
1. F/R lever cable
2. Heat cover
3. Air filter

If the forward/reverse lever still is stiff after the above adjustments, lubricate the other end of the control cable with a few drops of oil. The cable is located on the top of the propulsion pump.

Maintenance - 500h

 **Park the roller on a level surface. The engine must be switched off and the parking brake activated when checking or adjusting the roller, unless otherwise specified.**

 **Check that the engine cover is fully open before carrying out work underneath it.**



Front drum - Checking the oil level

Park the roller on a level surface, and drive the roller slowly until the oil plug (1) is in the middle of the semicircle shaped notch in the drum suspension.

 **Switch off the engine, disconnect the power and push in the reserve/parking brake knob.**

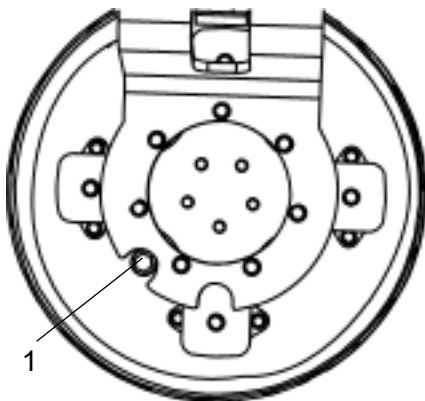

Figure. Front drum, drive side
1. Oil plug

Unscrew the plug and check that the oil level reaches the hole's lower edge. If necessary, top off with fresh transmission fluid. See under the heading lubricants for correct fluid grade.

Clean the magnetic oil plug (1) from any metallic residue, and refit the plug.



Hydraulic reservoir - Check/venting

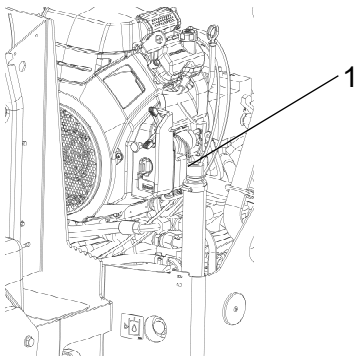

Figure. Engine compartment, right side
1. Hydraulic fluid tank cap

Unscrew and make sure that the reservoir cap is not blocked. Air must have unobstructed passage through the cap in both directions.

If blocked in either direction, clean with a little diesel oil and blow with compressed air until unblocked or replace the cap with a new one.



Wear eye protectors and gloves when working with compressed air.

Steering joint - Check

Inspect the steering joint to detect any damage or cracks.

Check and tighten any loose bolts.

Check also for any stiffness and play in the steering joint. Rectify if necessary.

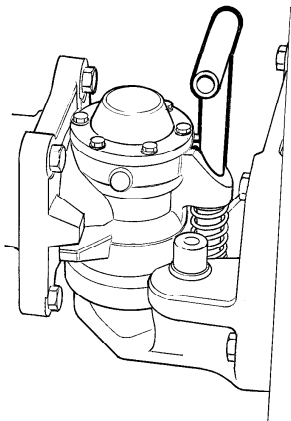

Fig. Steering joint

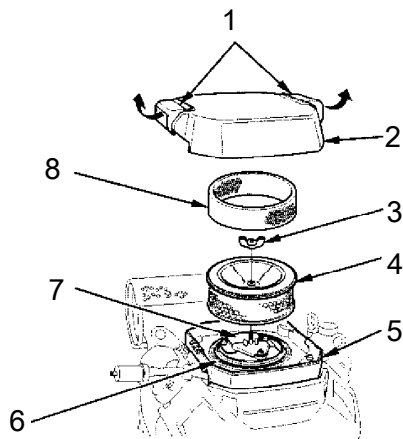

Fig. Air cleaner

- 1. Cover latch
- 2. Cover
- 3. Wing nut
- 4. Filter element
- 5. Case
- 6. Seal
- 7. Air chamber
- 8. Foam filter element

Air cleaner - replace insert

Pull the air cleaner cover latch (1) to the unlocked position and remove the cover (2).

Remove the wing nut (3) from the filter element (4).

Lift out the foam filter element (8) and the filter element (4).

Dry the inside of the filter container and its cover with a damp rag. Make sure that dirt does not enter the suction pipe.

Reinstall with new filter element and secure the cover with put the latch (1) to locked position.

Maintenance - 1000h

Performed after 1000 operating hours (each year)



***Park the roller on a level surface.
The engine must be switched off and the parking brake activated when checking or adjusting the roller, unless otherwise specified.***



Check that the engine cover is fully open before carrying out work underneath it.

**Spark plug - Replace**

Switch off the engine and push in the reserve/parking brake knob.



Observe care with hot surfaces. Wear gloves.



Refer to the engine manual for detailed instructions.

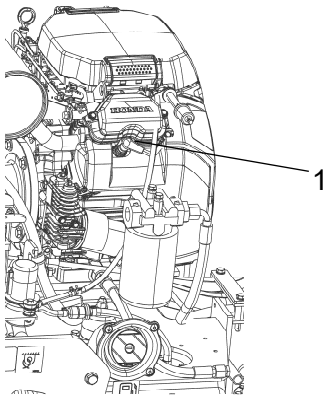

**Fig. Engine compartment left side
1. Location of the spark plug on the left and right sides of the engine.**



Dispose of used spark plugs properly.



Engine's fuel filter - Check



Switch off the engine and push in the reserve/parking brake knob.



Use caution. Wear gloves.

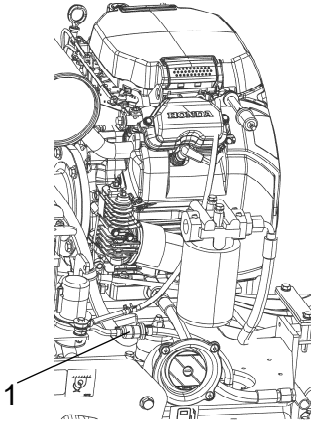

**Fig. Engine compartment left side
1. Fuel filter**

Replace the fuel filter (1).



Refer to the engine manual for detailed instructions.



Dispose of the old filter carefully.

Hydraulic fluid cooler - Cleaning (Option)

Clean the hydraulic fluid cooler's cooling flanges, ideally with compressed air. Blow the cooler clean by blowing air from the inside outwards.



Wear gloves and eye protectors when working with compressed air.



Forward/Reverse controls and joints - Check and lubrication

Unscrew the protective plate. Check the friction on the forward/reverse lever. The friction nut (1) should be applied with sufficient pressure to keep the forward/reverse lever in the set position during operation.

If the lever gets stiff after prolonged use, lubricate the lever at the bearing bushings and at the cable with a few drops of oil at each place.

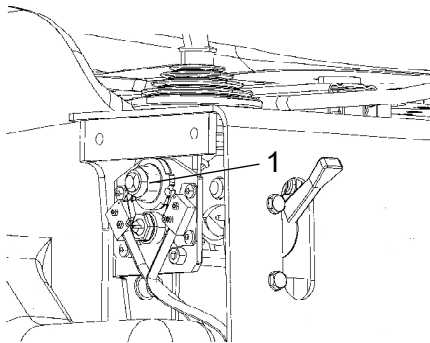

Figure. Forward/reverse lever
1. Friction nut

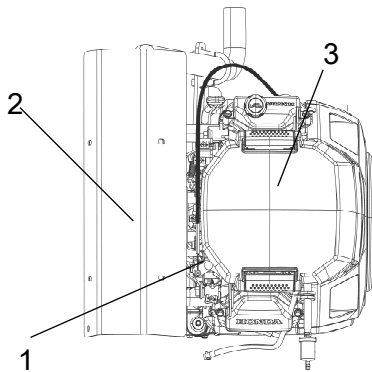

Fig. Engine compartment
1. F/R lever cable
2. Heat cover
3. Air filter

If the forward/reverse lever still is stiff after the above adjustments, lubricate the other end of the control cable with a few drops of oil. The cable is located on the top of the propulsion pump.



Front drum - Checking the oil level

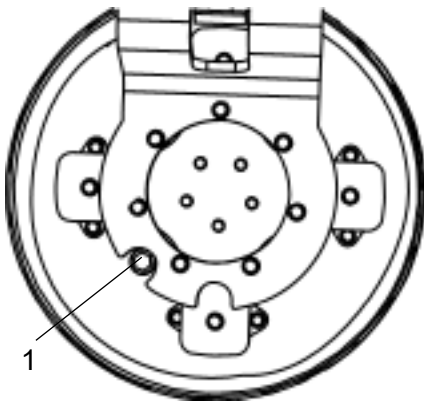

Figure. Front drum, drive side
1. Oil plug

Park the roller on a level surface, and drive the roller slowly until the oil plug (1) is in the middle of the semicircle shaped notch in the drum suspension.



Switch off the engine, disconnect the power and push in the reserve/parking brake knob.

Unscrew the plug and check that the oil level reaches the hole's lower edge. If necessary, top off with fresh transmission fluid. See under the heading lubricants for correct fluid grade.

Clean the magnetic oil plug (1) from any metallic residue, and refit the plug.



Hydraulic reservoir - Check/venting

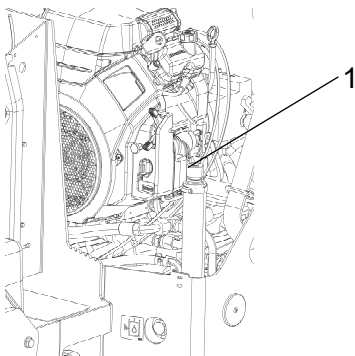

Figure. Engine compartment, right side
1. Hydraulic fluid tank cap

Unscrew and make sure that the reservoir cap is not blocked. Air must have unobstructed passage through the cap in both directions.

If blocked in either direction, clean with a little diesel oil and blow with compressed air until unblocked or replace the cap with a new one.



Wear eye protectors and gloves when working with compressed air.

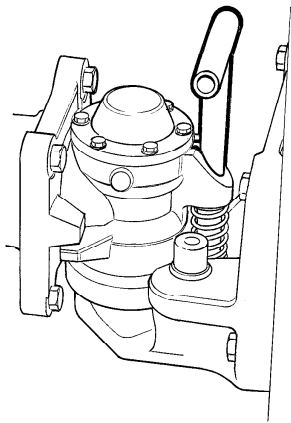

Fig. Steering joint

Steering joint - Check

Inspect the steering joint to detect any damage or cracks.

Check and tighten any loose bolts.

Check also for any stiffness and play in the steering joint. Rectify if necessary.

Air cleaner - replace insert

Pull the air cleaner cover latch (1) to the unlocked position and remove the cover (2).

Remove the wing nut (3) from the filter element (4).

Lift out the foam filter element (8) and the filter element (4).

Dry the inside of the filter container and its cover with a damp rag. Make sure that dirt does not enter the suction pipe.

Reinstall with new filter element and secure the cover with put the latch (1) to locked position.

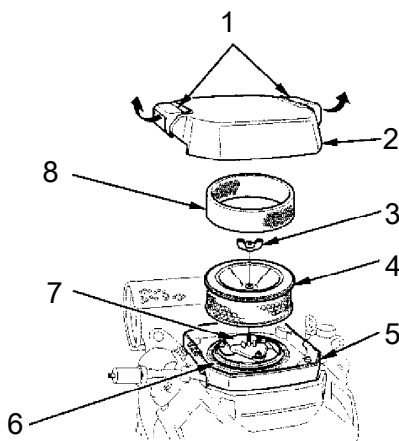

Fig. Air cleaner

1. Cover latch
2. Cover
3. Wing nut
4. Filter element
5. Case
6. Seal
7. Air chamber
8. Foam filter element



Hydraulic fluid filter - Change



Remove the filter (1) and deliver to special waste handling. This is a single-use filter and cannot be cleaned.

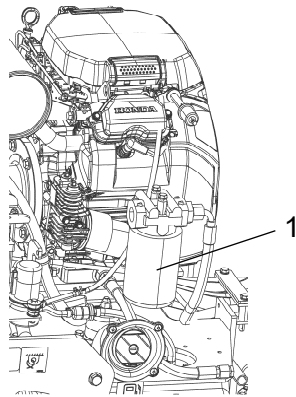

Fig. Engine compartment, left side
1. Hydraulic fluid filter

Thoroughly clean the filter holder sealing surface.

Apply a thin coat of fresh hydraulic fluid to the rubber gasket on the new filter.

Screw the filter on by hand, firstly until the filter gasket makes contact with the filter base. Then rotate a further $\frac{1}{2}$ turn.



Do not over-tighten. The seal can be damaged.

Start the engine and check that the filter does not leak.



Engine oil and oil filter - Change

Run the engine until it is warm before draining the oil.



Switch off the engine and push in the reserve/parking brake knob.



Take great care when draining fluids and oils. Wear protective gloves and goggles.

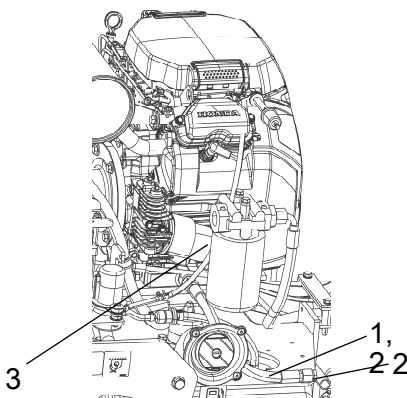

Fig. Engine compartment, left side
1. Drain hose
2. Plug
3. Oil filter

Place a receptacle that holds at least 4 liters (1 gal.) under the drain plug (2).

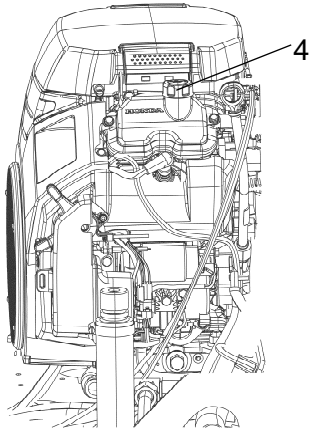

Fig. Engine compartment, right side
4. Filler cap

Undo the oil filler cap (4) and remove the plug (2) from the end of the drain hose (1); allow all the engine oil to run out.



Deliver the drained oil to special waste handling.



Refer to the engine manual for detailed instructions when changing oil and filters.

Remove the oil filter (3) and insert a new one.

Collect any spillage.

Fit the drain plug (2) to the end of the hose.

Fill with fresh engine oil (see under Lubricants heading for the correct oil grade), refit the filler cap (4) and check the level on the dipstick.

Start the engine and check the tightness around the oil filter.

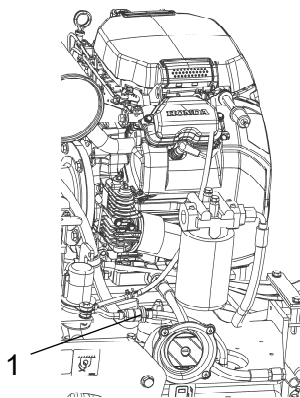

Fig. Engine compartment left side
1. Fuel filter

Engine's fuel filter - Check



Switch off the engine and push in the reserve/parking brake knob.



Use caution. Wear gloves.

If the fuel filter is full of water or deposits, replace the filter with a new one.



Refer to the engine manual for detailed instructions.



Dispose of the old filter carefully.

Maintenance - 2000h

Performed after 2000 operating hours (every two years)

 **Park the roller on a level surface. The engine must be switched off and the parking brake activated when checking or adjusting the roller, unless otherwise specified.**

 **Check that the engine cover is fully open before carrying out work underneath it.**



Spark plug - Replace

 **Switch off the engine and push in the reserve/parking brake knob.**

 **Observe care with hot surfaces. Wear gloves.**

 **Refer to the engine manual for detailed instructions.**

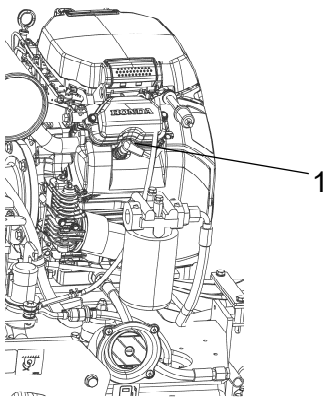



Fig. Engine compartment left side
1. Location of the spark plug on the left and right sides of the engine.

 **Dispose of used spark plugs properly.**



Engine's fuel filter - Check



Switch off the engine and push in the reserve/parking brake knob.



Use caution. Wear gloves.

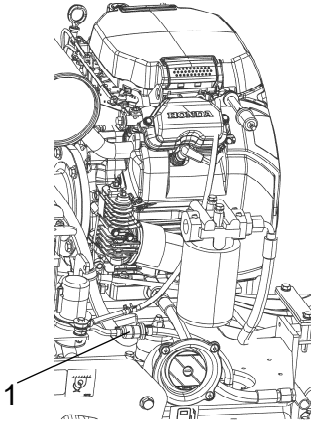

**Fig. Engine compartment left side
1. Fuel filter**

Replace the fuel filter (1).



Refer to the engine manual for detailed instructions.



Dispose of the old filter carefully.

Hydraulic fluid cooler - Cleaning (Option)

Clean the hydraulic fluid cooler's cooling flanges, ideally with compressed air. Blow the cooler clean by blowing air from the inside outwards.



Wear gloves and eye protectors when working with compressed air.



Forward/Reverse controls and joints - Check and lubrication

Unscrew the protective plate. Check the friction on the forward/reverse lever. The friction nut (1) should be applied with sufficient pressure to keep the forward/reverse lever in the set position during operation.

If the lever gets stiff after prolonged use, lubricate the lever at the bearing bushings and at the cable with a few drops of oil at each place.

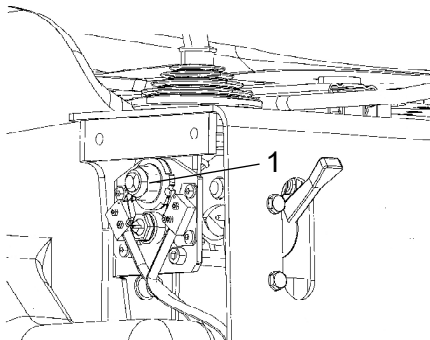

Figure. Forward/reverse lever
1. Friction nut

If the forward/reverse lever still is stiff after the above adjustments, lubricate the other end of the control cable with a few drops of oil. The cable is located on the top of the propulsion pump.

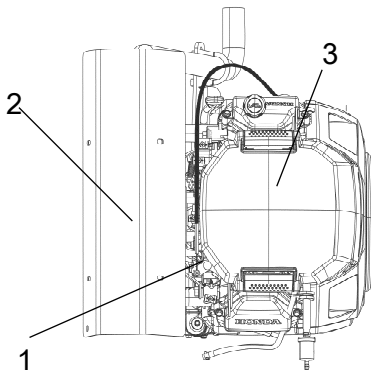

Fig. Engine compartment
1. F/R lever cable
2. Heat cover
3. Air filter



Hydraulic reservoir - Check/venting

Unscrew and make sure that the reservoir cap is not blocked. Air must have unobstructed passage through the cap in both directions.

If blocked in either direction, clean with a little diesel oil and blow with compressed air until unblocked or replace the cap with a new one.



Wear eye protectors and gloves when working with compressed air.

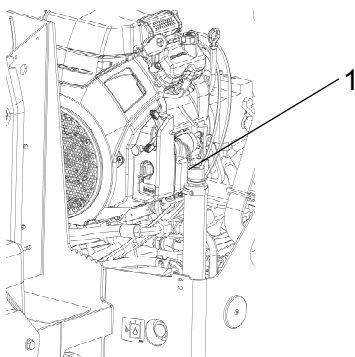

Figure. Engine compartment, right side
1. Hydraulic fluid tank cap

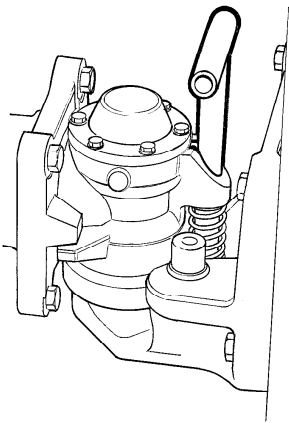

Fig. Steering joint

Steering joint - Check

Inspect the steering joint to detect any damage or cracks.

Check and tighten any loose bolts.

Check also for any stiffness and play in the steering joint. Rectify if necessary.

Air cleaner - replace insert

Pull the air cleaner cover latch (1) to the unlocked position and remove the cover (2).

Remove the wing nut (3) from the filter element (4).

Lift out the foam filter element (8) and the filter element (4).

Dry the inside of the filter container and its cover with a damp rag. Make sure that dirt does not enter the suction pipe.

Reinstall with new filter element and secure the cover with put the latch (1) to locked position.

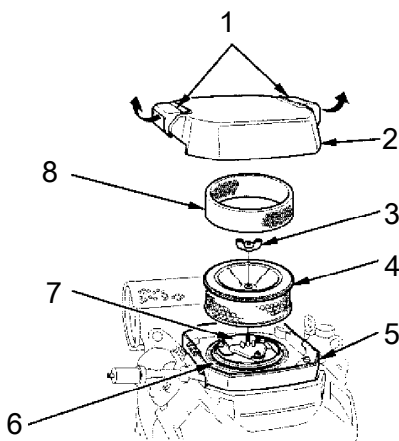

Fig. Air cleaner

1. Cover latch
2. Cover
3. Wing nut
4. Filter element
5. Case
6. Seal
7. Air chamber
8. Foam filter element



Hydraulic fluid filter - Change



Remove the filter (1) and deliver to special waste handling. This is a single-use filter and cannot be cleaned.

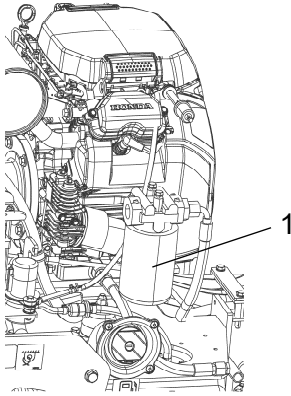

Fig. Engine compartment, left side
1. Hydraulic fluid filter

Thoroughly clean the filter holder sealing surface.

Apply a thin coat of fresh hydraulic fluid to the rubber gasket on the new filter.

Screw the filter on by hand, firstly until the filter gasket makes contact with the filter base. Then rotate a further $\frac{1}{2}$ turn.



Do not over-tighten. The seal can be damaged.

Start the engine and check that the filter does not leak.



Engine oil and oil filter - Change

Run the engine until it is warm before draining the oil.



Switch off the engine and push in the reserve/parking brake knob.



Take great care when draining fluids and oils. Wear protective gloves and goggles.

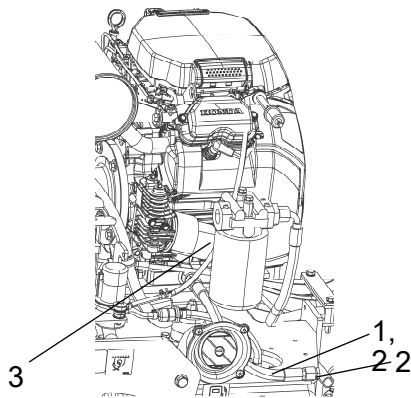

Fig. Engine compartment, left side
1. Drain hose
2. Plug
3. Oil filter

Place a receptacle that holds at least 4 liters (1 gal.) under the drain plug (2).

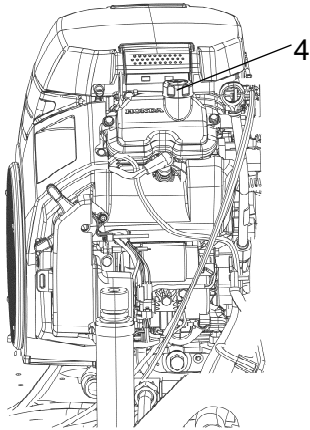

Fig. Engine compartment, right side
4. Filler cap

Undo the oil filler cap (4) and remove the plug (2) from the end of the drain hose (1); allow all the engine oil to run out.



Deliver the drained oil to special waste handling.



Refer to the engine manual for detailed instructions when changing oil and filters.

Remove the oil filter (3) and insert a new one.

Collect any spillage.

Fit the drain plug (2) to the end of the hose.

Fill with fresh engine oil (see under Lubricants heading for the correct oil grade), refit the filler cap (4) and check the level on the dipstick.

Start the engine and check the tightness around the oil filter.



Engine's fuel filter - Check



Switch off the engine and push in the reserve/parking brake knob.



Use caution. Wear gloves.

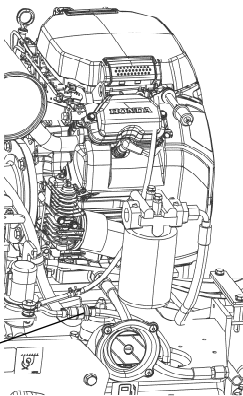

Fig. Engine compartment left side
1. Fuel filter

If the fuel filter is full of water or deposits, replace the filter with a new one.



Refer to the engine manual for detailed instructions.



Dispose of the old filter carefully.



Hydraulic reservoir - fluid change

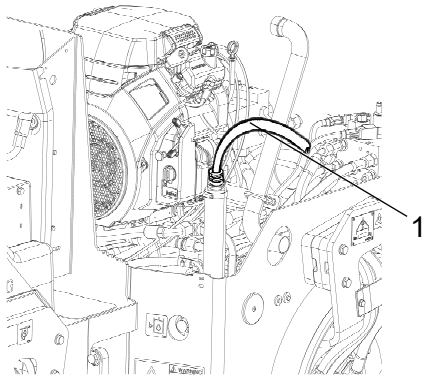

Fig. Hydraulic reservoir
1. Draining

Use an external drainage pump when draining/emptying the hydraulic reservoir.



Danger of being burned when draining hot oil.
Wear gloves and eye protectors.

Unscrew the reservoir cap. Use an external pump and check that the pump's hose reaches the bottom of the hydraulic reservoir in order to remove as much of the oil as possible. Drain the hydraulic oil into a drainage container.



Use a receptacle that holds at least 15 liters (4 gal).



Collect the oil and deliver to special waste handling.

Change the hydraulic fluid filter, see under heading 'Every 900 hours of operation'.

Fill with fresh hydraulic fluid (see under Lubricants heading for the correct grade), refit the filler cap, and check the level in the tank.

Wipe up any spillage.

Start the engine and operate the various hydraulic functions. Check the level in the reservoir and top off as required.



Front drum - Changing the oil

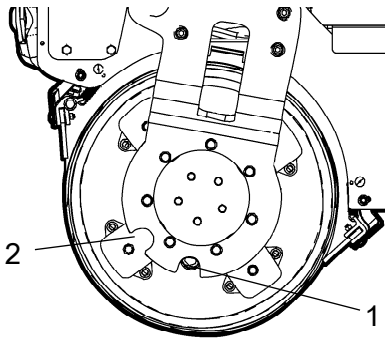

Fig. Drum, Drive side
1. Oil plug
2. Position for level check

Loosen the oil plug (1) slightly, when it is in position for level check (2), so that it can subsequently be unscrewed by hand.

Park the roller on a level surface, and drive the roller slowly until the plug (1) is in the bottom position.



Switch off the engine, disconnect the power and push in the reserve/parking brake knob.

Place a receptacle that will hold at least 4 liters (1 gal) under the plug.

Remove the plug (1) and let the oil run out.



Deliver the drained oil to special waste handling.

See under the section 'Every 500 hours of operation' for filling oil.



Water tank - Cleaning



Keep in mind that there is a risk of freezing in winter. Drain the tank, pump and lines.

Empty the tank.

Clean the tank with water and a suitable detergent for plastic surfaces.

Fill the tank with water and check that the sprinkler works.



The water tank is made of plastic (polyethylene) and is recyclable.

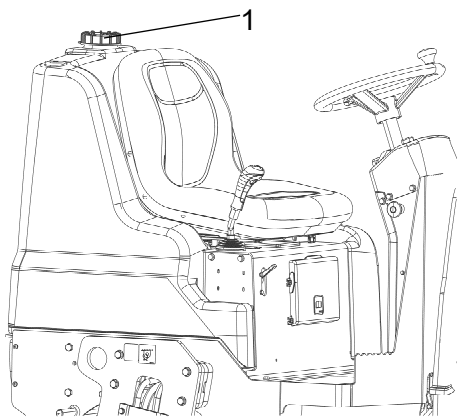

Fig. Water tank
1. Cap

