



Operator's Manual

Serial Number Range

GTH™-844

from GTH8E-11500

with
Maintenance
Information

Original Instructions
Fifth Edition
Sixth Printing
Part No. 1286013GT

Contents

Introduction	1
Symbol and Hazard Pictorials Definitions.....	5
General Safety	7
Work Area Safety	13
Legend	21
Controls.....	22
Inspections.....	27
Operating Instructions.....	40
Transport and Lifting Instructions	54
Maintenance	57
Attachments	64
Specifications.....	75
Load Charts	77

Copyright © 2012 by Terex Corporation

Fifth Edition: Sixth Printing, June 2024

Genie is a registered trademark of Terex South Dakota, Inc. in the U.S.A. and many other countries.

“GTH” is a trademark of Terex South Dakota, Inc.

Complies with ANSI/ITSDF B56.6, CSA B335



Introduction

About this manual

Genie appreciates your choice of our machine for your application. Our number one priority is user safety, which is best achieved by our joint efforts. This book is an operation and daily maintenance manual for the user or operator of a Genie machine.

This manual should be considered a permanent part of your machine and should remain with the machine at all times. If you have any questions, contact Genie.

Product Identification

The machine serial number is located on the serial label.

Serial label
(located inside
fork frame)
(models with
quick attach
frame)

Serial number
stamp

Serial label
(located inside
riser)

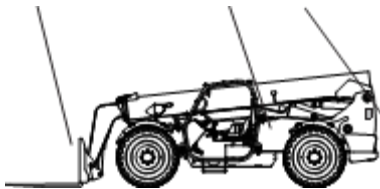

Intended Use

A variable reach rough terrain forklift truck is defined as a wheeled type truck with a pivoting boom, which may be equipped with various attachments for picking, transporting and placing loads with the established load range charts.

Use of this product in any other way is prohibited and contrary to its intended use.

Introduction

Bulletin Distribution and Compliance

Safety of product users is of paramount importance to Genie. Various bulletins are used by Genie to communicate important safety and product information to dealers and machine owners.

The information contained in the bulletins is tied to specific machines using the machine model and serial number.

Distribution of bulletins is based on the most current owner on record along with their associated dealer, so it is important to register your machine and keep your contact information up to date.

To ensure safety of personnel and the reliable continued operation of your machine, be sure to comply with the action indicated in a respective bulletin.

To view any open bulletins for your machine, visit us on the web at www.genielift.com.

Contacting the Manufacturer

At times it may be necessary to contact Genie. When you do, be ready to supply the model number and serial number of your machine, along with your name and contact information. At minimum, Genie should be contacted for:

Accident reporting

Questions regarding product applications and safety

Standards and regulatory compliance information

Current owner updates, such as changes in machine ownership or changes in your contact information. See Transfer of Ownership, below.

Transfer of Machine Ownership

Taking a few minutes to update owner information will ensure that you receive important safety, maintenance and operating information that applies to your machine.

Please register your machine by visiting us on the web at www.genielift.com or by calling us toll free at 1-800-536-1800.

Introduction



Danger

Failure to obey the instructions and safety rules in this manual will result in death or serious injury.

Do Not Operate Unless:

- You learn and practice the principles of safe machine operation contained in this operator's manual.
 - 1 **Avoid hazardous situations.**

Know and understand the safety rules before going on to the next section.

 - 2 Always perform a pre-operation inspection.
 - 3 Always perform function tests prior to use.
 - 4 Inspect the workplace.
 - 5 Only use the machine as it was intended.
- You read, understand and obey the manufacturer's instructions and safety rules—safety and operator's manuals and machine decals.
- You read, understand and obey employer's safety rules and worksite regulations.
- You read, understand and obey all applicable governmental regulations.
- You are properly trained to safely operate the machine.

Hazard Classification

Decals on this machine use symbols, color coding, and signal words to identify the following:



Safety alert symbol—used to alert you to potential personal injury hazards. Obey all safety messages that follow this symbol to avoid possible injury or death.



Indicates a hazardous situation which, if not avoided, will result in death or serious injury.



Indicates a hazardous situation which, if not avoided, could result in death or serious injury.



Indicates a hazardous situation which, if not avoided, could result in minor or moderate injury.



Indicates a property damage message.

Introduction

Standards

Many aspects of rough terrain forklift operation and testing are discussed in standards published by the American National Standards Institute and the Industrial Truck Standards Development Foundation. These standards are updated on a regular basis with addenda. It is recommended that you purchase and refer to the following standards.

ANSI/ITSDF B56.6 - Rough Terrain Forklift Trucks

The ANSI standard can be downloaded from www.ITSDF.org

CSA B335 - Safety Standard for Lift Trucks

The CSA standard can be downloaded from www.csa.ca









Safety Sign Maintenance

Replace any missing or damaged safety signs. Keep operator safety in mind at all times. Use mild soap and water to clean safety signs. Do not use solvent-based cleaners because they may damage the safety sign material.

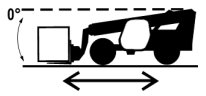
Symbol and Hazard Pictorials Definitions

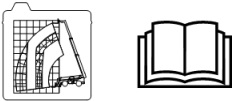
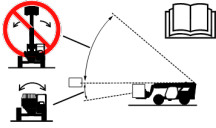
				
Electrocution hazard	Maintain required clearance	Crush hazard	No people under load	Read the operator's manual
				
Injection hazard	Use a piece of cardboard or paper to search for leaks	Maintain required clearance	Crush hazard	Always wear seat belt
				
Tip-over hazard	Tip-over hazard	Stay clear of moving telehandler	Crush hazard	
				
Keep away from moving parts	Burn hazard	Do not loosen cap until cool.	Explosion / Burn hazard	No smoking. No open flame.
				
Burn hazard	Allow surfaces to cool	Crush hazard	Keep away from moving parts	Access by trained and authorized personnel only

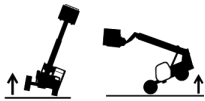
Symbol and Hazard Pictorials Definitions

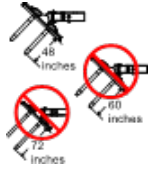
 <p>Explosion / Burn hazard</p>	 <p>No smoking. No open flame.</p>	 <p>Keep load low</p>	 <p>Fall hazard</p>	 <p>Only use an approved work platform</p>
 <p>Refer to load charts and manual.</p>	 <p>Sway operation</p>	 <p>Exterior emergency exit. Twist to remove security strip. Hit with force to break glass.</p>	 <p>Tip-over hazard</p>	 <p>Tip-over hazard</p>
 <p>Tip-over hazard</p>	 <p>Overturning hazard</p>			

General Safety

82558

⚠️ WARNING

Injection Hazard
Punching that under pressure can penetrate skin, causing serious injury.

Relieve pressure before disconnecting hydraulic lines. Keep away from leaks and pin holes. Use a pool of cardboard or paper to search for leaks. Do not use feet.

Fluid injected into skin must be surgically removed within a few hours, by a doctor familiar with this type of injury or gangrene will result.

3258 0

237605

⚠️ WARNING

Burn Hazard
Release of hot fluid under pressure can result in death or serious injury.

Do not loosen cap until cool.

237605 A

237601

⚠️ DANGER

Explosion / Burn Hazard
Battery explosion, fire or contact with hot surfaces and oil will result in death or serious injury.

Keep all open flames and sparks away.

Wear personal protective equipment, including face shield, gloves and long sleeves and pants. Read manuals. If you do not understand the information in the manuals, consult your supervisor, the owner or the manufacturer.

215268

⚠️ WARNING

Fall Hazard
Falling can result in death or serious injury.

When lifting personnel, utilize a work platform that meets OSHA requirements, along with considered overhead load limits.

Be sure to properly secure platform to backhoe loader platform.

Read and understand operator manual.

Properly and not personnel in operation equipment and other required to anchor provided.

1280264

⚠️ WARNING

Crush Hazard
Contact with moving chassis can result in death or serious injury.

Stay clear of moving chassis.

214418

⚠️ DANGER **⚠️ WARNING**

Electrocution Hazard
Contact with electric power lines will result in death or serious injury.

Stay clear of machine.

Crush Hazard
Contact with falling load can result in death or serious injury.

Stay clear of raised boom or load.

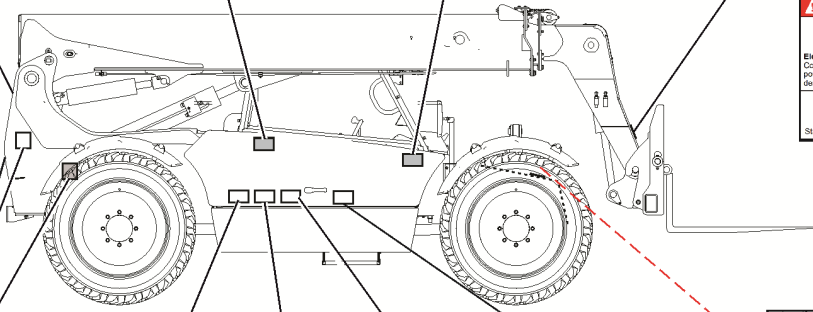

237970

⚠️ WARNING

Crush Hazard
Contact between wheel and chassis can result in death or serious injury.

Stay clear of machine during operation.

97602

⚠️ WARNING

Explosion Hazard
Death or serious injury can result from the use of other or other high energy starting aids.

Do not use either or other high energy starting aids on machines equipped with glow plugs or glow heater.

214418

⚠️ DANGER **⚠️ WARNING**

Electrocution Hazard
Contact with electric power lines will result in death or serious injury.

Stay clear of machine.

Crush Hazard
Contact with falling load can result in death or serious injury.

Stay clear of raised boom or load.

1263543

⚠️ WARNING

Warning Symbol
Improper operation or maintenance of this equipment can result in death or serious injury.

No Access Symbol
Access by trained and authorized personnel only.

1280294

⚠️ WARNING

Burn Hazard
Contact with hot surfaces can result in death or serious injury.

Stay clear of hot surfaces. Allow machine to cool before servicing.



General Safety

1285068

⚠ WARNING

Crush Hazard
Unrestrained contact with moving loader arm or bucket can result in death or serious injury.

Install loader arm support before servicing.

237971

⚠ DANGER

Explosion/Hazard
Fuel and fumes can explode and burn, resulting in death or serious injury.

No smoking. Keep all open flames and cigarettes away.

Stop engine before adding fuel.

237970

⚠ WARNING

Crush Hazard
Contact between wheel and chassis can result in death or serious injury.

Stay clear of machine during operation.

1280264

⚠ WARNING

Crush Hazard
Contact with moving telescopic boom can result in death or serious injury.

Stay clear of moving telescopic boom.

214419

⚠ DANGER	⚠ WARNING	⚠ WARNING	⚠ WARNING	⚠ WARNING	⚠ WARNING	⚠ WARNING

214418

⚠ DANGER	⚠ WARNING
Electrocution Hazard Contact with electric power lines will result in death or serious injury.	Crush Hazard Contact with falling load can result in death or serious injury.
Stay clear of machine.	Stay clear of raised boom or load.

237599

⚠ WARNING

Crush Hazard
Machine rollover can result in death or serious injury.

Always listen seat belt. Keep all body parts inside operator's cab at all times.

General Safety

1262614

WARNING

Do not use hoist. Do not use lift. Do not use truck boom or swing carriage.

Use only up to 1,22 m or shorter forks on swing carriage. Do not use truck boom or swing carriage.

1280888

WARNING

Crush Hazard
Contact with moving parts can result in serious injury.

Keep all body parts clear of moving parts during equipment operation.

1280888 A

1262614

WARNING

Do not use hoist. Do not use lift. Do not use truck boom or swing carriage.

Use only up to 1,22 m or shorter forks on swing carriage. Do not use truck boom or swing carriage.

1280888

WARNING

Crush Hazard
Contact with moving parts can result in serious injury.

Keep all body parts clear of moving parts during equipment operation.

1280888 A

82558

WARNING

Do not use hoist. Do not use lift. Do not use truck boom or swing carriage.

Use only up to 1,22 m or shorter forks on swing carriage. Do not use truck boom or swing carriage.

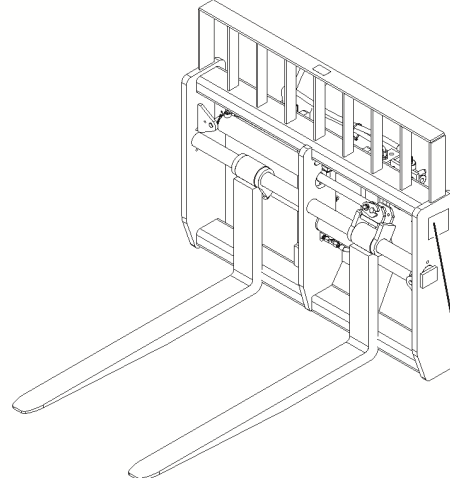
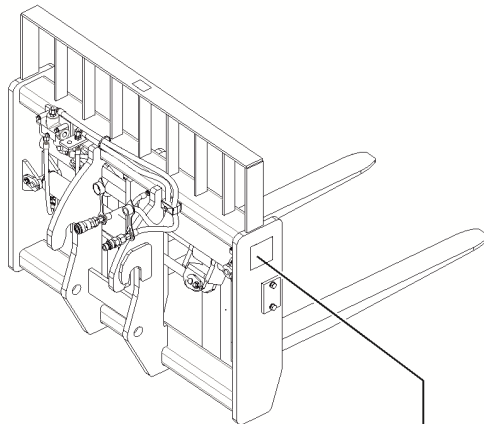
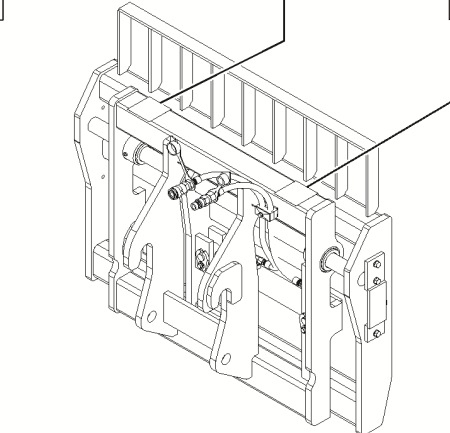
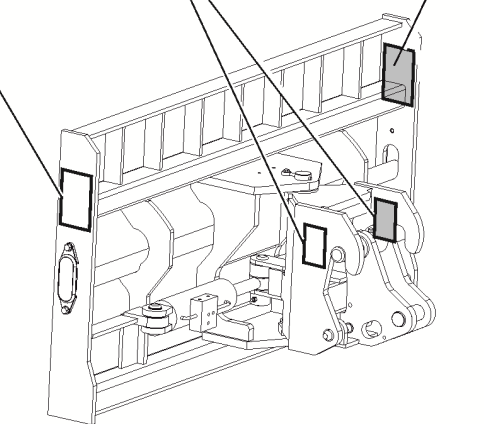

WARNING

Crush Hazard
Contact with moving parts can result in serious injury.

Keep all body parts clear of moving parts during equipment operation.

1280888 A

1280888

WARNING

Do not use hoist. Do not use lift. Do not use truck boom or swing carriage.

Use only up to 1,22 m or shorter forks on swing carriage. Do not use truck boom or swing carriage.

82558



General Safety

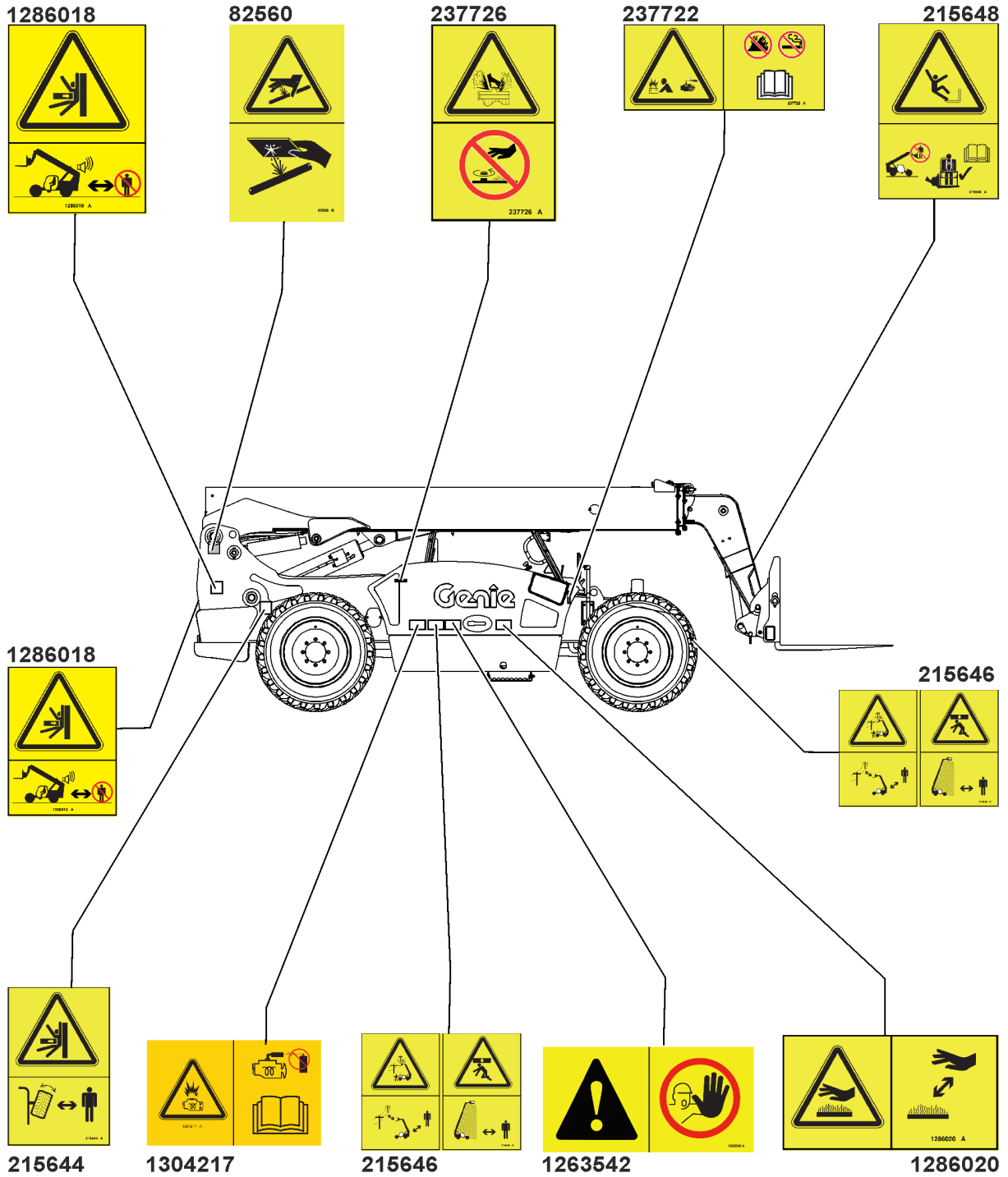

General Safety

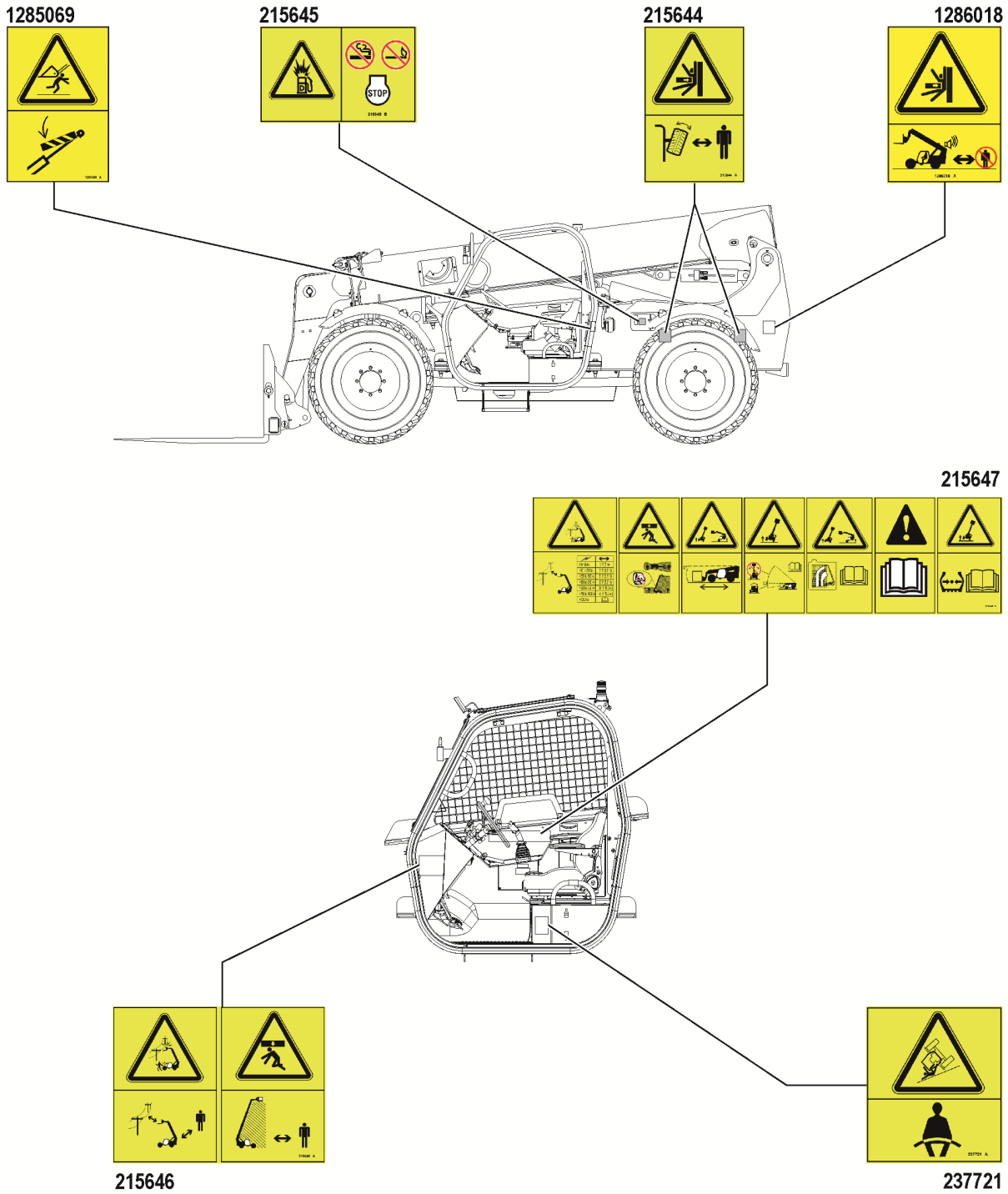

General Safety

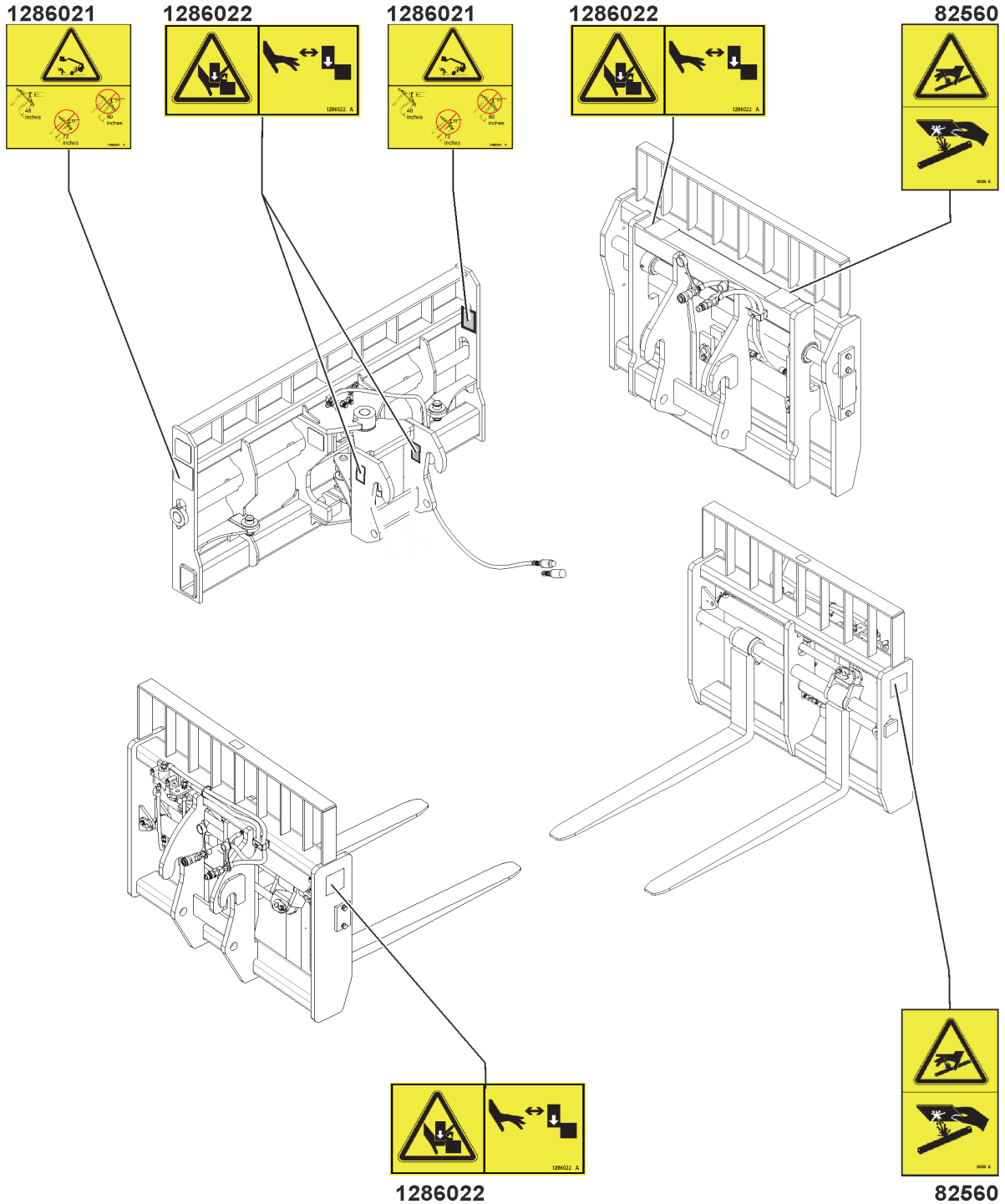

Work Area Safety

⚠ Tip-over Hazards



Using the appropriate load chart for the machine configuration, confirm that the load is within the rated capacity of the machine. Do not exceed the rated load.

The load center on the fork (if equipped) must be equal to or less than the load center indicated on the load chart. If the load center is further from the fork face than shown on the load chart, refer to the Load Chart section of this manual.

All loads shown on the load chart are based on the machine being on firm, level ground, the frame being level, the forks being positioned evenly on the carriage, the load being centered on the forks, the tires being properly sized and properly inflated, and the telehandler being in good operating condition.

If using accessories, read, understand and obey the decals, instructions and manuals with the accessory.

Do not raise the load unless the ground can support all forces imposed by the machine.

Do not lower a load without retracting the boom first.

Do not operate the machine if the load chart is missing.

Do not exceed the rated capacity for each configuration.

Do not attempt to jump free of the machine during a tip-over. The ROPS (Roll Over Protective Structure) is designed to protect you.



If the telehandler starts to tip over:

- Do not jump
- Brace yourself and stay in the seat
- Keep your seat belt fastened
- Hold on firmly
- Lean away from the point of impact
- Keep head, arms, hands, legs and all other body parts inside the operator's cab at all times.



Do not raise the boom unless the machine is level. The machine level indicator should be at zero degrees.

Do not level the machine using the frame sway control unless the boom angle indicator is at zero degrees or less.



Do not use the sway control to position an elevated load.

Work Area Safety

Do not raise a load and then drive to position it.

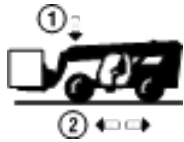

When driving, keep the boom at or below horizontal and keep the load close to the ground.

Operate the machine at speeds that will keep the load under control. Start and stop movements smoothly.



Do not raise a load unless the load is properly positioned or secured on the forks or approved attachment.

Do not operate the machine in strong or gusty winds. Do not increase the surface area of the carriage or load. Increasing the area exposed to the wind will decrease machine stability.

Use extreme care and slow speeds while driving the machine in the travel position across uneven terrain, steep grades, debris, unstable or slippery surfaces and near holes and drop-offs.

Do not alter or disable machine components that in any way affect safety and stability.

Do not replace items critical to machine stability with items of different weight or specification.

Do not replace factory-installed tires with tires of different specification or ply rating, unless approved by the factory.

If using accessories, read, understand and obey the decals, instructions and manuals with the accessory.

▲ Traveling on Slopes Hazards



When driving, keep the boom at or below horizontal and keep the load close to the ground.

When the machine is loaded, always travel with the load uphill. When the machine is unloaded, travel with the forks or attachment downhill.

On steep terrain, drive only up and down a hill, and always keep the machine in gear. Do not turn across the slope when the machine is traveling up or down a slope.

Limit travel path and speed according to the condition of the ground surface, traction, slope, location of personnel and any other factors which may create a hazard. Never drive the machine unless the mast and equipment are in their proper travel position.

Whether a machine will tip over during dynamic machine operation involves many factors that need to be considered. Among these are pavement/ground conditions, stability and slope, as well as machine equipment, operator skill, load position, tire inflation, machine speed, etc.

Additionally, tip-over of a machine is dependent in large part upon operator inputs such as the speed and smoothness of the operation, as well as the position of the attachment and its load.

Construction sites and roads will frequently change slope from place to place, can be hard and soft, and change due to construction activities and weather.

Work Area Safety

Operators should be properly trained and use their best judgment and experience to take the necessary precautions to prevent a tip-over.

Operators must assess the job site variables and avoid exceeding the machine's (or operator's) capabilities for terrain and conditions.

▲ Fall Hazards



Always wear a seat belt when operating the machine.

Always remain completely inside the cab when operating the machine.

When getting in and out of the cab, face the machine, use the steps and handrails provided and always maintain three-point contact.

Do not use the steering wheel or any other controls as handrails.



Do not allow riders on the machine or forks.



Do not lift personnel with this machine unless it is equipped with an approved work platform. See Work Platform section.

▲ Collision Hazards



Keep people, equipment and material out of the work area. Do not operate the machine while people are under or near an elevated boom, whether it is loaded or unloaded.

Do not put the transmission into gear unless the brake is applied and personnel and bystanders are clear of the machine and load.

Do not drive the machine if visibility is obstructed. Use a signal person when visibility is obstructed, and keep the signal person in view at all times. Use prearranged hand signals to communicate.

Do not raise the boom unless the brake is applied.

Do not operate, without fenders, in conditions where loose debris could hit the operator or accumulate on the cab windows.

Do not operate the machine with a faulty back-up alarm. The back-up alarm should sound when the machine is in reverse.

Do not operate the machine in low light conditions. An optional work and road light package is available.

Operators must comply with employer, job site, and governmental rules regarding use of personal protective equipment.

Do not drive the machine directly up to anyone.

Work Area Safety

Always make sure that mirrors and cab glass are clean and do not obstruct the operators view of the travel path or load.

Scan the area prior to operating the machine. Look in the direction of travel. Use mirrors to assist in checking all around the machine.

Keep windows and mirrors clean, adjusted and in good repair.

Be aware of the machine load swing area.

Do not rely on the rear proximity alarm system to determine if personnel or objects are behind the machine. The system has limitations due to maintenance practices, the size or shape of the object, composition, environmental conditions and operating range. This system is set up for detection at a reverse speed of a maximum of 3 feet per second / 0.9 meters per second (walking pace). Refer to the detection zone chart in the back of this manual.

⚠ Falling Object Hazards

Operate the machine at speeds that will keep the load under control. Start and stop movements smoothly.



Keep people, equipment and material out of the work area. Do not operate the machine while people are under or near an elevated boom, whether it is loaded or unloaded.

Be sure the load is secure before lifting it. Always make sure the quick attach pin is inserted and secured.

⚠ Bodily Injury Hazards



Always adjust the seat and fasten the seat belt before starting the engine.



Do not operate the machine with a hydraulic oil or air leak. An air leak or hydraulic leak can penetrate and/or burn skin. Relieve pressure before disconnecting hydraulic lines. Keep away from leaks and pin holes. Use a piece of cardboard or paper to search for leaks. Do not use your hand.



Fluid injected into skin must be surgically removed within a few hours by a doctor familiar with this type of injury or gangrene will result.



Stay clear of belts and fans when the engine is running.

Always operate the machine in a well-ventilated area to avoid carbon monoxide poisoning.

Improper contact with components under any cover will cause serious injury. Only trained maintenance personnel should access compartments. Access by the operator is only advised when performing a pre-operation inspection. All compartments must remain closed and secured during operation.

Keep body parts, such as hand, fingers and arms, away from moving components.

Always use provided latches and handles for opening and closing doors and covers.

Work Area Safety

▲ Damaged Machine Hazards

Do not use a damaged or malfunctioning machine.

Conduct a thorough pre-operation inspection of the machine and test all functions before each work shift. Immediately tag and remove from service a damaged or malfunctioning machine.

Be sure all maintenance has been performed as specified in this manual and the appropriate Genie service manual.

Be sure all decals are in place and legible.

Be sure the operator's and safety manuals are complete, legible and in the storage container located in the cab.

Do not attempt to start the machine by towing or pushing.

Do not attempt to use the forks or attachments for prying wedged or frozen loads free.

Do not push or pull objects or loads with the forks, attachment or boom.

If engine display lights or engine condition indicator lights are on, see the Operating Instructions section. Continued use when engine lights are on could result in reduced torque and engine speed.

▲ Component Damage Hazards

Do not use any battery or charger greater than 12V to jump-start the engine.

Do not use the machine as a ground for welding.

Do not steer the front tires on dry pavement when the axle differential lock is activated.

Do not lock the axle differential when the machine is moving.

For machines equipped with solid tires, do not operate continuously for longer than one hour without allowing the tires to cool down for 30 minutes.

Do not operate the machine when the SCR (selective catalytic reduction) cleaning operation is running. See Operating Instructions section.

Diesel exhaust fluid (DEF) is corrosive to metal and paint. If DEF is spilled, it should be cleaned up immediately with warm water.

Work Area Safety

▲ Crush Hazards

Keep clear of moving parts during machine operation and make sure personnel and bystanders are kept clear of moving parts during operation.

Set the parking brake, put the transmission in neutral and lower the carriage or the attachment to the ground before leaving the machine.

Keep clear of elevated components.

Support components before performing service. Keep clear of moving parts during machine operation and make sure personnel and bystanders are kept clear of moving parts during operation.

Do not work under the boom without the cylinder chock in place.

▲ Burn Hazards



Allow hot surfaces to cool before touching or servicing.

▲ Explosion and Fire Hazards

Do not start the engine if you smell or detect liquid petroleum gas (LPG), gasoline, diesel fuel or other explosive substances.

Do not refuel the machine with the engine running.



Refuel the machine and charge the battery only in an open, well-ventilated area away from sparks, flames and lighted tobacco.

Do not operate the machine in hazardous locations or locations where potentially flammable or explosive gases or particles may be present.

Do not spray ether into engines equipped with glow plugs or air intake grid heaters.

Work Area Safety

⚠ Electrocutation Hazards

This machine is not electrically insulated and will not provide protection from contact with or proximity to electrical current.



Obey all local and governmental regulations regarding required clearance from electrical power lines. At a minimum, the required clearance contained in the chart below must be followed.



Always contact the electrical power line owner. The electrical power shall be disconnected or the power lines moved or insulated before machine operations begin.

Allow for boom and attachment movement, electrical line sway or sag, and beware of strong or gusty winds.

Keep away from the machine if it contacts energized power lines. Personnel on the ground or in the cab must not touch or operate the machine until energized power lines are shut off.

Do not operate the machine during lightning or storms.

Line Voltage	Required Clearance	
0 to 50KV	10 ft	3.05 m
>50 to 200KV	15 ft	4.60 m
>200 to 350KV	20 ft	6.10 m
>350 to 500KV	25 ft	7.62 m
>500 to 750KV	35 ft	10.67 m
>750 to 1000KV	45 ft	13.72 m
over 1000kV	see below	

For power lines over 1000kV, the minimum clearance distance must be established by the utility owner or operator or by a registered professional engineer who is a qualified person with respect to electrical power transmission and distribution.

Do not use the machine as a ground for welding.

Work Area Safety

⚠ Battery Safety

Burn Hazards



Batteries contain acid. Always wear protective clothing and eye wear when working with batteries.

Avoid spilling or contacting battery acid. Neutralize battery acid spills with baking soda and water.

⚠ Employer's Responsibilities

Employers are responsible for providing a safe work environment and for complying with local and national governmental regulations.

Explosion Hazards



Keep sparks, flames, and lighted tobacco away from batteries. Batteries emit explosive gas.

⚠ Electrocutation Hazard

Avoid contact with electrical terminals.

Legend

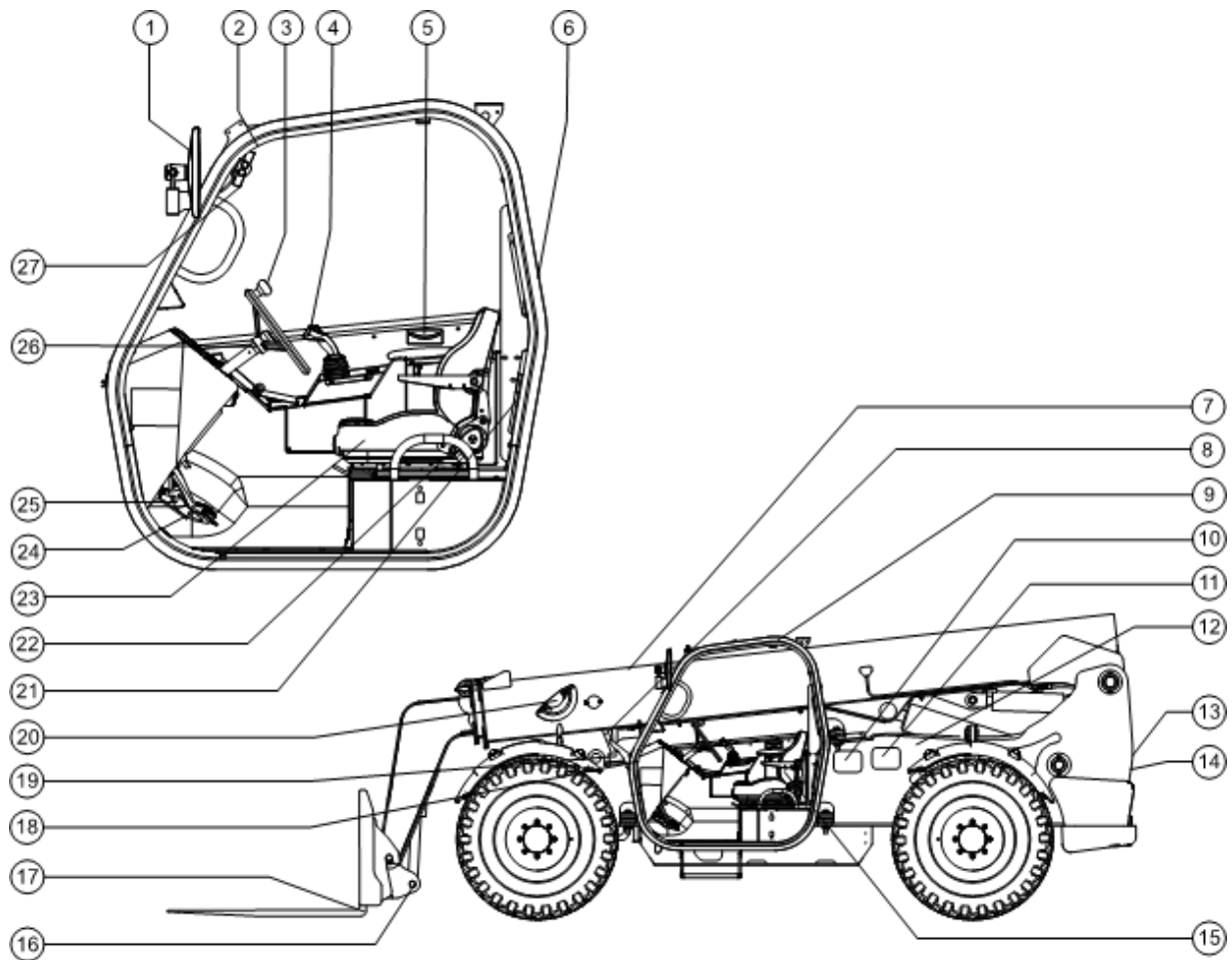

- | | |
|--------------------------------------------------------|--------------------------------------------------------------|
| 1 Interior rear view mirror | 14 Rear proximity alarm sensor (if equipped) |
| 2 Left to right level indicator | 15 Fuse panel |
| 3 Steering wheel | 16 Shackle lifting point |
| 4 Control handle | 17 Forks |
| 5 Front to rear level indicator | 18 SCR cleaning operation switch (under cover) (if equipped) |
| 6 Exterior emergency exit (Safe T Punch) (if equipped) | 19 Hydraulic oil level gauge (under cover) |
| 7 Boom | 20 Boom angle indicator |
| 8 Cab | 21 Operator's manual |
| 9 Exterior rear view mirror | 22 Seat belt |
| 10 DEF fill location (if equipped) | 23 Seat |
| 11 Diesel fill location | 24 Brake pedal |
| 12 Engine (on opposite side of machine) | 25 Accelerator pedal |
| 13 Backup camera (if equipped) | 26 Transmission control lever |
| | 27 Monitor, backup camera (if equipped) |

Controls

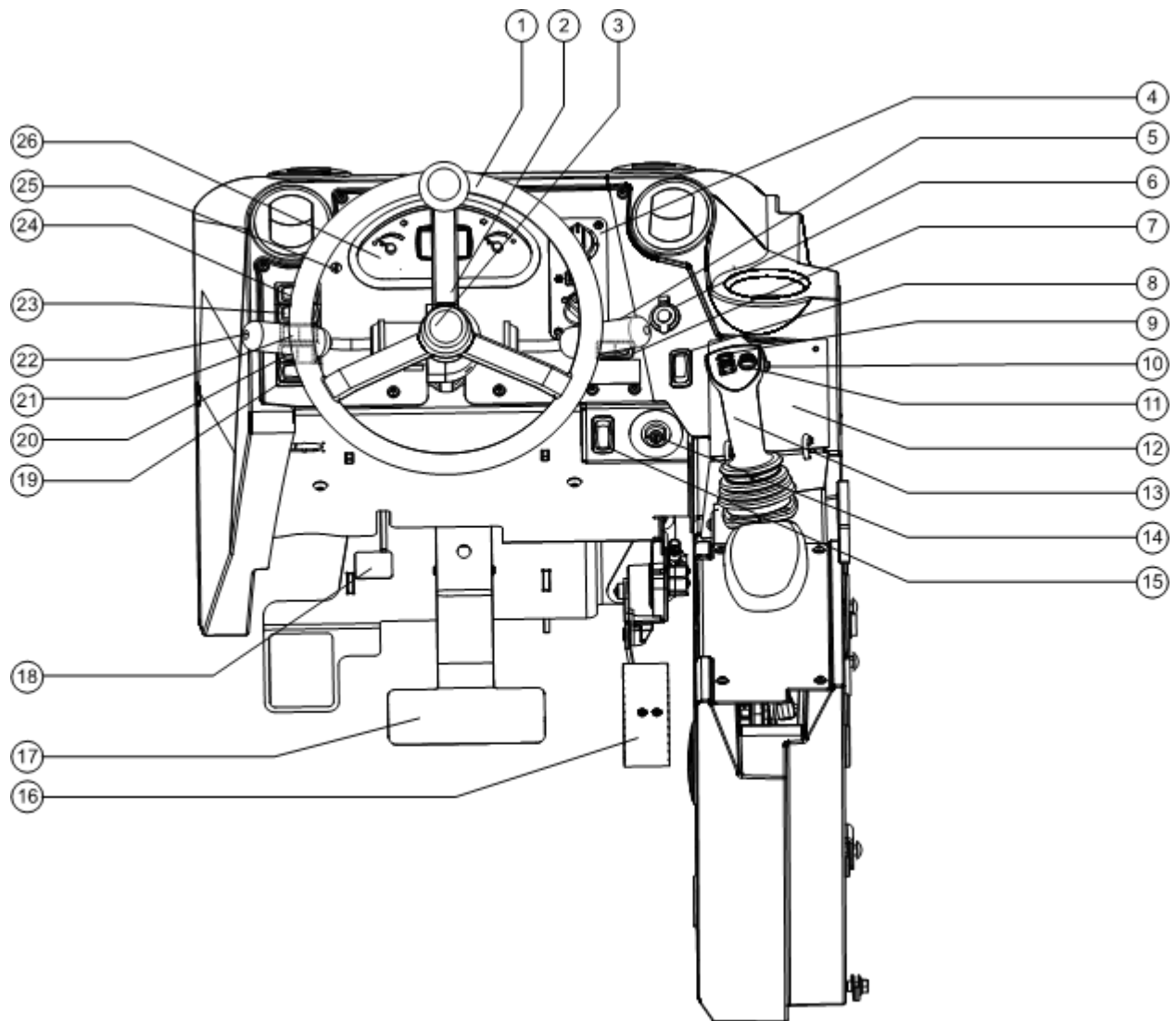

Control Panel

1 Steering wheel

Turn the steering wheel to the right to turn the front wheels to the right. Turn the steering wheel to the left to turn the front wheels to the left.

2 Rear proximity display and alarm (if equipped)

3 Horn button

Press this button and the horn will sound. Release the button and the horn will stop.

4 Heater and air conditioning controls (if equipped)

Controls

- 5 Turn signal lever (if equipped)
Move the lever up to activate the left turn signal. Move the lever down to activate the right turn signal. Turn the lever to turn on the hazard lights.
- 6 12V power port, 10A maximum
- 7 Steer select switch
Push down the right side of the rocker switch to select four-wheel steer. Push the rocker switch to the middle position to select two-wheel steer. Push down the left side of the rocker switch to select crab steer.
- 8 Axle differential lock switch
Push and hold the axle differential lock switch to lock the axle differential. Release the switch to unlock the axle differential.
- 9 Yellow roller
Pull the yellow roller down/back and the forks will tilt up. Push the yellow roller up/forward and the forks will tilt down.
- 10 White finger switch
Hold the white finger switch and push the control handle to the right and the machine will sway to the right. Hold the white finger switch and pull the control handle to the left and the machine sway to the left.
- 11 Auxiliary hydraulics thumb rocker
Push the auxiliary hydraulics thumb rocker to the left and the carriage will open the forks, swing, rotate or move to the left. Push the auxiliary hydraulics thumb rocker to the right and the carriage will close the forks, swing, rotate or move to the right.
- 12 Load charts
- 13 Control handle (electronic)
Pull the control handle back and the boom will raise. Push the control handle forward and the boom will lower. Push the control handle to the right and the boom will extend. Pull the control handle to the left and the boom will retract.
- 14 Ignition switch
Turn the key to the left to turn on the accessories. Turn the key to the on position and hold until the glow plug light on the instrument panel turns off. Turn the key to the start position to start the engine.
- 15 Parking brake switch
Push the top of the rocker switch to turn the parking brake on. The light will be on when the parking brake is on. Push the bottom of the rocker switch to turn the parking brake off. The light will be off when the parking brake is off.
- 16 Accelerator pedal

Controls

- 17 Brake pedal
- 18 Tilt steering pedal
Push and hold the tilt steering pedal to release the steering column. Move the steering wheel to desired position and release the pedal.
- 19 Windshield washer/wiper switch (if equipped)
Push the right side of the rocker switch to turn the wiper on. Push and hold the right side of the rocker switch to turn the washer on. Release the switch to turn the washer off. Push the left side of the rocker switch to turn the wiper off.
- 20 Skylight washer/wiper switch (if equipped)
Push the right side of the rocker switch to turn the wiper on. Push and hold the right side of the rocker switch to turn the washer on. Release the switch to turn the washer off. Push the left side of the rocker switch to turn the wiper off.
- 21 Lights switch (if equipped)
Push the top of the rocker switch to turn the lights on. Push the bottom of the rocker switch to turn the lights off.
- 22 Transmission control lever
Move the transmission control lever toward you and move it up for forward gear. Move the lever toward you and move it down for reverse gear. Move the lever to the center position for neutral. Turn the lever clockwise to shift to a lower speed. Turn the lever counterclockwise to shift to a higher speed.
- 23 Boom lights switch (if equipped)
Push the right side of the rocker switch to turn the boom lights on. Push the left side of the rocker switch to turn the boom lights off.
- 24 Not used
- 25 Diagnostic button (if equipped)
Push and hold the button for 5 seconds to display error codes. If more than one error code is displayed, continue to push button to view all codes. After all codes are displayed, push and hold button for 5 seconds to return to home screen.
- 26 Instrument panel

Controls

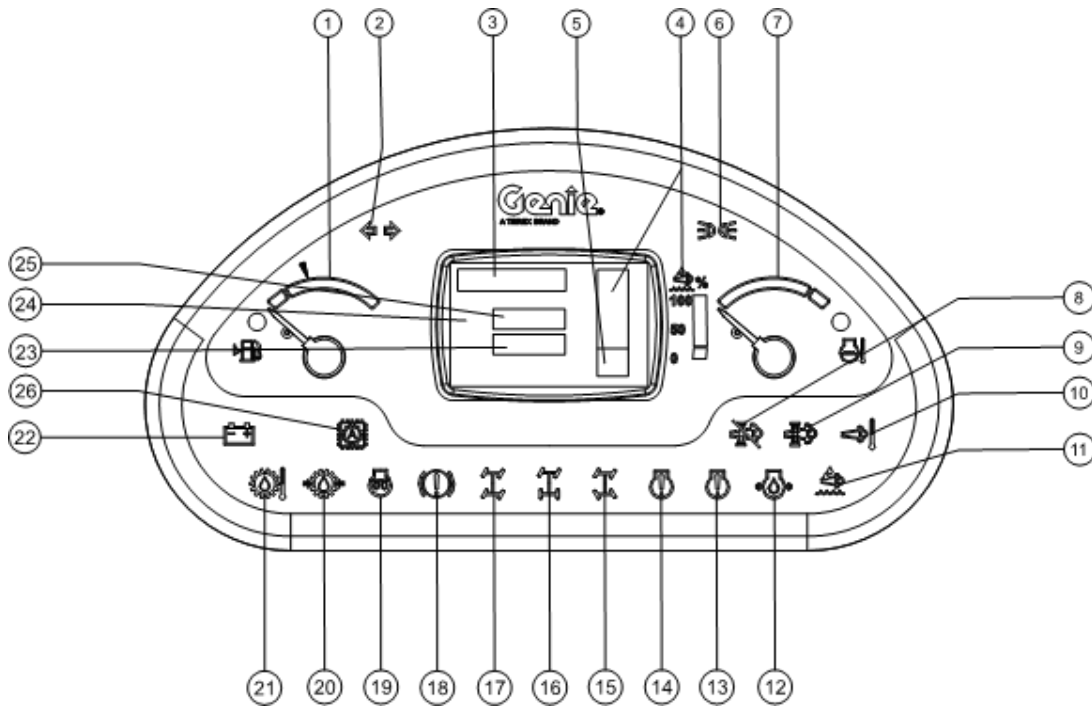

or

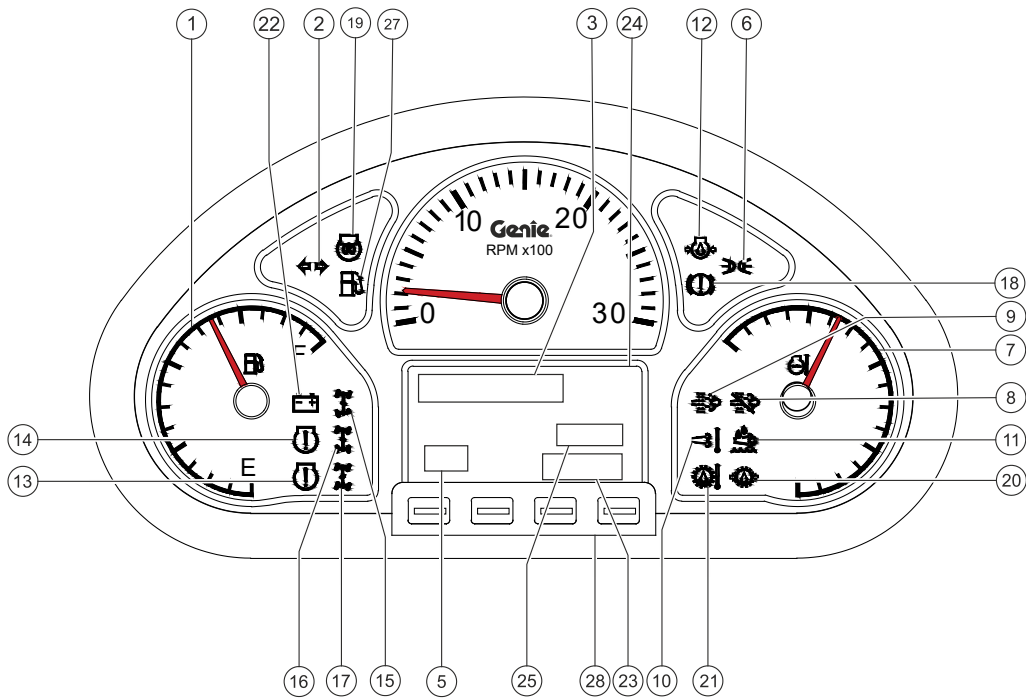

Controls

Instrument Panel

- | | |
|----------------------------------------------------------------------------------------------|--------------------------------------------------------------|
| 1 Fuel level gauge with low fuel indicator light | 12 Engine oil pressure low indicator light |
| 2 Turn signal indicator lights | 13 Check engine indicator light |
| 3 Error code messaging | 14 Engine stop indicator light |
| 4 DEF (diesel exhaust fluid) Level (if equipped) | 15 Four-wheel steer indicator light |
| 5 Engine identification | 16 Two-wheel steer indicator light |
| 6 Lights indicator light | 17 Crab steer indicator light |
| 7 Engine coolant temperature gauge | 18 Brake pressure low indicator light |
| 8 Engine emissions standstill (regeneration) disabled indicator light | 19 Glow plug indicator light |
| 9 Engine emissions standstill requested/active indicator light | 20 Transmission oil pressure low indicator light |
| 10 Engine emissions exhaust temperature high/standstill on-going light | 21 Transmission oil temperature high indicator light |
| 11 Engine emissions diesel exhaust level (DEF)/quality/tampering/malfunction indicator light | 22 Battery voltage low indicator light |
| | 23 Hour meter |
| | 24 Display screen (or) Display screen with Four Button Panel |
| | 25 Tachometer |
| | 26 Torque Optimized Indicator Light (if equipped) |
| | 27 Low fuel indicator light (if equipped) |
| | 28 Four button panel (if equipped) |

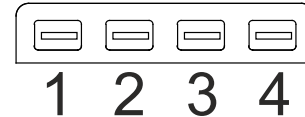

- 1 Up
- 2 Down
- 3 Menu/Enter
- 4 Esc

Inspections



Do Not Operate Unless:

- ☑ You learn and practice the principles of safe machine operation contained in this operator's manual.
 - 1 Avoid hazardous situations.
 - 2 **Always perform a pre-operation inspection.**
- Know and understand the pre-operation inspection before going on to the next section.**
 - 3 Always perform function tests prior to use.
 - 4 Inspect the workplace.
 - 5 Only use the machine as it was intended.

Pre-operation Inspection Fundamentals

It is the responsibility of the operator to perform a pre-operation inspection and routine maintenance.

The pre-operation inspection is a visual inspection performed by the operator prior to each work shift. The inspection is designed to discover if anything is apparently wrong with a machine before the operator performs the function tests.

The pre-operation inspection also serves to determine if routine maintenance procedures are required. Only routine maintenance items specified in this manual may be performed by the operator.

Refer to the list on the next page and check each of the items.

If damage or any unauthorized variation from factory delivered condition is discovered, the machine must be tagged and removed from service.

Repairs to the machine may only be made by a qualified service technician, according to the manufacturer's specifications. After repairs are completed, the operator must perform a pre-operation inspection again before going on to the function tests.

Scheduled maintenance inspections shall be performed by qualified service technicians, according to the manufacturer's specifications and the requirements listed in the responsibilities manual.

Inspections

Pre-operation Inspection

- Be sure that the operator's and safety manuals are complete, legible and in the storage container located in the cab.
- Be sure that all decals are legible and in place. See Inspections section.
- Be sure that all load charts are legible and in place.
- Check for hydraulic oil leaks and proper oil level. Add oil if needed. See Maintenance section.
- Check for battery fluid leaks and proper fluid level. Add distilled water if needed. See Maintenance section.
- Check the electrical connections to the battery disconnect switch, and the key switch position (if equipped)
- Check the transmission oil level. Add oil if needed. See Maintenance section.
- Check DEF level. See Maintenance section. (if equipped).
- Drain the fuel/water separator. See Maintenance section.
- Check for engine oil leaks and proper oil level. Add oil if needed. See Maintenance section.
- Air-filled tires models: Check for proper tire pressure. Add air if needed. See Maintenance section.
-

Check the following components or areas for damage, improperly installed, or missing parts and unauthorized modifications:

- Electrical components, wiring, and electrical cables
- Hydraulic hoses, fittings, cylinders, and manifolds

- Fuel and hydraulic tanks
- Axles and transmission
- Boom wear pads
- Load charts and angle indicators
- Tires and wheels
- Engine and related components
- Limit switches
- Lights, alarms and beacons (if equipped)
- Seat belts
- Pins, nuts, bolts and other fasteners
- Attachments

Check entire machine for:

- Cracks in welds or structural components
- Dents or damage to machine
- Excessive rust, corrosion or oxidation
- Be sure that only 48-inch forks are used with swing carriage.
- Verify that all structural and other critical components are present and all associated fasteners and pins are in place and properly tightened.
- Be sure the windshield and windows (if equipped) are clean and free of obstructions that might limit visibility.
- Be sure the rear proximity alarm, display, monitor, camera and sensor (if equipped) are present, in place and clear of any dirt, mud, snow or debris.
- After you complete your inspection, be sure that all guards, screens and compartment covers are in place and secured.

Inspections



Do Not Operate Unless:

- You learn and practice the principles of safe machine operation contained in this operator's manual.
 - 1 Avoid hazardous situations.
 - 2 Always perform a pre-operation inspection.
 - 3 Always perform function tests prior to use.**

Know and understand the function tests before going on to the next section.

- 4 Inspect the workplace.
- 5 Only use the machine as it was intended.

Function Test Fundamentals

The function tests are designed to discover any malfunctions before the machine is put into service. The operator must follow the step-by-step instructions to test all machine functions.

A malfunctioning machine must never be used. If malfunctions are discovered, the machine must be tagged and removed from service. Repairs to the machine may only be made by a qualified service technician, according to the manufacturer's specifications.

After repairs are completed, the operator must perform a pre-operation inspection and function tests again before putting the machine into service.

Inspections

Function Tests

- 1 Select a test area that is firm, level and free of hazards. Be sure there is no load on the forks or attachment.
- 2 Enter the cab and sit on the seat.
- 3 Adjust the seat and steering column, if needed.
- 4 Fasten the seat belt.
- 5 Adjust the mirrors, if required.
- 6 Be sure the parking brake is on and the transmission control is in neutral.
- 7 Start the engine. See Starting the Engine in the Operating Instructions section.

Test the Horn

- 8 Press the horn button.
- ⊙ Result: The horn should sound.

Test the Electronic Joystick Handle

- 9 Using the control handle, momentarily raise the boom, extend the boom, retract the boom and lower the boom.
⊙ Result: All functions should operate smoothly.
- 10 Using the yellow roller, momentarily tilt the forks up and tilt the forks down.
⊙ Result: All functions should operate smoothly.
- 11 Using the control handle and the white finger switch, momentarily sway the machine to the right and to the left.
⊙ Result: The frame level function should operate smoothly.

Inspections

Test the Steering

- 12 Push the right side of the steer selector switch to select four-wheel steer. The four-wheel steer indicator light on the instrument panel will be on.
- 13 Check the steering operation by turning the steering wheel approximately a quarter turn in each direction.
 - ⦿ Result: The front wheels should turn in the same direction as the steering wheel.
- 14 Straighten the wheels.
- 15 Push the steer selector switch to the middle position to select two-wheel steer. The two-wheel steer indicator light on the instrument panel will be on.
- 16 Check the steering operation by turning the steering wheel approximately a quarter turn in each direction.
- 17 Straighten the wheels.
- 18 Push the left side of the steer selector switch to select crab steer. The crab steer indicator light on the instrument panel will be on.
- 19 Check the steering operation by turning the steering wheel approximately a quarter turn in each direction.
 - ⦿ Result: The front wheels and the rear wheels should turn in the same direction as the steering wheel.

Test the Ignition System

- 20 Set the transmission control lever in neutral position.
- 21 Turn off the engine.
- 22 Step on the brake pedal. Push the top of the parking brake switch to turn it on.
- 23 Turn the key switch to start the engine.
 - ⦿ Result: The engine should start.
- 24 Set the transmission control lever in gear.
- 25 Push the bottom of the parking brake switch to turn it on.
- 26 Turn the key switch to start the engine.
 - ⦿ Result: The engine should not start.

Test the Transmission and Brakes

- 27 Fully retract the boom and lower it to the travel position.
- 28 Step on the brake pedal. Push the bottom of the parking brake switch to turn it off.
- 29 Move the transmission control lever to forward. Slowly let up on the brake pedal. As soon as the machine starts to move, push the brake pedal.
 - ⦿ Result: The machine should move forward, and then come to an abrupt stop.

Inspections

- 30 Move the transmission control lever to reverse. Slowly let up on the brake pedal. As soon as the machine starts to move, push the brake pedal.
- ⦿ Result: The machine should move in reverse, and then come to an abrupt stop. The back-up alarm should sound when the transmission control lever is in reverse.
- 31 Move the transmission control lever to neutral.
- 32 Push the top of the parking brake switch.
- ⦿ Result: The red parking brake indicator light should come on, indicating the parking brake is on.
- 33 Move the transmission control lever forward, and then in reverse.
- 34 Slowly let up on the brake pedal.
- ⦿ Result: The machine should not move.

Test Auxiliary Hydraulics

- 35 Push the auxiliary hydraulics thumb rocker to the left and the carriage will open the forks, swing, rotate or move to the left. Push the auxiliary hydraulics thumb rocker to the right and the carriage will close the forks, swing, rotate or move to the right.
- ⦿ Result: The function should operate smoothly.

Test the Drive and Sway Cutout

- 36 Raise the boom to 55°. Do not extend the boom.
- 37 Step on the brake pedal.
- 38 Push the bottom of the parking brake switch. The parking brake is off when the indicator light is off.
- 39 Put the transmission control lever in forward.
- ▲ Slowly let up on the brake pedal.
 - ⦿ Result: The drive function should not operate.
- 40 Put the transmission control lever in neutral.
- 41 Push the top of the parking brake switch.
- ▲ Slowly sway the machine to the left and to the right.
 - ⦿ Result: The sway function should not operate.

Test the Lights (if equipped)

- 42 Verify that all lights are functional.

Inspections

Test the 3-speed Transmission (if equipped)

- 43 Fully retract the boom and lower it to the travel position.
- 44 Drive the machine forward. Rotate the control lever to shift the transmission to second gear.
 - ⦿ Result: The machine should shift to second gear.
- 45 Drive the machine forward. Rotate the control lever to shift the transmission to third gear.
 - ⦿ Result: The machine should shift to third gear.

Test the Rear Proximity Alarm System (if equipped)

The system provides a visible and audible indication of objects behind the machine, when they are within the detection range of the sensor and while in reverse gear.

Be sure that there are no personnel and obstacles behind the machine which the sensor may detect on startup.

- 46 Locate a sizable item, like a safety cone or pallet of bricks, that the sensor will detect and position the rear of the telehandler about 15 feet/4.5 m in front of it. Do not perform the function test if there are people behind the machine.
- 47 Set the parking brake, place the transmission into neutral and start the engine. Press and hold the brake pedal and place the transmission in reverse.
 - ⦿ Result: The green light on the rear proximity display/monitor should be on. If the green light is not on, the system needs to be repaired.
- 48 Release the parking brake and slowly let up on the brake pedal and slowly approach the object. Stop the machine before it reaches the object.
 - ⦿ Result: The rear proximity display/monitor should show a red light on. The alarm should sound with increased frequency as the machine approaches the object.
- 49 Place the transmission in forward and slowly drive away from the object.
 - ⦿ Result: The rear proximity display/monitor should show an orange light on, and the alarm should sound with decreased frequency as the machine moves away from the object.
 - ⦿ Result: As the machine moves away from the object, the display should show the green light on, and no alarm should be sounding.
- 50 Stop the machine, place the transmission in neutral and turn off the engine.

Inspections

Test the Back-up Camera (if equipped)

- 51 Press and hold the brake pedal and place the transmission in reverse.
 - ⦿ Result: The monitor will switch to a full screen showing only the rear camera view. If the monitor does not show the rear camera view, the system needs to be repaired.
- 52 Turn off the engine.

Inspections



Do Not Operate Unless:

- You learn and practice the principles of safe machine operation contained in this operator's manual.
 - 1 Avoid hazardous situations.
 - 2 Always perform a pre-operation inspection.
 - 3 Always perform function tests prior to use.
 - 4 Inspect the workplace.**

Know and understand the workplace inspection before going on to the next section.
 - 5 Only use the machine as it was intended.

Workplace Inspection Fundamentals

The workplace inspection helps the operator determine if the workplace is suitable for safe machine operation. It should be performed by the operator prior to moving the machine to the workplace.

It is the operator's responsibility to read and remember the workplace hazards, then watch for and avoid them while moving, setting up, and operating the machine.

Workplace Inspection Checklist

Be aware of and avoid the following hazardous situations:

- drop-offs or holes
- bumps, floor obstructions, or debris
- sloped surfaces
- unstable or slippery surfaces
- overhead obstructions and high voltage conductors
- hazardous locations
- inadequate surface support to withstand all load forces imposed by the machine
- wind and weather conditions
- the presence of unauthorized personnel
- other possible unsafe conditions

Inspections

Inspection for Decals with Words

Determine whether the decals on your machine have words or symbols. Use the appropriate inspection to verify that all decals are legible and in place.

Part No.	Decal Description	Qty
28159	Label – Diesel	1
38149	Label – Patent	1
82366	Label – Chevron Rando*	1
82558	Warning – Skin Injection Hazard	1
97602	Warning – Explosion Hazard	1
114090	Label – Transmission Control	1
114115	Label – Steer Model Selector	1
133206	Label – Emergency Exit	1
160482	Label – Transport and Lifting*	1
214418	Danger/Warning – 2 Decal Combination	3
214419	Danger/Warning – 6 Decal Combination	1
215268	Warning – Fall Hazard, Work Platform	1
215384	Label – FOPS/ROPS	1
219648	Label – Load Chart, Rotate Carriage*	1
220271	Label – Boom Lettering	1
237599	Warning – Bodily Injury Hazard	1
237601	Danger – Explosion/Burn Hazard	1
237605	Warning – Burn Hazard, Hot Parts	1
237684	Label - Load Chart, Standard Carriage*	1
237863	Label – Angle Indicator	1
237970	Warning – Crush Hazard, Tires	3
237971	Danger – Explosion/Burn Hazard, Fueling	1
826345	Label – Ultra Low Sulfur Fuel Only (diesel models)	1
1253091	Label – Key Ignition	1
1255823	Label – 3-speed Transmission	1

Part No.	Decal Description	Qty
1257919	Label – Load Chart, Quick Attach Lifting Point*	1
1261896	Label – Load Chart, Swing*	1
1262614	Warning – Tip-over, Swing Carriage	2
1263543	Warning – Compartment Access	1
1266019	Label – Shell Tellus	1
1268754	Label – DEF Fill	1
1268755	Serial Plate	1
1269532	Label – Exterior Emergency Exit	1
1272242	Label – Machine Registration/Owner Transfer	1
1272926	Label – Fuse and Relay Panel	1
1276041	Label – Fill Level, Tank, 20 gal	1
1280264	Warning – Crush Hazard, Moving Machine	3
1280294	Warning – Burn Hazard	1
1280819	Label – Warning, Prop 65	1
1280820	Label – Fuel, Diesel Exhaust, Prop 65	1
1280888	Warning – Crush Hazard, Moving Parts	1
1284367	Label – Electronic Controller	1
1285068	Warning – Safety Chock	1
1307976	Decal – Switch, Ignition, 3-Position	1
1323877	Decal – 4000 LBS Cap	1
1323878	Decal – 2000 LBS Cap	1
1323879	Decal – 3000 LBS Cap	1
1325939	Label – Load Chart, GTH-844 Truss Boom*	1
1325945	Label – Load Chart, GTH-844 Bucket*	1
1328114	Label – Load Chart, GTH-844 Side Shift*	1
1328115	Label – Load Chart, GTH-844 Fork Positioner*	1

* These decals are model, option or configuration specific.

Inspections

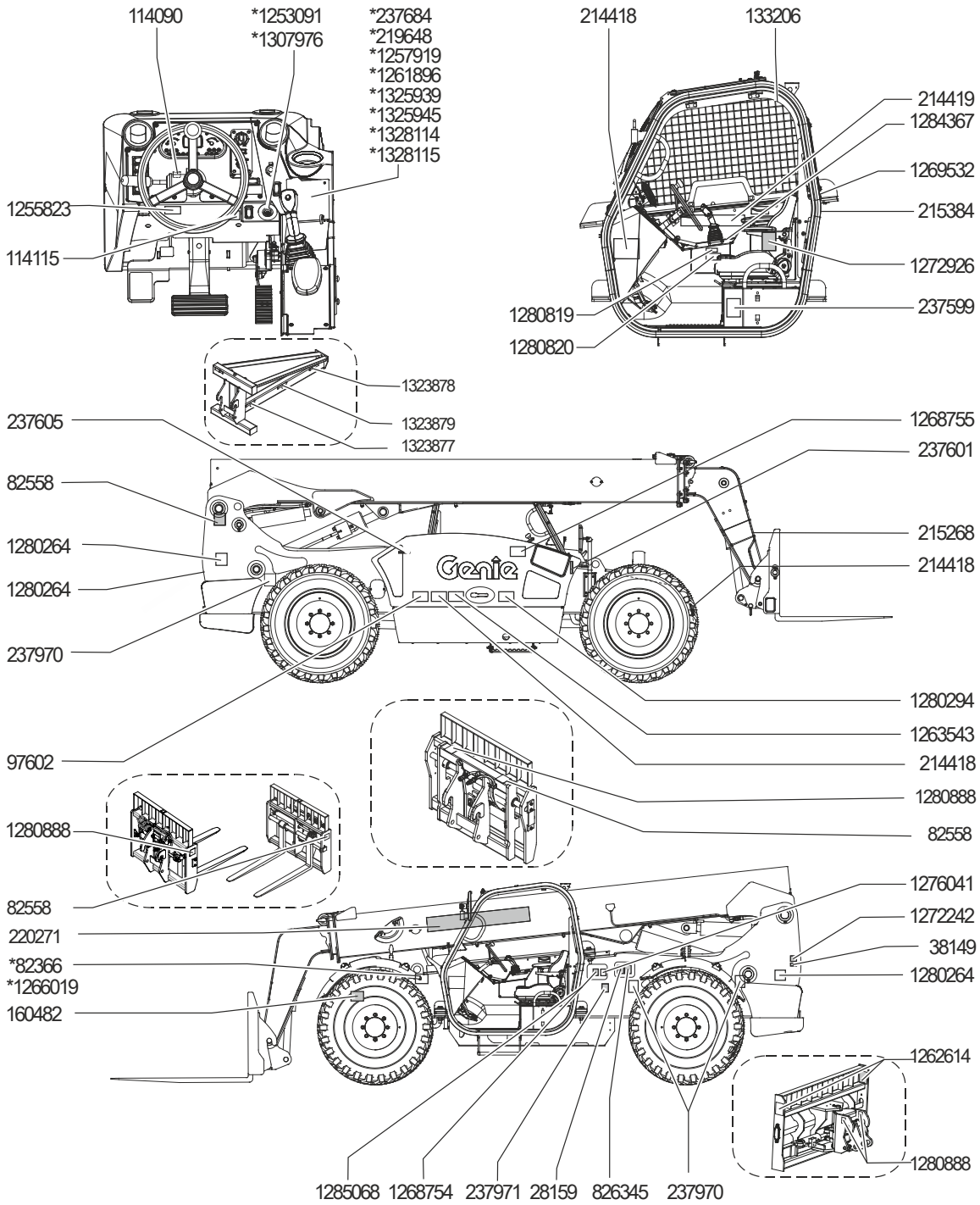

Inspections

Inspection for Decals with Symbols

Determine whether the decals on your machine have words or symbols. Use the appropriate inspection to verify that all decals are legible and in place.

Part No.	Decal Description	Qty
28159	Label – Diesel	1
82366	Label – Chevron Rando*	1
82560	Label – Skin Injection Hazard	2
114090	Label – Transmission Control	1
114115	Label – Steer Model Selector	1
133206	Label – Emergency Exit	1
160482	Label – Transport and Lifting	1
215644	Label – Crush Hazard, Tires	3
215645	Label – Explosion/Burn Hazard	1
215646	Label – 2 Decal Combination	3
215647	Label – 6 Decal Combination	1
215648	Label – Fall Hazard	1
219648	Label – Load Chart, Rotate Carriage*	1
220271	Label – Boom Lettering	1
237684	Label - Load Chart, Standard Carriage*	1
237721	Label – Bodily Injury Hazard	1
237722	Label – Explosion/Burn Hazard	1
237726	Label – Burn Hazard, Hot Components	1
1253091	Label – Key Ignition	1
1255823	Label – 3-speed Transmission	1
1257919	Label – Load Chart, Quick Attach Lifting Point*	1
1261896	Label – Load Chart, Swing*	1

Part No.	Decal Description	Qty
1262615	Label – Tip-over, Swing Carriage	2
1263542	Label – Compartment Access	1
1266019	Label – Shell Tellus*	1
1268754	Label – DEF Fill	1
1268755	Serial Plate	1
1269532	Label – Exterior Emergency Exit	1
1272242	Label – Machine Registration/Owner Transfer	1
1272926	Label – Fuse and Relay Panel	1
1276041	Label – Fill Level, Tank, 20 gal	1
1284367	Label – Electronic Controller	1
1285069	Label – Safety Chock	1
1286018	Label – Crush Hazard, Moving Machine	1
1286020	Label – Burn Hazard	3
1286022	Label – Crush Hazard, Moving Parts	2
1304217	Label – Explosion Hazard	1
1307976	Decal – Switch, Ignition, 3-Position*	1
1323877	Decal – 4000 LBS Cap	1
1323878	Decal – 2000 LBS Cap	1
1323879	Decal – 3000 LBS Cap	1
1325939	Label – Load Chart, GTH-844 Truss Boom*	1
1325945	Label – Load Chart, GTH-844 Bucket*	1
1328114	Label – Load Chart, GTH-844 Side Shift*	1
1328115	Label – Load Chart, GTH-844 Fork Positioner*	1

* These decals are model, option or configuration specific.

Inspections

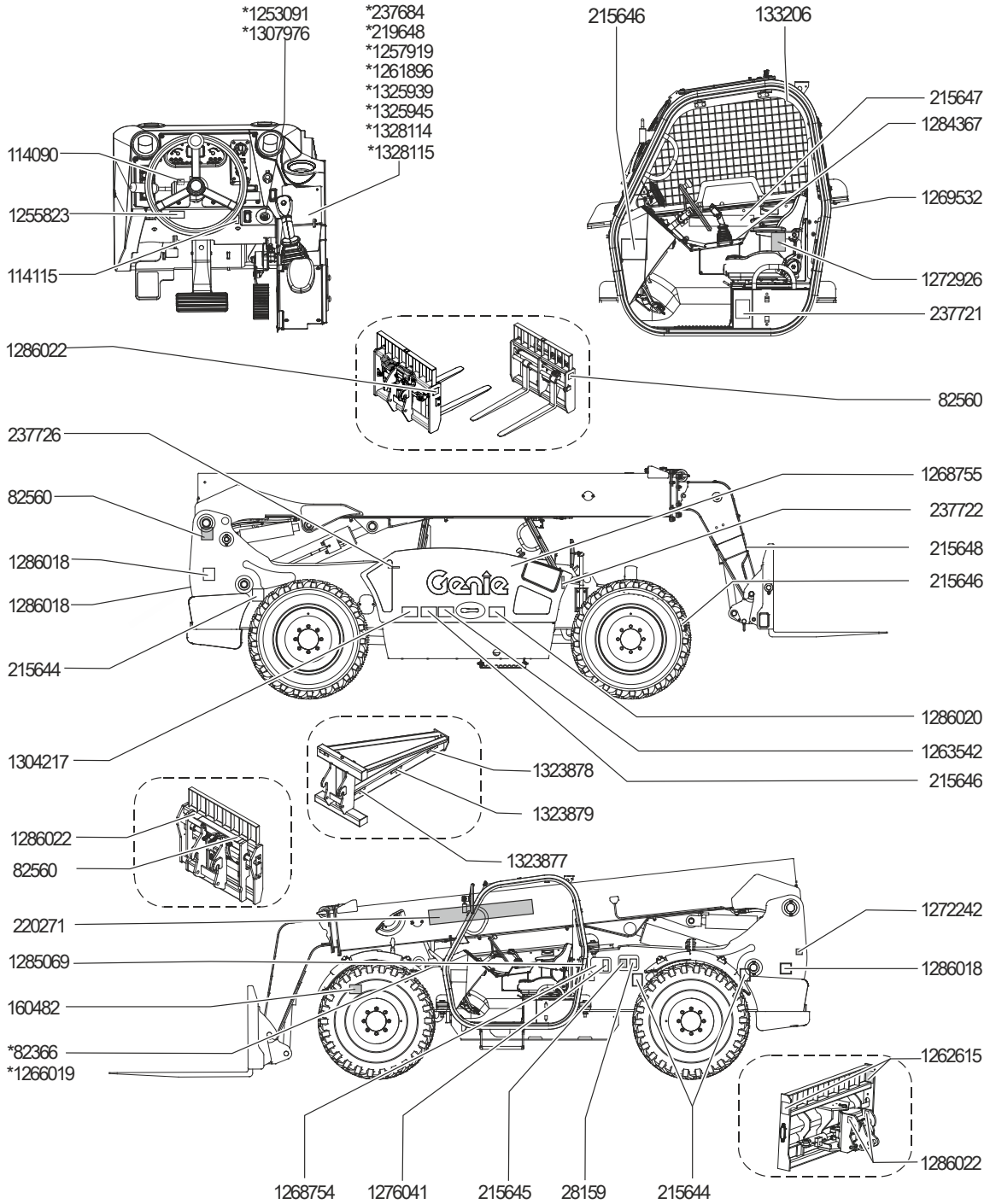

Operating Instructions



Do Not Operate Unless:

- You learn and practice the principles of safe machine operation contained in this operator's manual.
 - 1 Avoid hazardous situations.
 - 2 Always perform a pre-operation inspection.
 - 3 Always perform function tests prior to use.
 - 4 Inspect the workplace.
 - 5 Only use the machine as it was intended.**

Fundamentals

The Operating Instructions section provides instructions for each aspect of machine operation. It is the operator's responsibility to follow all the safety rules and instructions in the operator's, safety and responsibilities manuals.

A variable reach rough terrain forklift truck is defined as a wheeled type truck designated primarily as a fork truck with a pivoted boom, which may be equipped with attachments for lifting material. Using it for any other use is unsafe and dangerous.

Only trained and authorized personnel should be permitted to operate a machine. If more than one operator is expected to use a machine at different times in the same work shift, they must all be qualified operators and are all expected to follow all safety rules and instructions in the operator's, safety and responsibilities manuals. That means every new operator should perform a pre-operation inspection, function tests, and a workplace inspection before using the machine.

Operating Instructions

Parking Brake

Use the parking brake switch to apply the parking brake before raising the boom or leaving the machine.

Push the top of the rocker switch to turn the parking brake on.

Push the bottom of the switch to turn the parking brake off.

Brake Pedal

Use the brake pedal to control the machine speed and to stop the machine motion.

Push and hold the brake pedal to stop the machine.

Push and release the brake pedal to control the machine speed.

Battery Disconnect Switch (if equipped)

The battery disconnect switch is located on Inside the engine compartment, next to the battery.

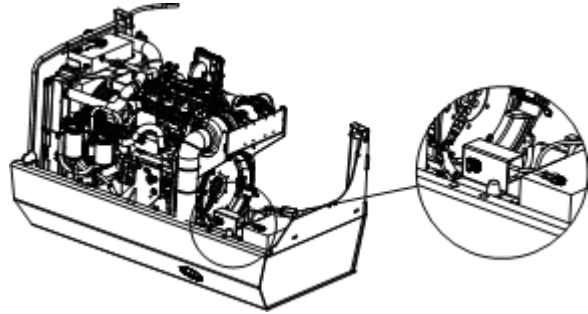

- 1 To activate the electrical system, insert the battery disconnect key and turn the key clockwise 90 degrees to the on position.
- 2 To deactivate the electrical system, turn the key counterclockwise 90 degrees to the off position.

▲ The battery disconnect switch must never be disabled while the engine is running.

Note: When servicing the machine or leaving the machine for a long period of time, turn the battery disconnect to the off position and remove the key.

Operating Instructions

Starting the Engine

- 1 Be sure the parking brake is set and the transmission control lever is in the neutral position.
- 2 Insert the key in the ignition switch.
- 3 Turn the key until the engine starts.

If the engine fails to start after 30 seconds of cranking, determine the cause and repair any malfunction. Wait 120 seconds before trying to start again.

Starting in Cold Condition

In cold conditions, 20°F/-6°C and below, warm the engine for 5 minutes before operating to prevent hydraulic system damage.

In extreme cold conditions, 0°F/-18°C and below, machines should be equipped with optional cold start kits. Attempting to start the engine when temperatures are below 0°F/-18°C may require the use of a booster battery.

Steer Select

Always position all wheels in line with the machine before switching the steering mode.

Do not realign the wheels while driving.

Steer selector switch

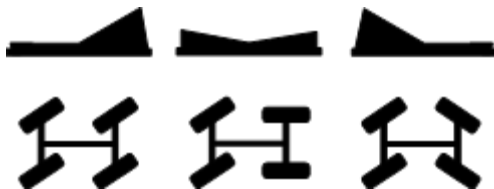

Emergency Exit (if equipped)

Rotate each retaining lever and push out the window.

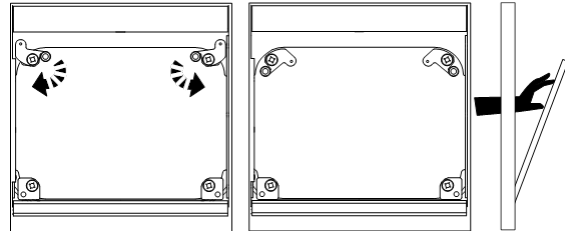

Exterior Emergency Exit (Safe T Punch) (if equipped)

Only install this device on tempered glass 0.15-0.24 in/4-6 mm thick.

- 1 Twist off the plastic security strip.
- 2 Hit the center of the punch with force. Repeat hitting punch until glass breaks.



- 3 Clear away window debris.

Operating Instructions

Fire Extinguisher

To operate an extinguisher:

- 1 Pull the pin
- 2 Aim nozzle at base of fire
- 3 Squeeze the handle
- 4 Sweep nozzle side to side

Transmission Control

Use the transmission control lever to control the speed and direction of machine travel.

Step on the service brake pedal before putting the transmission into gear.

To drive forward, move the transmission control lever up and forwards.

To drive in reverse, move the transmission control lever up and backwards.

To return to neutral, move the transmission control lever to the center position.

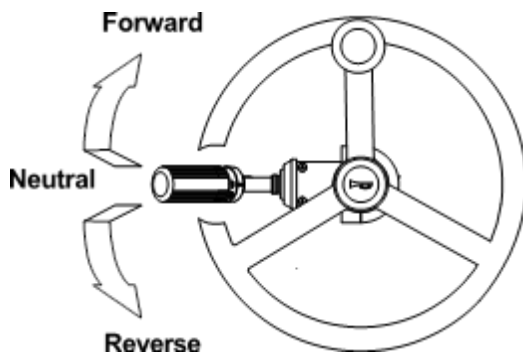

The transmission control lever also controls the transmission speed.

To choose a lower speed, rotate the control lever clockwise.

To choose a higher speed, rotate the control lever counterclockwise.

Models with 3-speed transmission

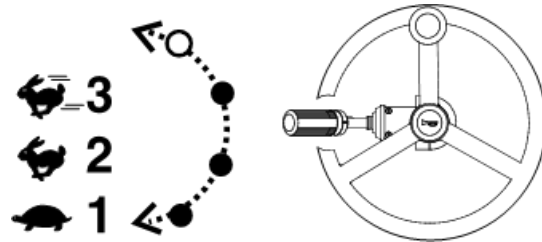

Come to a complete stop before shifting the transmission from forward to reverse. The transmission control lever must be in 1st or 2nd gear only.

Forward / 1st gear: Low speed / high torque

Forward / 2nd gear: Medium speed / medium torque

Forward / 3rd gear: High speed / low torque

Operating Instructions

Models with 2-speed transmission

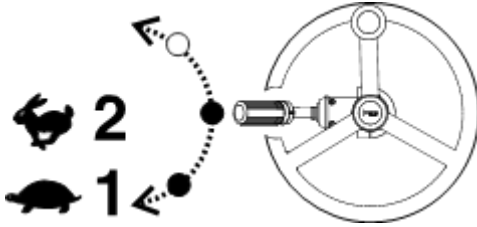

Come to a complete stop before shifting the transmission from forward to reverse. The transmission control lever must be in 1st or 2nd gear only.

Forward / 1st gear: Low speed / high torque

Forward / 2nd gear: Medium speed / medium torque

Axle Differential Lock

Use the axle differential lock switch to lock the axle differential and gain added traction in certain types of terrain such as sand, mud or snow.

Come to a complete stop before activating the axle differential lock. Do not lock the axle when the machine is moving. The axle differential lock should only be engaged with the machine stationary and the brake pedal fully depressed.

Push the button and hold it to activate the axle differential lock. Release the button to release the differential lock.

Frame Sway Control

Before raising the boom, the machine must be level.

- 1 Check the left to right level indicator. The left to right level indicator should be 0 degrees before raising the boom.
 - 2 If the machine is not level, use the frame sway control function to level the machine.
- ▲ Only use the frame sway control function if the boom angle indicator is at 0 degrees or less.

See Controller Movements section.

Transporting a Load

Always center the load on the forks. Position the load so that it is completely against the back of the fork frame. Fork length should always be at least 2/3 the load length.

The load should be kept as low to the ground as possible while traveling. Always move a loaded machine with the boom angle indicator at 0 degrees or less.

Tilt the forks back slightly to help keep the load secure.

Always bring the machine to a complete stop before applying the parking brake.

Operating Instructions

Raising and Placing a Load

Always center the load on the forks. Position the load so that it is completely against the back of the fork frame. Fork length should always be at least 2/3 the load length.

The load chart in the cab shows the operating limits of a properly maintained and operated machine. To use the load chart, the operator must know the weight of the load, its load center and how far out and up it is to be placed.

Refer to the Load Chart section of this manual for horizontal load centers exceeding 24 in/61 cm from the front of the fork face.

This machine has more than one load chart. Be sure you are using the load chart that corresponds to the attachment on the machine.

If you determine that the weight of the load cannot be placed at the height and angle you want, these options can be used:

- 1 Move the machine closer to the loading or pick point so that the weight of the load will meet the load chart specifications.
- 2 Divide the load into smaller pieces so that each piece meets the load chart specifications.
- 3 Obtain a larger machine capable of handling the load within specifications.

Placing the load

- 1 Travel to the desired work site and carefully stop the machine.
- 2 Put the transmission in neutral.
- 3 Apply the parking brake.
- 4 Level the frame, if the left to right level indicator or the front to back level indicator is not at 0 degrees.
- 5 Gradually move the controller to raise and extend the boom to the required height.

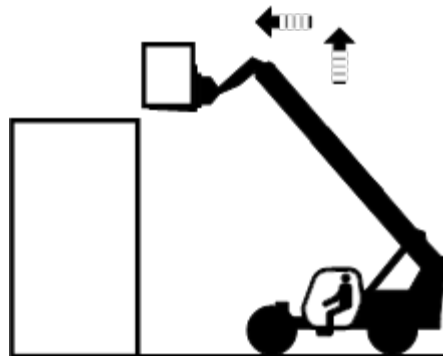
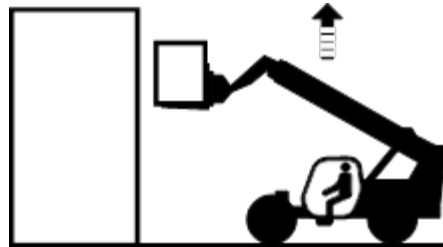

Operating Instructions

- 6 Gradually move the controller to lower and extend the boom into final position. Lower the load until the weight is completely off the forks. Do not apply a downward force with the forks.

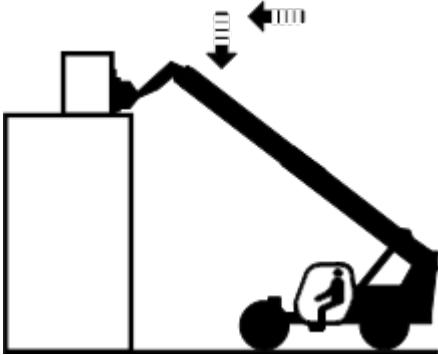

- 8 When the forks are clear of the load and the structure, the boom can be lowered and retracted.

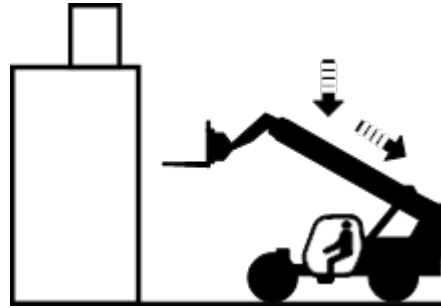

- 7 Gradually move the controller to raise and retract the boom. This will bring the forks out of the load.

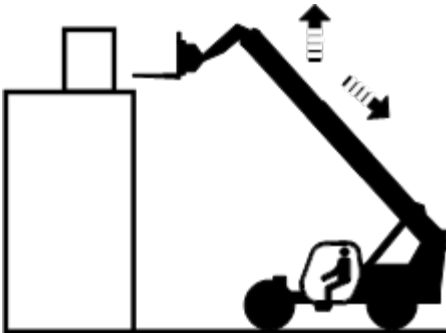

Operating Instructions

Controller movements – Electronic Control Handle

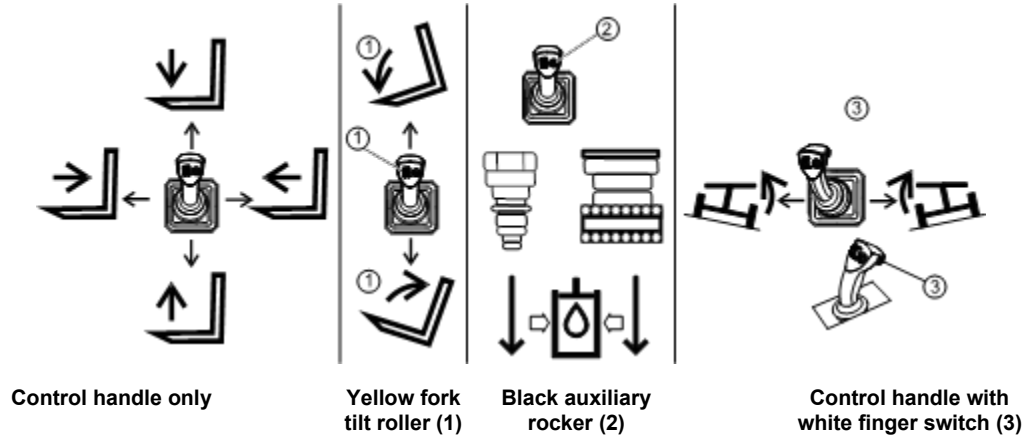

Operating Instructions

Rear Axle Lock

If the boom is raised above 55°, the transmission will shift to neutral and the frame sway function will not operate.

Boom and fork functions continue to operate.

To unlock the rear axle and to operate the frame sway function, lower the boom. When the boom is at or below 0°, the frame sway function will operate.

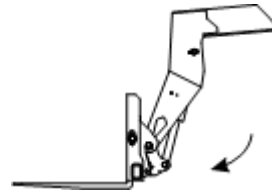

Tilt the forks back to pivot the quick attach into the attachment.

Insert the quick attach lock pin all the way through the attachment and be sure the quick attach lock lever is secured in the notch on the pin.

Quick Attach Instructions

Remove the quick attach lock pin.



Tilt the forks forward to pivot the quick attach connector back.

Position the boom so that the quick attach pin on the boom is below and centered between the hooks on the attachment.

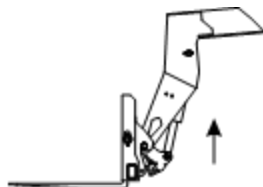

Raise the boom until the pin is secured in the hooks on the attachment.

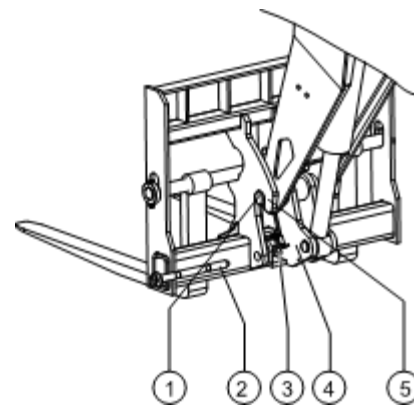

- 1 quick attach pin
- 2 quick attach lock pin
- 3 quick attach lock lever
- 4 quick attach connector
- 5 attachment hooks

Engine Condition Indicator

If the engine diagnostic display indicates an engine fault, contact service personnel.

Operating Instructions

Engine Display Information

Deutz engine (if equipped, only for 120HP option)

DEF light on: DEF level is low.



DEF light flashing: DEF level is very low.



DEF light on and check engine light on: tag and remove machine from service. contact service personnel. When light is on, torque and engine speed may be reduced.



Engine emissions standstill (regeneration) indicator light flashing (slow flash): perform SCR cleaning operation.



Engine emissions standstill (regeneration) indicator light on: SCR cleaning operation running.



Engine emissions (regeneration) indicator light flashing (fast flash): contact service personnel.



Engine emissions standstill (regeneration) disabled: contact service personnel.



Engine emissions exhaust temperature high/standstill (regeneration) active. If standstill has not been activated, the exhaust gas temperature exceeds maximum allowed value: contact service personnel



SCR cleaning operation

1 Be sure the machine is parked on a flat, level surface. Lower and retract the mast.

Do not operate the machine while the SCR cleaning operation is running.

2 Be sure the engine is warm. Set the parking brake. Put the transmission in neutral.

3 Locate the SCR cleaning operation switch on the dash.

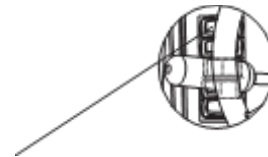

SCR cleaning operation switch

4 Press the right side of the switch. The cleaning operation will run automatically and will take approximately 35 minutes.

5 Return the machine to service.

Operating Instructions

Inactivity at Low Temperature

In case of inactivity of the machine at low temperature, make sure to store it with the boom fully retracted in order to avoid any ice accretion on its upper surface.

In case of ice accretion on the upper surface of the boom, make sure to remove it with an ice scrapper before using the machine.

Jump Starting the Machine

Jump starting at the battery or battery replacement is required when the battery is discharged to the point where the battery will not crank the starter.

Never jump start the machine directly to the starter or the starter solenoid. Serious injury or death could result from the machine moving forward or backward.

To avoid personal injury when jump starting with another machine, be certain that the machines are not touching.

Never jump start a frozen battery as it will explode.

Keep sparks and flames away from the battery. Lead acid batteries generate explosive gases when charging. Wear safety glasses when working near batteries.

The booster battery must be 12V. The machine used for jump starting must have a negative ground electrical system.

To jump start the machine

- 1 Connect the positive (+) jumper cable to the positive (+) post of the discharged battery.
- 2 Connect the other end of the same jumper cable to the positive (+) post of the booster battery.
- 3 Connect one end of the second jumper cable to the negative (-) post of the booster battery.
- 4 Make the final cable connection to the engine block or the furthest ground point away from the battery.
- 5 Turn the battery disconnect switch to the on position (if equipped)
- 6 Start the engine.

Operating Instructions

▲ Driving on a slope

When the machine is loaded, always travel with the load uphill. When the machine is unloaded, travel with the forks or attachment downhill.

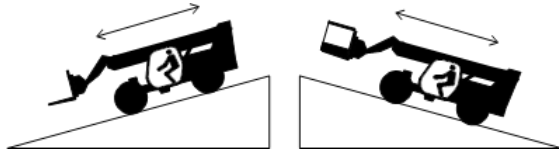

On steep terrain, drive only up and down hill, and always keep the machine in gear. Do not turn across slope when machine is traveling up or down a slope. To avoid overspeeding the engine and transmission when driving down slopes, downshift to a lower gear and use the service brake as necessary to maintain a slow speed.

Limit travel path and speed according to the condition of the ground surface, traction, slope, location of personnel and any other factors which may create a hazard. Never drive the machine unless the mast and equipment are in their proper travel position.

Whether a machine will tip over during dynamic machine operation involves many variables that need to be considered. Among these are pavement/ground conditions, stability and slope, as well as machine equipment, operator skill, load position, tire inflation, machine speed, etc.

Additionally, tip over of a machine is dependent in large part upon operator inputs such as the speed and smoothness of the operation as well as the position of the attachment and its load.

Construction sites and roads will frequently change slope from place to place, can be hard and soft, and change due to the construction activities and weather.

Operators should be properly trained and use their best judgment and experience to take the necessary precautions to prevent tip over. Operators must assess the jobsite variables and avoid exceeding the machine's (or operator's) capabilities for terrain and conditions.

Operating Instructions

▲ Rear Proximity Alarm (if equipped)

The system is designed to supplement other safety practices and systems such as signal person and mirrors, and is not intended to be used as the sole method of collision avoidance. It should be used in conjunction with established safety programs and procedures to augment the safe operation of the telehandler. The operator is always the first line of defense when safely operating the telehandler and should always use direct line of sight and indirect visual methods, like mirrors, to identify and avoid obstacles and collision hazards.

The system detects both moving and stationary objects in a pre-defined coverage area (see the specifications and chart in the back of this manual) and reports the distance of the closest object via visual range indicators and an audible signal to the operator.

The system can detect most objects within the detection zone. However, there are some instances where objects can go undetected. Obstacle size, shape, relative location, and composition are all factors determining if, when and where an object is detected. The system operates by transmitting a pulse of very low power electromagnetic energy. Any energy that strikes an object reflects a certain amount of this energy back to the sensor. If the returned energy is of sufficient magnitude, it is used to indicate object presence and determine the object's distance. While the system can resolve multiple objects, only the object closest to the vehicle is reported to the display since it represents the nearest collision hazard.

Always look in the direction of travel. When the rear proximity alarm sounds, bring the machine to a controlled stop and verify the location of the obstacle. Only proceed when the obstacle is clear of the travel path.

Display range indications illuminate to give a relative distance measurement to the closest detected object. LEDs operate from left to right, with a closer object resulting in more LEDs illuminated.

▲ Backup Camera Monitor (if equipped)

Monitors (if equipped) will switch to a full screen showing only the rear camera view when the vehicle is put into reverse. The sensor will be powered up by the reverse signal and give detection information. Object detection information is only available when the sensors are powered.

Operating Instructions

After Each Use

- 1 Select a safe parking location—firm level surface, clear of obstruction and traffic.
- 2 Retract and lower the boom to the stowed position and make sure forks are resting on the ground.
- 3 Move the transmission control lever to neutral.
- 4 Set the parking brake.
- 5 Turn the key switch to the off position and remove the key to secure from unauthorized use.

Machine Storage

Properly preparing and stowing the machine for extended storage will make it easier to put the machine back into service.

- 1 See After Each Use section for basic machine stowing instructions.
- 2 Store the machine in a dry and well-ventilated location. Be sure machine is clean and dry.
- 3 Perform a complete Pre-Operation Inspection.
Models with Engines: fill the fuel tank.
- 4 Refer to the Scheduled Maintenance section in the appropriate Service Manual, and complete each lubrication procedure.
- 5 Remove and store the battery.
- 6 Models with Engines: Refer to the OEM engine manual for additional extended storage procedures. As needed, start and run the engine for 10 minutes.

Transport and Lifting Instructions



Observe and Obey:

- Genie provides this securement information as a recommendation. Drivers are solely responsible for making sure machines are properly secured and the correct trailer is selected pursuant to US Department of Transportation regulations, other localized regulations, and their company policy.
 - Genie customers needing to containerize any lift or Genie product should source a qualified freight forwarder with expertise in preparing, loading and securing construction and lifting equipment for international shipment.
 - Only qualified operators should move the machine on or off the truck.
 - The transport vehicle must be parked on a level surface.
 - The transport vehicle must be secured to prevent rolling while the machine is being loaded.
- Before loading for transport, make sure the deck, ramps and machine tires are free of mud, snow and ice. Failure to do so could cause the machine to slide.
 - Be sure the vehicle capacity, loading surfaces and chains or straps are sufficient to withstand the machine weight. Genie telehandlers are very heavy relative to their size. See the serial label for the machine weight. See the Inspections section for the serial label location.

Transport and Lifting Instructions

Securing to Truck or Trailer for Transit

Turn the key switch to the off position and remove the key before transporting.

Inspect the entire machine for loose or unsecured items.

Be sure the door and the door windows are latched and secured (if equipped).

Prior to loading, level the telehandler and retract the boom.

Use a spotter to load and unload the telehandler. Keep the boom as low as possible when loading and unloading.

Set the parking brake.

Securing the Chassis

Use chains of ample load capacity.

Use a minimum of 6 chains. There are 6 tie down points on the chassis, two in the front and two on each side of the machine.

Fully lower the forks or attachment onto the truck bed. Secure the forks or attachment with a suitable strap or chain to prevent movement.

Adjust the rigging to prevent damage to the chains.

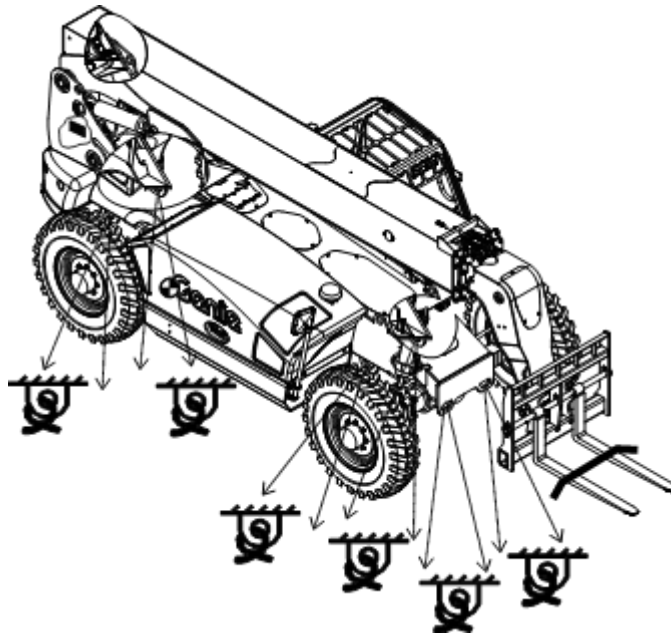

Transport and Lifting Instructions



Observe and Obey:

- ☑ Only qualified riggers should rig the machine.
- ☑ Only certified crane operators should lift the machine and only in accordance with the applicable crane regulations.
- ☑ Be sure the crane capacity, loading surfaces and straps or lines are sufficient to withstand the machine weight. See the serial label for the machine weight.

Lifting Instructions

Fully lower and retract the boom.

Determine the center of gravity of your machine using the picture on this page.

Remove all loose items on the machine.

Attach the rigging only to the designated lifting points on the machine.

Adjust the rigging to prevent damage to the machine and to keep the machine level.

Center of gravity

1	Y Axis	44 in 1.1 m
2	X Axis	102 in 2.6 m

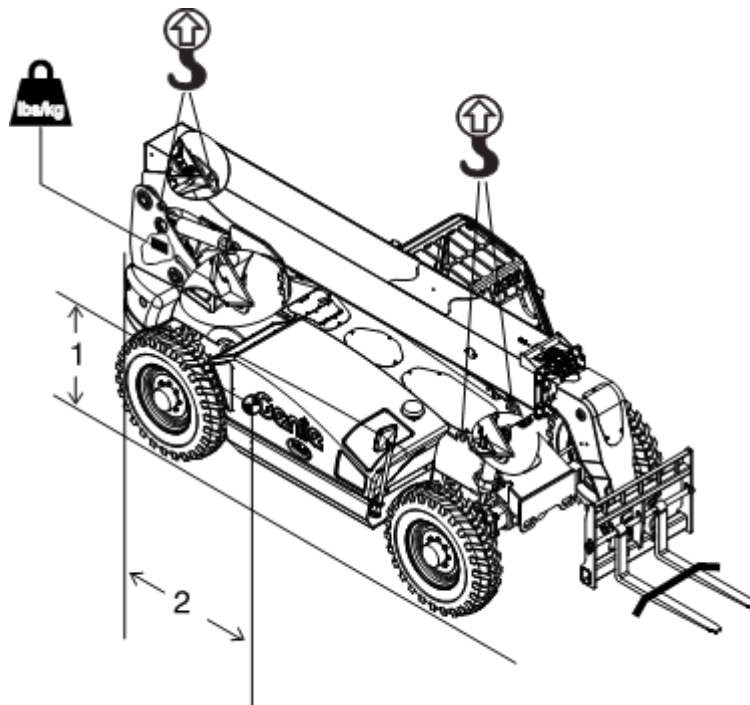

Maintenance



Observe and Obey:

- ☑ Only routine maintenance items specified in this manual shall be performed by the operator.
- ☑ Scheduled maintenance inspections shall be completed by qualified service technicians, according to the manufacturer's specifications and the requirements specified in the responsibilities manual.

Maintenance Symbols Legend

The following symbols have been used in this manual to help communicate the intent of the instructions. When one or more of the symbols appear at the beginning of a maintenance procedure, it conveys the meaning below.



Indicates that tools will be required to perform this procedure.



Indicates that new parts will be required to perform this procedure.



Indicates that a cold engine is required before performing this procedure.

Check the Engine Oil Level



Maintaining the proper engine oil level is essential to good engine performance and service life. Operating the machine with an improper oil level can damage engine components.

Note: Check the oil level with the engine off.

- 1 Check the oil level dipstick. Add oil as needed.

Perkins 1104D-E44T Engine

Oil type	15W-40
----------	--------

Perkins 854E-E34TA Engine

Oil type	API CJ-4 15W-40 Low Ash Oil
----------	--------------------------------

Perkins 854F-E34TA Engine

Oil type	API CJ-4 15W-40 Low Ash Oil
----------	--------------------------------

Deutz TCD 3.6 L4 Tier 3 Engine

Oil type	15W-40
----------	--------

Deutz TCD 3.6 L4 Tier 4i and Tier 4f Engine

Oil type	API CJ-4 15W-40 Low Ash Oil
----------	--------------------------------

Maintenance

Check the Transmission Oil Level



Maintaining the proper transmission oil level is essential to good transmission performance and service life. Operating the machine with an improper oil level can damage transmission components.

Note: Check the oil level dipstick with the engine running at idle (1000 RPM) and the oil at running temperature (180-200 F). Add oil as needed.

- 1 Check the oil level dipstick. Add oil as needed.

Dana Transmission T12000

Oil type	Chevron Ursa 10W
----------	------------------

Diesel Fuel Requirements



Satisfactory engine performance is dependent on the use of a good quality fuel. The use of a good quality fuel will give the following result: long engine life and acceptable exhaust emissions levels.

Minimum diesel fuel requirements for each engine are listed below.

Perkins 1104D-E44T Engine

Fuel Type	Low Sulfur Diesel (LSD)
-----------	-------------------------

Perkins 854E-E34TA Engine

Fuel Type	Ultra Low Sulfur Diesel (ULSD)
-----------	--------------------------------

Perkins 854F-E34TA Engine

Fuel Type	Ultra Low Sulfur Diesel (ULSD)
-----------	--------------------------------

Deutz TCD 3.6 L4 Tier 3 Engine

Fuel Type	Low Sulfur Diesel (LSD)
-----------	-------------------------

Deutz TCD 3.6 L4 Tier 4i and Tier 4f Engine

Fuel Type	Ultra Low Sulfur Diesel (ULSD)
-----------	--------------------------------

Maintenance

Check the Hydraulic Oil Level



Maintaining the hydraulic oil at the proper level is essential to machine operation. Improper hydraulic oil levels can damage hydraulic components. Daily checks allow the inspector to identify changes in oil level that might indicate the presence of hydraulic system problems.

- 1 Be sure that the engine is off, the frame is level and the boom is in the stowed position.
- 2 Visually inspect the sight gauge located on the side of the hydraulic oil tank.
- ⊙ Result: The hydraulic oil level should be at the fill mark on the side gauge.
- 3 Add oil as needed. Do not overfill.

Hydraulic oil specifications

Hydraulic oil type	Chevron Rando HD equivalent
--------------------	-----------------------------

Check the Batteries



Proper battery condition is essential to good machine performance and operational safety. Improper fluid levels or damaged cables and connections can result in component damage and hazardous conditions.

- ▲ Electrocution hazard. Contact with hot or live circuits may result in death or serious injury. Remove all rings, watches and other jewelry.
 - ▲ Bodily injury hazard. Batteries contain acid. Avoid spilling or contacting battery acid. Neutralize battery acid spills with baking soda and water.
- 1 Put on protective clothing and eye wear.
 - 2 Be sure that the battery and the battery disconnect switch cable connections are tight and free of corrosion.
 - 3 Be sure that the battery hold-down brackets are in place and secure.

Note: Adding terminal protectors and a corrosion preventative sealant will help eliminate the corrosion on the battery terminals and cables.

Maintenance

Check Mirrors and Rear Proximity Alarm System



Maintaining the indirect visual aids is essential to workplace visibility.

- 1 Visually inspect all mirrors, the steering column mounted LED module with alarm and rear mounted proximity sensor (if equipped) to ensure they are working properly and clean and free from debris.

Check the Engine Coolant Level – Liquid Cooled Models



Maintaining the engine coolant at the proper level is essential to engine service life. Improper coolant level will affect the engine's cooling capability and damage engine components. Daily checks will allow the inspector to identify changes in coolant level that might indicate cooling system problems.

Perkins Engines:

- 1 Check the fluid level in the radiator.
- ⊙ Result: The fluid level should be at the bottom of the filler neck.
 - ⚠ Bodily Injury Hazard. Fluids in the radiator are under pressure and extremely hot. Use caution when removing cap and adding fluids.

Deutz Engines:

- 1 Check the fluid level in the sight glass located on the radiator expansion tank.
- ⊙ Result: The fluid level should be at the half way mark of the sight glass when the engine is cold.

Coolant Specification

Perkins and Deutz engines	Extended Life Coolant (ELC)
---------------------------	-----------------------------

Maintenance

Check the Tire Pressure



- ▲ Tip-over hazard. An over-inflated tire can explode which may compromise machine stability and cause the machine to tip over.
- ▲ Tip-over hazard. The use of temporary flat tire repair products may lead to tire failure which could compromise machine stability and cause the machine to tip over.
- ▲ Bodily injury hazard. An over-inflated tire can explode and may cause death or serious injury.

Note: This procedure does not need to be performed on machines equipped with foam-filled tires.

- 1 Check each tire with an air pressure gauge. Add air as needed.

Tire pressure	62 psi	4.3 bar
----------------------	--------	---------

Check DEF Level (if equipped)



Maintaining DEF (diesel exhaust fluid) at the proper level is essential to machine operation. Operators should monitor the indicator light during use to identify changes in DEF level that might indicate the presence of system problems. Add DEF each time fuel is added or add DEF when the indicator light is on.

Always use DEF fluid from a fresh, sealed container. DEF fluid can degrade if left in an unsealed container, or if it is not used by the expiration date.

- 1 Be sure that the engine is off, the frame is level and the boom is in the stowed position.
- 2 Turn the key switch to the on position.
- 3 Visually inspect the DEF level on the LCD screen.

Models with Four Button Panel: Press the UP button to display the DEF level bar.

- ⊙ Result: The DEF fluid level should be within the green area on the DEF level.
- 4 Add DEF as needed. Do not overfill.

DEF specifications

DEF type	ISO 22241-1
----------	-------------

Maintenance

Drain the Fuel/Water Separator



Proper maintenance of the fuel filter/water separator is essential for good engine performance. Failure to perform this procedure can lead to poor engine performance and/or hard starting, and continued use may result in component damage. Extremely dirty conditions may require this procedure be performed more often.

Explosion and fire hazard. Engine fuels are combustible. Perform this procedure in an open, well-ventilated area away from heaters, sparks, flames and lighted tobacco. Always have an approved fire extinguisher within easy reach.

Note: Perform this procedure with the engine off.

- 1 Locate the fuel filter/water separator and loosen the vent plug located on the fuel filter/water separator head.

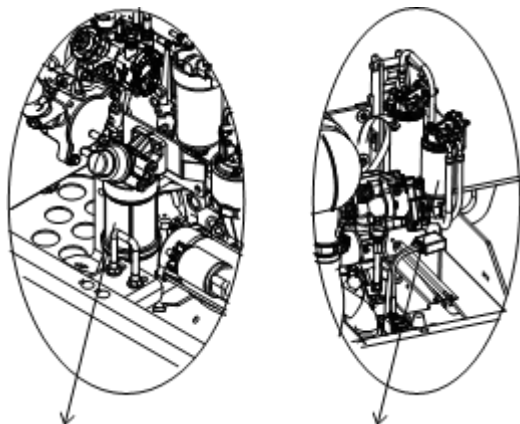

Perkins:
fuel/water
separator

Deutz: fuel/water separator

- 2 Loosen the drain plug located at the bottom of the bowl. Allow the water to drain into a suitable container until fuel starts to come out. Immediately tighten the drain plug.
- 3 Tighten the vent plug and clean up any spills or wet surfaces.
- 4 Tighten the drain plug. Torque the plug to 14.2 in-lbs / 1.6Nm.

Safety Check for Cylinder Rod



Before carrying out any maintenance or repair procedures under a raised boom, install the provided safety check.

CAUTION

Crushing hazard The cylinder could fall if not properly supported.

- 1 Using a 9/16 combination wrench, remove the two fasteners securing the safety check (A) mounted on chassis side plate behind the cab and remove the check.

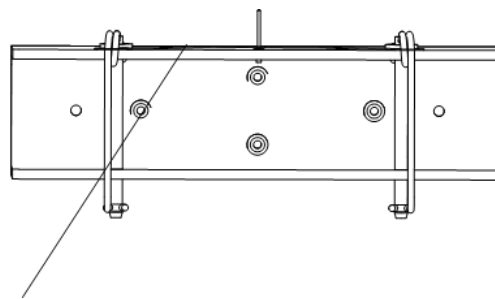

Safety check

- 2 Remove the spring clips securing the pins to the check, and remove the pins from the check.

Maintenance

- 3 Install the safety chock on the lifting cylinder rod. Properly position the chock onto the cylinder as show in the figures below. Secure the chock on to the cylinder using the lock pins and the spring clips in step 1.

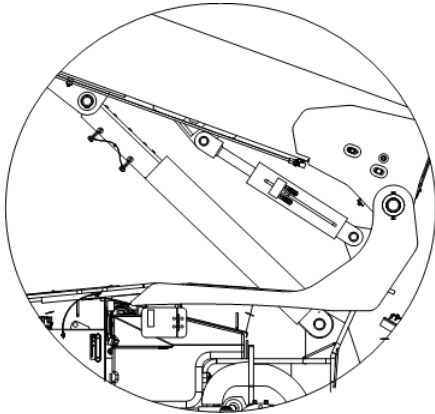

Scheduled Maintenance

Maintenance performed quarterly, annually and every two years must be completed by a person trained and qualified to perform maintenance on this machine according to the procedures found in the service manual for this machine.

Machines that have been out of service for more than three months must receive the quarterly inspection before they are put back into service.

Obey all local and governmental regulations regarding the disposal and decommissioning of the machine at the end of its lifetime. Refer to the appropriate Genie service manual for additional information.

Attachments

⚠ Work Platform Hazards

Work Area Safety

The telehandler shall not be used to lift people unless there is no other practical option. If a telehandler must be used to lift people, the following precautions for the protection of occupants shall be taken.

Use only a Genie approved personnel work platform which complies with the design requirements of ANSI/ITSDF B56.6.



Do not lift personnel with a telehandler unless it is equipped with an approved work platform.

The user or employer and the operator shall further investigate, and comply with, all applicable jobsite, local, state, provincial, or federal rules, regulations, and standards related to the use of the telehandler with a work platform.

Read, understand and obey all warnings and instructions provided with the attachment that is approved for elevating personnel.

The operator and the platform occupants must be instructed regarding the specific hazards associated with using the telehandler with the work platform, and utilize all means, including those provided by the user or employer, to avoid them.

Always perform a pre-operation inspection of the platform, per the manufacturer's instructions, prior to use.

If damage or any unauthorized variation from factory delivered condition is discovered, the platform must be tagged and removed from service.

Do not modify the platform without written approval by Genie and the platform manufacturer.

Do not use the telehandler with a work platform attached for any purpose other than positioning personnel with their tools, materials and equipment.

Provide overhead protection as required by the operating conditions.

Platform Occupant

Fall Protection

Personal fall protection equipment (PFPE) is required for all occupants of the work platform.

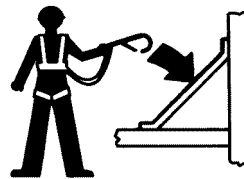

Occupants must wear a safety belt or harness in accordance with governmental regulations. Attach the lanyard to the anchor provided in the platform.

All PFPE must comply with applicable governmental regulations, and must be inspected and used in accordance with the PFPE manufacturer's instructions.

Attachments

Occupying the Platform

Do not carry materials directly on platform railing unless approved by Genie.

Be certain that materials and tools are protected from falling out of the platform.



Be aware of crushing hazards when grasping the platform guard rail. During movement of the platform, occupants must keep all body parts inside the platform railing.



Do not sit, stand, or climb on the platform guard rails. Maintain a firm footing on the platform floor at all times.

Do not enter or exit the platform unless the machine is in the stowed position and the platform is at ground level.

Occupants shall not climb on any part of the telehandler in attempting to enter and exit the platform.



Do not climb down from the platform when raised.

Do not place or attach overhanging loads to any part of this machine or platform.



Do not place ladders or scaffolds in the platform or against any part of this machine.

Do not tie the boom or platform to adjacent structures.

Do not place loads outside the platform perimeter.

Do not transport tools and materials unless they are evenly distributed and can be safely handled by person(s) in the platform.

Keep the platform floor clear of debris.

Never use ladders, boxes, steps, planks or similar items on the platform to provide additional reach.

Be certain that required personnel fall protection devices, such as guard rails and full body harness with lanyard, are in place and properly used.

Use the hand rails to maintain balance while the platform is in motion.

Do not increase the surface area of the platform or the load. Increasing the area exposed to the wind will decrease machine stability.

Attachments

Telehandler Operation

Be certain that the platform is securely attached to the telehandler, lifting carriage and forks.

Be certain that the lifting carriage and forks are secured to prevent them from pivoting freely.



Do not drive the telehandler when occupants are in the platform.

Always fully lower the platform and have occupants leave the platform before driving the telehandler.

Before elevating personnel, the area shall be marked to warn of work by elevated personnel.

Prior to lifting personnel, platform occupants and telehandler operator must establish a means of communication for positioning of the platform.

Be sure that operators of other overhead and floor level machines are aware of the machine's presence.

Lifting Personnel

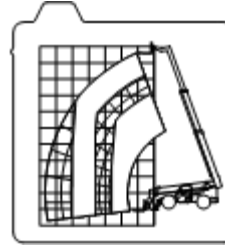

Occupants, equipment and materials shall not exceed the maximum platform capacity. Distribute loads evenly on the platform floor.

The combined weight of the platform, load, and personnel shall not exceed one-third of the capacity at the related load center position (24 inches/60 cm) as indicated on the load charts of the telehandler on which the platform is used.

Be certain that the path of platform travel is clear of hazards such as storage racks, scaffolds, overhead obstructions, and electrical wires.



Do not level the machine with the frame sway function when the platform is occupied.



Be certain that the platform is horizontal before lifting, and do not tilt the platform forward or backward when the occupied platform is elevated.

When equipped, always lower the stabilizers prior to raising personnel.

Attachments

Keep bystanders away while operating.

Do not place boom or platform against any structure to steady the platform or to support the structure.

Do not use the controls to free a platform that is caught, snagged or otherwise prevented from normal motion by an adjacent structure. All personnel must be removed from the platform before attempting to free the platform using the controls.



Check the work area for overhead obstructions or other possible hazards.

Be certain that the path of platform travel is clear of hazards, such as storage racks, scaffolds, overhead obstructions, and electrical wires.

Do not allow personnel or bystanders to tamper with or operate the machine from the cab when occupants are in the platform except in an emergency or when directed by the occupants.

Always lift and lower personnel smoothly and with caution, and only at their request.

Operating Instructions

Preparation and Setup

Read, understand and obey all jobsite, local, state, federal and provincial rules, standards and regulations as they pertain to the use of a telehandler mounted personnel work platform (In the USA and Canada, reference ANSI/ITSDF B56.6 and CSA B335).

If the personnel work platform is equipped with safety instructions, make sure a copy is placed in the cab as well as in the work platform, if it is equipped with a manual holder.

Cordon off the area to warn of work by elevated personnel. Keep the area under the platform free of personnel.

Be sure the telehandler is on a firm level surface capable of supporting all forces imposed by the machine.

Without personnel in the platform, perform a simulated lift with the designated signal person on the ground as a spotter, to assure adequate telehandler range and attachment clearances and that the telehandler lifting mechanism is operating smoothly.

Attachments

Installing and securing the platform

Center the platform on the telehandler.

Properly secure the platform to the telehandler according to the manufacturer's instructions.

Be sure that the forks supporting the platform are secured to prevent them from pivoting forward.

If mounted to a rotating attachment, center the rotation of the attachment and then deactivate its rotation capability.

Level the platform, both side to side (frame sway function) and front to rear (attachment tilt function).

Entering, occupying and exiting the platform

Use three-point contact when entering or exiting a work platform.

Only enter and exit the platform when it is at ground level.

Only enter and exit the platform at the designated entry and exit locations.

Close and secure the entry point gate or railing before signaling to be lifted.

Attach PFPE to the designated lanyard anchor.

Occupants should use the guardrail to help stabilize themselves during movement. Be aware of crushing hazards when grasping the platform guardrail.

Lifting and lowering the platform

Set the parking brake and place the transmission into neutral.

If equipped with stabilizers: Lower the stabilizers.

Only allow personnel to enter and exit the platform when it is at ground level.

Establish and maintain a means of communication with the occupants.

Only move the platform at the request of a single designated occupant. Never tilt the platform forward or backward, or attempt to level the machine when the platform is occupied.

Sound the horn to alert occupants prior to lifting or lowering the platform.

Move the platform slowly, smoothly and with caution.

Keep hands and feet clear of all controls other than those in use.

When the platform is occupied, the telehandler operator must remain seated in the cab with the occupants in direct line of sight.

Attachments

▲ Suspended Load Hazards

Work Area Safety

General Safety

Do not lift a suspended load without first understanding the local, state, federal, or provincial rules, standards and regulations related to the activity. In the USA requirements are set forth in ANSI/ITSDF B56.6 and OSHA 29 CFR 1926.1400-1442. Additional rules, standard and regulations may apply. Additional training may be required.

If a telehandler must be used to transport a suspended load, the following precautions for the protection of the operator shall be taken.

Read, understand and obey all warnings and instructions provided with the attachment that is approved for suspending loads.

Only properly designed, tested and approved attachments, designated lifting points, and lifting accessories should be used to support a suspended load.

The telehandler load charts are designed for loads where the load center is stationary. As a suspended load moves, the load center can change. As a result, extreme caution in transporting and lifting, or placing, the load must be observed to minimize the potential for the load to move.

A single shackle lifting point is rated for the maximum lifting capacity referenced on the load chart. It can be used as a single lift point, or both lifting points can be used to suspend a load. Never exceed the maximum capacity referenced in the load chart when using one or both lifting points.

Tip-over Hazards

Do not lift a suspended load without the proper and legible load capacity chart for the attachment/telehandler combination you are using.



Do not permit the load to swing freely. Always properly tether loads to restrict movement.

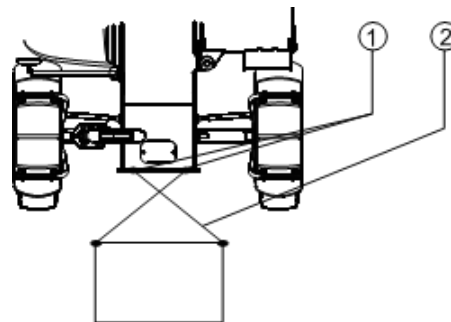

- 1 Tie-down points - GTH-636, GTH-844
- 2 Crossed tethers

Attachments

In addition to ground personnel, the two chassis tie-down points in the front of the machine can be used to help externally stabilize the load. Always cross the tethers to opposite sides of the load to minimize load movement. Driving across grades, sudden starts, stops, and turns can cause the load to swing and create a hazard if not externally stabilized.

Only use proper rigging, capable of withstanding the expected loads, to tether the load. Do not use tethers that are damaged. Always remove any tethers before placing a suspended load.

Always protect tethers from abrasion and damage.

Keep the boom retracted as much as practical.

Do not lift suspended loads when wind speeds can cause an unsafe situation.

All movements of the load must be accomplished gradually and at the slowest practical speed to prevent the load from swinging.

Keep the heavy part of the load closest to the attachment.

Never drag or pull a load sideways.

Only lift a load vertically; do not pull a load horizontally as it could cause excessive swinging of the load. The weight of all rigging (slings, shackles etc.) must be included as part of the load.

Identify the proper lifting points of the load, taking into consideration the center of gravity and load stability.

Identify the proper lifting points of the load, taking into consideration the center of gravity and load stability.

Do not attempt to use the telehandler frame-leveling to compensate for a swinging load or to adjust the load after it has been raised.

Do not try to move fixed or obstructed loads.

Do not leave the telehandler unattended with a suspended load.

Keep the boom and load as low as practical while maintaining visibility in the direction of travel. Do not exceed walking speed (2 mph/3.2 km/h) with a suspended load.

Start, travel, turn and stop slowly to prevent the load from becoming unstable or swinging.

Do not use any controls to re-position the load when traveling. Come to a gradual and complete stop before attempting to re-position the load.

Do not attempt to cross inclines as the load center will move towards the tipping line, thereby reducing stability.

Only climb or descend inclines with extreme care as the load center will move towards the tipping line, thereby reducing stability.

Do not park on a slope.

Fall Hazards

Do not lift or suspend personnel.

Attachments

Collision Hazards

Be sure that the load is clear of any adjacent obstacles before lifting.

When visibility is or could be obstructed, near or at the load placement, the operator shall use alternative or additional means to safely lift the load, such as a qualified signal person.

Signal persons must remain in constant communication (verbal or hand) and be in visual contact with the operator at all times.

Crush Hazards

Never allow the signal person to come between the suspended load and another object (such as the telehandler itself).

Falling Object Hazards

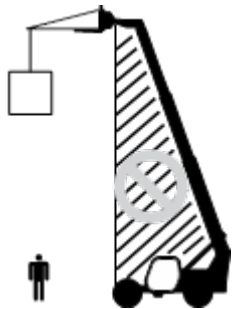

Do not raise the load into the fall zone shown.

Do not operate the machine while people are under the load or in the fall zone.

Do not suspend loads using slings or chains from the forks or fork carriage.

Avoid lifting double tiered loads.

Always watch for personnel who may walk under the load and warn them before they walk under the load.

Lifting a Suspended Load

Verify that landing point is level and can safely support the load.

Properly secure the attachment to the telehandler.

Level the frame on the telehandler.

Rig the load as outlined in OSHA 29 CFR 1926.1401, 1926.1404, 1926.1425, keeping the heaviest part of the load as close to the attachment as practical.

Tether the load to restrict movement.

Ask a signal person to assist with lifting the load if visibility will be obstructed at the point of operation.

Make sure that the signal person remains in constant communication and is in visual contact at all times.

With the boom retracted as far as practical, slowly and gradually raise the boom and load, making sure to keep the load and boom as low to the ground as practical.

Be sure that all boom and attachment movements are performed as slow as practical to avoid swinging of the load.

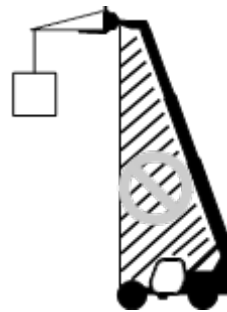

Attachments

Traveling

Be sure that the path of travel is level and capable of supporting the telehandler with its load.

Keep the boom, and load, as low as practical while maintaining visibility in the direction of travel.

Ask a signal person to assist with your travel if visibility will be obstructed in the direction of travel.

Crush or Collision Hazard. Make sure that the signal person remains in constant communication and be in visual contact at all times.

Only make adjustments to the load after bringing the telehandler to a complete stop.

Start, stop, travel and turn slowly to prevent the load from becoming unstable or swinging.

Do not travel faster than walking speed (<2 mph/3.2 km/h).

Placing the Load

Ask a signal person to assist with placing the load if visibility will be obstructed at the point of operation.

Make sure that the signal person remains in constant communication and be in visual contact at all times.

Come to a complete stop near the landing point.

If equipped with stabilizers: Lower the stabilizers.

Set the parking brake and place the transmission into neutral.

Slowly, and gradually, place the load over the landing point and lower the load until it is safely supported.

Once the load has been landed, continue to lower the boom until the rigging and tethers can be removed.

Signal Person (from 1926.1419)

Per OSHA CFR 1926.1419, a signal person is required when:

The point of operation, meaning the load travel or the area near or at load placement, is not in full view of the operator.

When the equipment is traveling, the view in the direction of travel is obstructed.



Due to site specific safety concerns, either the operator or the person handling the load determines that it is necessary.

Signal persons must remain in constant communication (verbal or hand) and be in visual contact with the operator at all times.

When using hand signals, follow the requirements set forth in OSHA CFR 1926.1419-1926.1422.

The hand signal chart below may be used in place of the Standard Method in Appendix A of Subpart CC of Part OSHA CFR 1926.

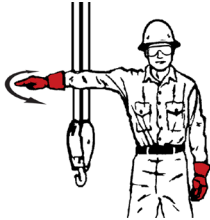
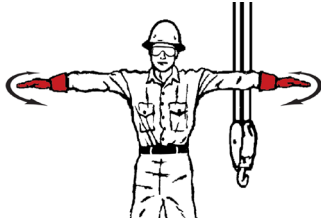
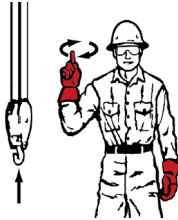
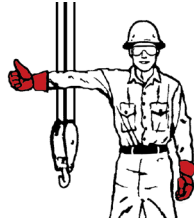
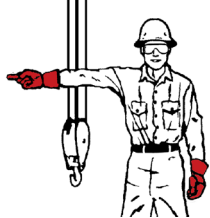
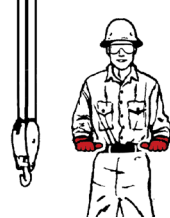
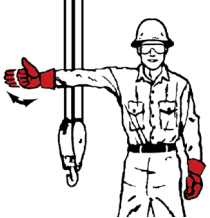
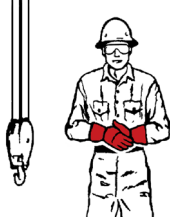
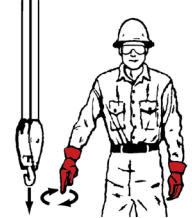
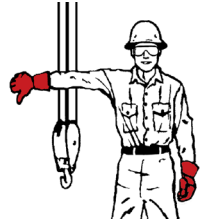
Attachments

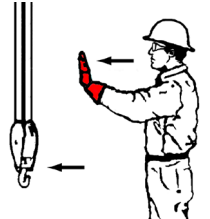
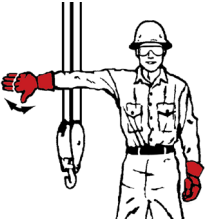
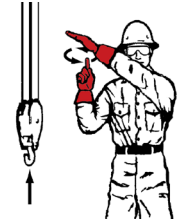
 <p>STOP. With arm extended horizontally to the side, palm down, arm is swung back and forth.</p>	 <p>EMERGENCY STOP. With both arms extended horizontally to the side, palms down, arms are swung back and forth.</p>		 <p>HOIST. With upper arm extended to the side, forearm and index finger pointing straight up, hand and finger make small circles.</p>	 <p>RAISE BOOM. With arm extended horizontally to the side, thumb points up with other fingers closed.</p>
 <p>SWING. With arm extended horizontally, index finger points in direction that boom is to swing.</p>	 <p>RETRACT TELESCOPING BOOM. With hands to the front at waist level, thumbs point at each other with other fingers closed.</p>	 <p>RAISE THE BOOM AND LOWER THE LOAD. With arm extended horizontally to the side and thumb pointing up, fingers open and close while load movement is desired.</p>	 <p>DOG EVERYTHING. Hands held together at waist level.</p>	 <p>LOWER. With arm and index finger pointing down, hand and finger make small circles.</p>
 <p>LOWER BOOM. With arm extended horizontally to the side, thumb points down with other fingers closed.</p>	 <p>EXTENDED TELESCOPING BOOM. With hands to the front at waist level, thumbs point outward with other fingers closed.</p>	 <p>TRAVEL/TOWER TRAVEL. With all fingers pointing up, arm is extended horizontally out and back to make a pushing motion in the direction of travel.</p>	 <p>LOWER THE BOOM AND RAISE THE LOAD. With arm extended horizontally to the side and thumb pointing down, fingers open and close while load movement is desired.</p>	 <p>MOVE SLOWLY. A hand is placed in front of the hand that is giving the action signal.</p>

Attachments

▲ Suspended Load Hazards

Rigger Requirements (from OSHA CFR 1926.404)

When employees are engaged in hooking, unhooking, or guiding the load, or in the initial connection of a load to a component or structure and are within the fall zone, all of the following criteria must be met:

The materials being hoisted must be rigged to prevent unintentional displacement. Only approved lifting accessories should be used.

Hooks with self-closing latches or their equivalent must be used. Exception: "J" hooks are permitted to be used for setting wooden trusses.

The materials must be rigged by a qualified rigger.

Specifications

GTH-844		
Height, stowed	7 ft 10 in	2.39 m
Length, stowed, without forks	20 ft 3 in	6.17 m
Width, standard tires	97.5 in	2.48 m
Wheelbase	11 ft 4 in	3.45 m
Ground clearance, center	1 ft 3 in	38 cm
Ground clearance, axle	1 ft 5 in	43 cm
Weight	22,600 lbs	10251 kg
Working fork height, maximum	43 ft 10 in	13.36 m
Horizontal reach, maximum	28 ft 2 in	8.59 m
Reach at maximum height	2 ft 1 in	64 cm
Lift capacity, maximum height with 24 in / 61 cm load center	6000 lbs	2722 kg
Lift capacity, maximum reach with 24 in / 61 cm load center	2000 lbs	907 kg
Maximum lift capacity	8000 lbs	3629 kg
Drive speed, maximum, Deutz engines		
3-speed transmission	15 mph	24.1 km/h
2-speed transmission	6 mph	9.7 km/h
Drive speed, maximum, Perkins 854 engines		
3-speed transmission	16 mph	25.7 km/h
2-speed transmission	6 mph	9.7 km/h
Drive speed, maximum, Perkins 1104 engines		
3-speed transmission	14 mph	22.5 km/h
2-speed transmission	5.5 mph	8.9 km/h

Tire size	13 x 24, 12 ply	
Turning radius (outside), 2 wheel steer	21 ft 9 in	6.63 m
Turning radius (outside), 4 wheel steer	13 ft 9 in	4.19 m
Frame leveling (each side)	10 degrees	
Fuel tank capacity	32 gal	121.1 liter
Hydraulic tank capacity	35 gal	132.5 liter
DEF tank capacity, Deutz	2.6 gal	10 liter
DEF tank capacity, Perkins	5.0 gal	19 liter
Maximum grade	50%	
Horn sound level, manufacturer's rating	113 dB	
Backup alarm sound level, manufacturer's rating	107 dB	
Rear proximity alarm sound level	80 dB	
Backup camera monitor sound level, manufacturer's rating	88 dB	
Maximum rear proximity sensor detection range	15 ft	4.6 m
Maximum rear proximity alarm driving speed, in reverse	3 ft/sec	0.9 m/sec
Minimum rear proximity sensor detection height, at a distance of 3 ft / 0.9 m	2 ft	0.6 m
Floor loading information		
Tire load maximum	15,100 lbs	6849 kg
Occupied floor pressure	184 psf	8.8 kPa

Specifications

Rear Proximity Sensor Range

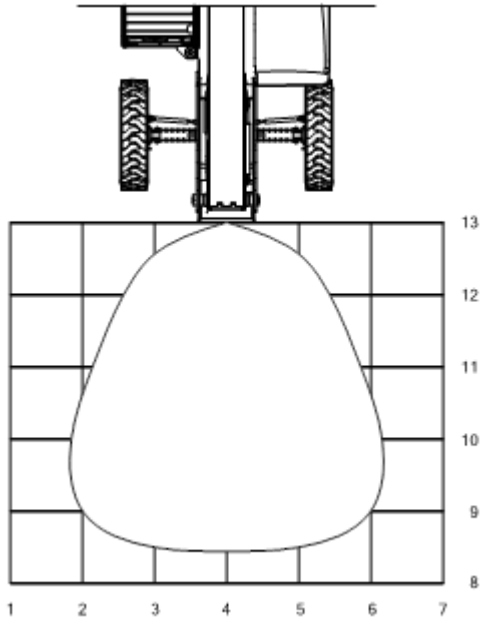

Horizontal Values		Vertical Values	
1	9.75 ft 3 m	8	16.25 ft 5 m
2	6.5 ft 2 m	9	13 ft 4 m
3	3.25 ft 1 m	10	9.75 ft 3 m
4	0 ft 0 m	11	6.25 ft 2 m
5	3.25 ft 1 m	12	3.25 ft 1 m
6	6.5 ft 2 m	13	0 ft 0 m
7	9.75 ft 3 m		

Approximate detection range. Minimum rear proximity sensor detection height is 2 ft/0.6 m.

Load Charts

Load Capacity Field Calculations

Always center the load on the forks. Position the load so that it is completely against the back of the fork frame. Fork length should always be at least 2/3 the load length.

All Genie telehandler fork carriage load charts are based on a horizontal load center that is 24 in/61 cm from the front vertical surface of the fork arm. For loads with a load center exceeding this value, refer to the table and instructions below to determine the reduced load capacity for a specific load zone. Note that this does not account for a load center that is not centered between the forks or a vertical load center exceeding 24 in/61 cm from the top face of the fork tine. Keep the load centered on the fork carriage.

To calculate the new reduced load capacity at a load center greater than the standard 24 in/61 cm load center, multiply the zone capacity from the load chart by the appropriate reduction factor listed in the table below. Refer to the example.

New Horizontal Load Center, measured from front vertical surface of fork arm

	24 in/ 61 cm or less	28 in/ 71 cm or less	32 in/ 81 cm or less	36 in/ 91 cm or less	40 in/ 102 cm or less	44 in/ 112 cm or less	48 in/ 122 cm or less	54 in/ 137 cm or less
Capacity Reduction Factor	1.00	0.86	0.75	0.67	0.60	0.55	0.50	0.44

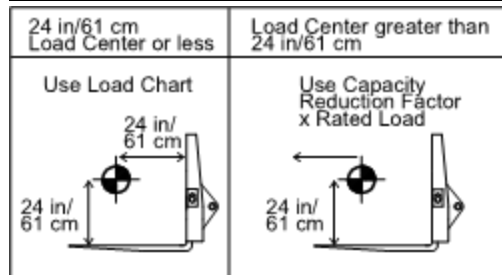

EXAMPLE

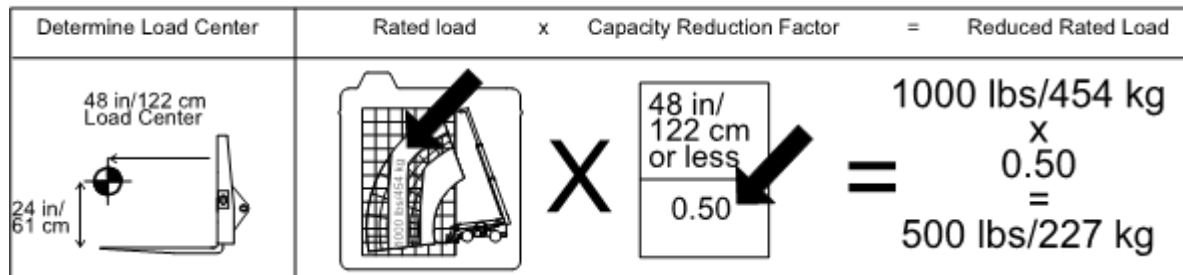

Load Charts

GTH-844 - Load Chart, STD Carriage, Fork Positioner, Side Shift

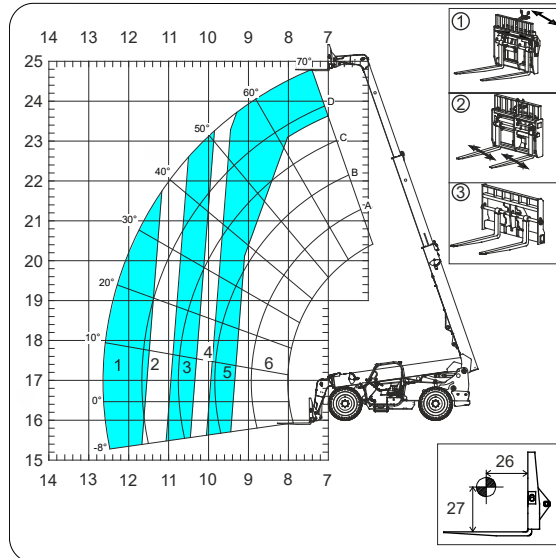

Maximum Load Capacity

1	2000 lbs	907 kg	2	3000 lbs	1360 kg
3	4000 lbs	1815 kg	4	5000 lbs	2268 kg
5	6000 lbs	2721 kg	6	8000 lbs	3628 kg

Horizontal Values

7	0 ft	0 m
8	5 ft	1.52 m
9	10 ft	3.04 m
10	15 ft	4.57 m
11	20 ft	6.10 m
12	25 ft	7.62 m
13	30 ft	9.14 m
14	35 ft	10.67 m

Vertical Values

15	-5 ft	-1.52 m
16	0 ft	0 m
17	5 ft	1.52 m
18	10 ft	3.04 m
19	15 ft	4.57 m
20	20 ft	6.10 m
21	25 ft	7.62 m
22	30 ft	9.14 m
23	35 ft	10.67 m
24	40 ft	12.20 m
25	45 ft	13.71 m
26	24 in	61 cm
27	24 in	61 cm

Load Charts

GTH-844 - Load Chart, Adjustable Truss Boom

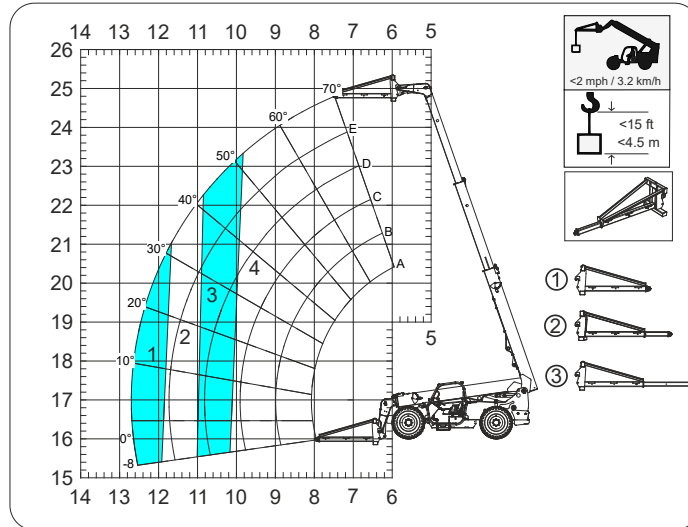

Maximum Load Capacity

	Position 1		Position 2		Position 3	
1	1500 lbs	680 kg	1500 lbs	680 kg	1500 lbs	680 kg
2	2000 lbs	907 kg	2000 lbs	907 kg	2000 lbs	907 kg
3	3000 lbs	1360 kg	3000 lbs	1360 kg	2000 lbs	907 kg
4	4000 lbs	1814 kg	3000 lbs	1360 kg	2000 lbs	907 kg

Horizontal Values

5	-5 ft	-1.52 m
6	0 ft	0 m
7	5 ft	1.52 m
8	10 ft	3.04 m
9	15 ft	4.57 m
10	20 ft	6.10 m
11	25 ft	7.62 m
12	30 ft	9.14 m
13	35 ft	10.67 m
14	40 ft	12.20 m

Vertical Values

15	-5 ft	-1.52 m
16	0 ft	0 m
17	5 ft	1.52 m
18	10 ft	3.04 m
19	15 ft	4.57 m
20	20 ft	6.10 m
21	25 ft	7.62 m
22	30 ft	9.14 m
23	35 ft	10.67 m
24	40 ft	12.20 m
25	45 ft	13.71 m
26	50 ft	15.24 m

Load Charts

GTH-844 - Load Chart, Bucket

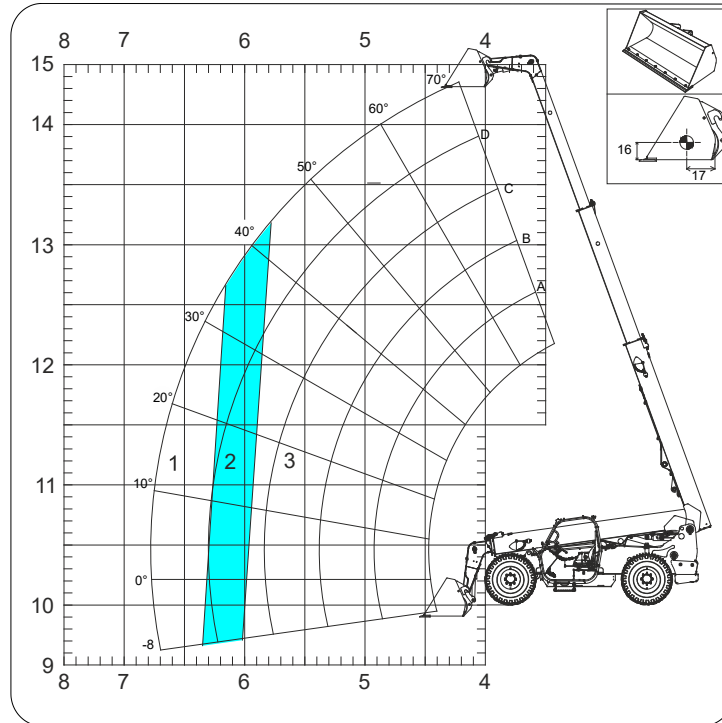

Maximum Load Capacity

1	1600 lbs	727 kg		2	3000 lbs	1360 kg
3	4000 lbs	1814 kg		4		

Horizontal Values

4	0 ft	0 m
5	10 ft	3.0 m
6	20 ft	6.10 m
7	30 ft	9.14 m
8	35 ft	10.67 m

Vertical Values

9	-5 ft	-1.5 m
10	0 ft	0 m
11	10 ft	3.0 m
12	20 ft	6.10 m
13	30 ft	9.14 m
14	40 ft	12.20 m
15	45 ft	13.71 m
16	24 in	60 cm
17	24 in	60 cm

Load Charts

GTH-844 Rotate Carriage

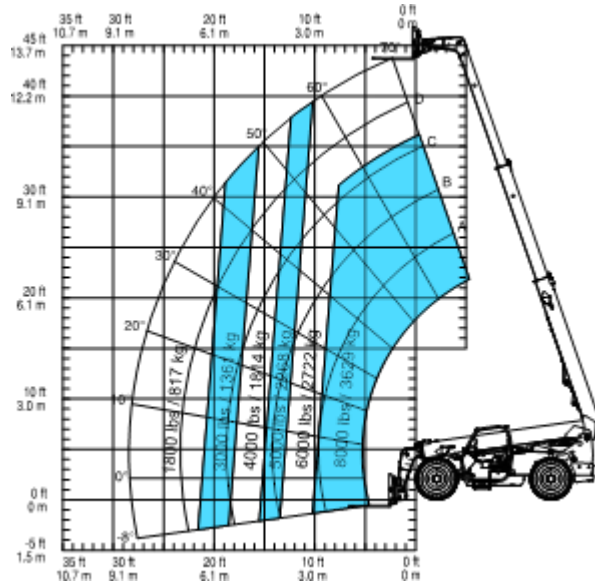

GTH-844 Quick Attach Lifting Point

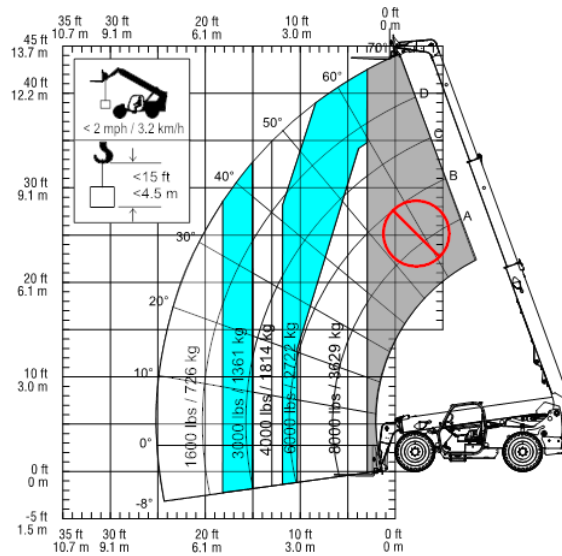

Load Charts

GTH-844 Swing Carriage

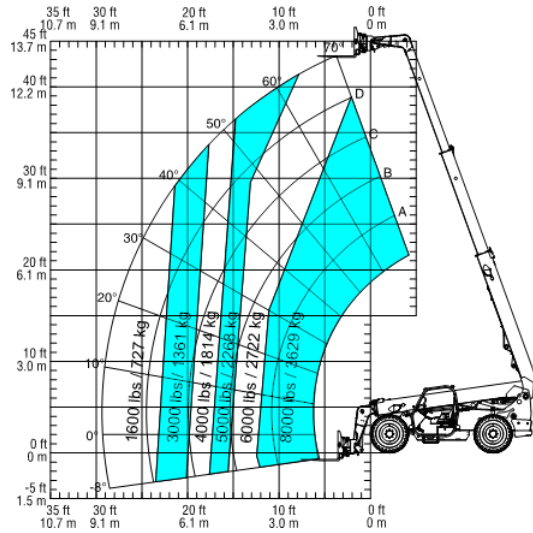

California Proposition 65



Operating, servicing and maintaining this equipment can expose you to chemicals including engine exhaust, carbon monoxide, phthalates, and lead, which are known to the State of California to cause cancer and birth defects or other reproductive harm. These chemicals can be emitted from or contained in other various parts and systems, fluids and some component wear by-products. To minimize exposure, avoid breathing exhaust, do not idle the engine except as necessary, service your equipment and vehicle in a well-ventilated area and wear gloves or wash your hands frequently when servicing your equipment or vehicle and after operation. For more information go to www.P65Warnings.ca.gov/passenger-vehicle.

Breathing diesel engine exhaust exposes you to chemicals known to the State of California to cause cancer and birth defects or other reproductive harm.

- Always start and operate the engine in a well-ventilated area.
- If in an enclosed area, vent the exhaust to the outside.
- Do not modify or tamper with the exhaust system.
- Do not idle the engine except as necessary.

For more information go to www.P65warnings.ca.gov/diesel.