



# ***Operator's Manual***

Serial number range

***GTH-5519***

From GTH55M-7009  
to GTH55M-11699

**Tier 4 Interim**  
**Tier 4 Final**

**Original Instructions**  
**Fourth Edition**  
**Fourth Printing**  
**September 2019**  
**Part No. 57.0009.0619GT**

---

## Contents

Introduction.....	1
Symbol and Hazard Pictorials Definitions.....	5
General Safety.....	6
Work Area Safety .....	10
Legend.....	17
Controls .....	18
Inspections .....	23
Operating Instructions .....	34
Transport and Lifting Instructions .....	44
Maintenance .....	47
Attachments.....	51
Specifications .....	57
Load Charts.....	59

---

Copyright © 2019 by Terex Corporation

Fourth Edition: Fourth Printing, September 2019

Genie is a registered trademark of Terex South Dakota, Inc. in the U.S.A. and many other countries. "GTH" is a trademark of Terex SouthDakota, Inc.

# Introduction

## About This Manual

Genie appreciates your choice of our machine for your application. Our number one priority is user safety, which is best achieved by our joint efforts. This book is an operation and daily maintenance manual for the user or operator of a Genie machine.

This manual, along with the AEM Rough Terrain Forklift Safety Manual, should be considered a permanent part of your machine and should remain with the machine at all times. If you have any questions, contact Genie.

## Product Identification

The machine serial number is located on the serial label.

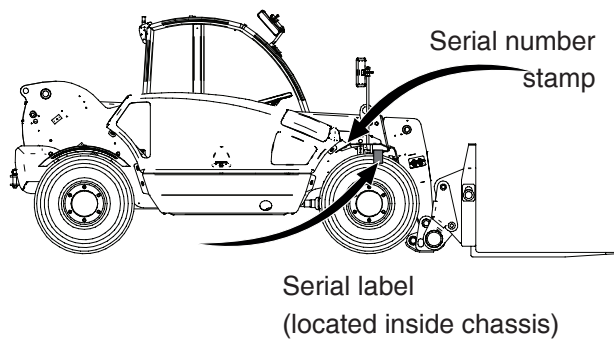

## Intended Use

A variable reach rough terrain forklift truck is defined as a wheeled type truck with a pivoting boom, which may be equipped with various attachments for picking, transporting and placing loads with the established load range charts.

Use of this product in any other way is prohibited and contrary to its intended use.

## Bulletin Distribution and Compliance

Safety of product users is of paramount importance to Genie. Various bulletins are used by Genie to communicate important safety and product information to dealers and machine owners.

The information contained in the bulletins is tied to specific machines using the machine model and serial number.

Distribution of bulletins is based on the most current owner on record along with their associated dealer, so it is important to register your machine and keep your contact information up to date.

To ensure safety of personnel and the reliable continued operation of your machine, be sure to comply with the action indicated in a respective bulletin.

## Introduction

### Contacting the Manufacturer

At times it may be necessary to contact Genie.

When you do, be ready to supply the model number and serial number of your machine, along with your name and contact information.

At minimum, Genie should be contacted for:

- Accident reporting
- Questions regarding product applications and safety
- Standards and regulatory compliance information
- Questions regarding Product Modifications
- Current owner updates, such as changes in machine ownership or changes in your contact information. See Transfer of Ownership, below.

### Transfer of Machine Ownership

Taking a few minutes to update owner information will ensure that you receive important safety, maintenance and operating information that applies to your machine.

Please register your machine by visiting us on the web at [www.genielift.com](http://www.genielift.com) or by calling us toll free at 1-800-536-1800.

## Introduction



---

### Danger

Failure to obey the instructions and safety rules in this manual will result in death or serious injury.

---

### Do Not Operate Unless:

- You learn and practice the principles of safe machine operation contained in this operator's manual.
  - 1. Avoid hazardous situations.**
  - Know and understand the safety rules before going on to the next section.**
  - 2. Always perform a pre-operation inspection.
  - 3. Always perform function tests prior to use.
  - 4. Inspect the workplace.
  - 5. Only use the machine as it was intended.
- You read, understand and obey the manufacturer's instructions and the safety rules, the safety and operator's manuals, and the decals applied on the machine.
- You read, understand and obey the employer's safety rules and worksite regulations.
- You read, understand and obey all applicable governmental regulations.
- You are properly trained to safely operate the machine.

# Introduction

## Hazard Classification



Safety alert symbol - used to alert you to potential personal injury hazards. Obey all safety messages that follow this symbol to avoid possible injury or death

**▲ DANGER** Indicates a hazardous situation which, if not avoided, will result in death or serious injury.

**▲ WARNING** Indicates a hazardous situation which, if not avoided, could result in death or serious injury.

**▲ CAUTION** Indicates a hazardous situation which, if not avoided, could result in minor or moderate injury.

**NOTICE** Indicates a property damage message.

## Standards

Many aspects of rough terrain forklift operation and testing are discussed in standards published by the American National Standards Institute and the Industrial Truck Standards Development Foundation. These standards are updated on a regular basis with addenda. It is recommended that you purchase and refer to the following standards.

ANSI/ITSDF B56.6 - Rough Terrain Forklift Trucks

The ANSI standard can be downloaded from [www.ITSDF.org](http://www.ITSDF.org)

CSA B335 - Safety Standard for Lift Trucks

The CSA standard can be downloaded from [www.csa.ca](http://www.csa.ca)

## Safety Sign Maintenance

Safety signs are designed and fitted to the machine to warn of possible hazards. They must be replaced immediately if they become unreadable or lost. If the machine is repaired and parts have been replaced on which safety signs were attached, be sure new safety signs are installed before the machine is put into service. Use mild soap and water to clean safety signs. Do not use solvent based cleaners, which may damage the safety sign material.

## Symbol and Hazard Pictorials Definitions

					
Electrocution hazard	Maintain required clearance.	Crush hazard.	No people under load	Read the operator's manual.	Injection hazard
					
Use a piece of cardboard or paper to search for leaks	Maintain required clearance.	Crush hazard.	Always wear seat belt.	Tip-over hazard	Tip-over hazard
					
Crush hazard.	Keep away from moving parts.	Crush Hazard	Keep clear of moving parts.	Burn hazard.	Do not loosen cap until cool.
					
Explosion/burn hazard	No smoking. No open flame.	Burn Hazard	Allow surfaces to cool.	Do not use starting aids	Explosion hazard
					
Access by trained and authorized personnel only	Explosion/burn hazard	No smoking. No open flame.	Fall hazard	Work platform use	Refer to load charts and manual
					
Sway operation	Keep load low	Apply maintenance collar			

# General Safety for Tier 4 Interim

**237598**  
**WARNING**  
 Crush Hazard  
 Contact between wheel and chassis can result in death or serious injury.

**237601**  
**DANGER**  
 Explosions / Burn Hazard  
 Battery explosion and/or contact with corrosive acid will result in death or serious injury.

**237601**  
 Keep all open flames and sparks away.

**237601**  
 Wear safety protective equipment, including face shield, gloves and long sleeve shirt. Read manuals. If you do not understand the information in the manuals, consult your supervisor, the owner or the manufacturer.

**215268**  
**WARNING**  
 Fall Hazard  
 Falling can result in death or serious injury.

**215268**  
 When filling personnel, only use a work platform that meets level requirements, along with associated machine load charts.

**214418**  
 Do not use other high energy starting aids on machines equipped with glow plugs or grid heater.

**214418**  
 Do not touch. Allow surfaces to cool before servicing.

**237605**  
**WARNING**  
 Explosion Hazard  
 Death or serious injury can result from the use of other or other high energy starting aids.

**237605**  
 Do not use either or other high energy starting aids on machines equipped with glow plugs or grid heater.

**237598**  
 Stay clear of machine during operation.

**237598**  
**WARNING**  
 Burn Hazard  
 Contact with hot surfaces can cause burns.

**237598**  
 Do not touch. Allow surfaces to cool before servicing.

**237602**  
**WARNING**  
 Burn Hazard  
 Contact with hot surfaces can cause burns.

**237602**  
 Do not touch. Allow surfaces to cool before servicing.

**237602**  
 Improper operation or maintenance of this equipment can result in death or serious injury.

**237602**  
 Access by trained and authorized personnel only.

**237602**  
**WARNING**  
 Crush Hazard  
 Contact with moving attachments or boom can result in death or serious injury.

**237602**  
 Securely attach the safety collar to the lifting cylinder rod before servicing.

**97667**  
**WARNING**  
 Burn Hazard  
 Contact with hot surfaces can cause burns.

**97667**  
 Do not touch. Allow surfaces to cool before servicing.

**97667**  
 Improper operation or maintenance of this equipment can result in death or serious injury.

**97667**  
 Access by trained and authorized personnel only.

**97667**  
**WARNING**  
 Crush Hazard  
 Contact with moving attachments or boom can result in death or serious injury.

**97667**  
 Securely attach the safety collar to the lifting cylinder rod before servicing.



# General Safety for Tier 4 Interim

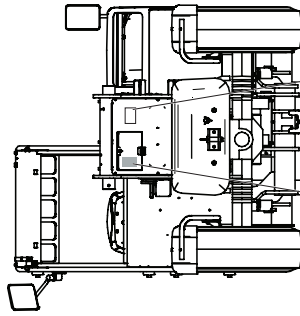

237598

**▲ WARNING**

**Crush Hazard**  
Contact between wheel and chassis can result in death or serious injury.

Stay clear of machine during operation.

**▲ DANGER**

**Crush Hazard**  
Contact with falling load can result in death or serious injury.

Stay clear of raised boom or load.

214418

**▲ DANGER**

**Electrocution Hazard**  
Contact with electric power lines will result in death or serious injury.

Stay clear of machine.

237971

**▲ DANGER**

**Explosion/Burn Hazard**  
Fuel and fumes can explode and burn, resulting in death or serious injury.

No smoking.  
Keep all open flames and sparks away.  
Stop engine before adding fuel.

237971 237598

82558 237598 214418

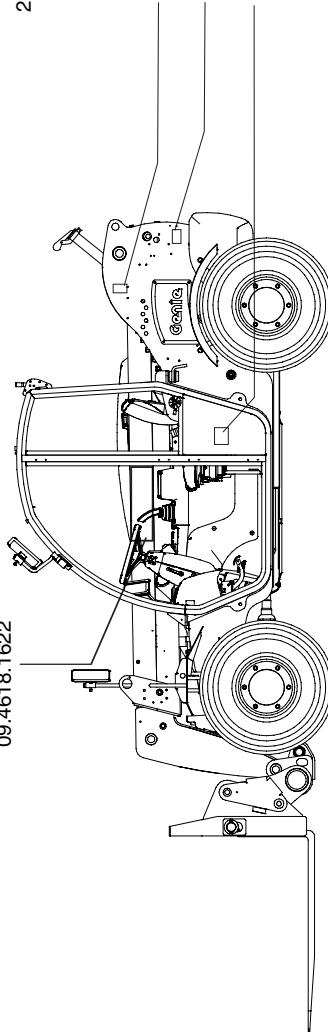

09.4618.1622

82558

**▲ WARNING**

**Injection Hazard**  
Escaping fluid under pressure can penetrate skin, causing serious injury.

Relieve pressure before disconnecting hydraulic lines. Keep away from leaks and hoses. Do not touch any hose or panel to search for leaks. Do not use hand.

Fluid injected into skin must be treated immediately. Seek medical attention by a doctor familiar with this type of injury or gangrene will result.

09.4618.1622

<p><b>▲ DANGER</b></p> <p><b>Electrocution Hazard</b> Contact with electric power lines will result in death or serious injury.</p> <p>Electric Power Line Clearance                  10 ft / 3.03 m                  15 ft / 4.57 m                  20 ft / 6.10 m                  25 ft / 7.62 m                  30 ft / 9.14 m                  35 ft / 10.67 m                  40 ft / 12.20 m                  45 ft / 13.72 m                  50 ft / 15.24 m                  55 ft / 16.77 m                  60 ft / 18.30 m                  65 ft / 19.81 m                  70 ft / 21.34 m                  75 ft / 22.86 m                  80 ft / 24.38 m                  85 ft / 25.91 m                  90 ft / 27.43 m                  95 ft / 28.96 m                  100 ft / 30.48 m</p>	<p><b>▲ WARNING</b></p> <p><b>Crush Hazard</b> Contact with boom or falling load can result in death or serious injury.</p> <p>Do not operate machine unless area is clear of people and obstructions.</p>	<p><b>▲ WARNING</b></p> <p><b>Tip-over Hazard</b> Traveling with an elevated load can result in death or serious injury.</p> <p>Always travel with the boom at or below horizontal.</p>	<p><b>▲ WARNING</b></p> <p><b>Tip-over Hazard</b> Tip-over hazard. Heavy control can result in death or serious injury.</p> <p>Do not use sway control when boom is extended. Read and understand operator's manual.</p>	<p><b>▲ WARNING</b></p> <p><b>Tip-over Hazard</b> Overturning this machine can result in death or serious injury.</p> <p>Never exceed rated lift capacity. Follow the instructions in the manual for safe operation. Do not operate this machine if the load capacity is exceeded. Limit travel speed according to the ground conditions. Do not operate on any surface which may cause machine to be unstable. Read and understand operator's manual.</p>	<p><b>▲ WARNING</b></p> <p><b>Increased load capacity or resistance can result in serious injury or death.</b></p> <p>Read and understand instructions in manual and all safety signs before using or maintaining machine. If you do not understand the information provided, contact your distributor, dealer, the owner or the manufacturer.</p>	<p><b>▲ WARNING</b></p> <p><b>Crush Hazard</b> Machine rollover can result in death or serious injury.</p> <p>Always fasten seat belt. Keep all body parts inside operator's cab at all times.</p>
---	--	---	--	--	--	--

# General Safety for Tier 4 Final

**237598**  
**▲ WARNING**  
23758 A  
**Crush Hazard**  
Contact between wheel and chassis can result in death or serious injury.

**237601**  
**▲ DANGER**  
Explosion / Burn Hazard  
Explosion or contact with corrosive acid will result in death or serious injury.

**237601**  
Keep all open flames and sparks away.

**237601**  
Wear personal protective equipment including eye protection, long sleeve shirt. Read manuals. If you do not understand the information in the manuals, consult your supervisor, the owner or the manufacturer.

**215268**  
97667

**214418**  
09.4618.2048

**237598**  
237605

**237605**  
1263543

**214418**  
97667

**▲ WARNING**  
215268  
THIR A  
**Fall Hazard**  
Falling can result in death or serious injury.

When lifting, operators must wear work platform that meets safety requirements, along with associated machine load charts. Be sure to properly secure platform to lift/handler. Read and understand operator's manual. Wear approved personal fall protection equipment and attach lanyard to anchor provided.

**▲ WARNING**  
97667  
1263543  
**▲ WARNING**  
Improper operation or maintenance of this equipment can result in death or serious injury.

**▲ WARNING**  
1263543  
Access by trained and authorized personnel only.  
1263543 A

**▲ WARNING**  
09.4618.2048  
**▲ WARNING**  
Crush Hazard  
Contact with moving attachments or boom can result in death or serious injury.

Securely install the safety collar to the lifting cylinder rod before servicing.  
09.4618.2048 A

**▲ WARNING**  
97667  
Burn Hazard  
Contact with hot surfaces can cause burns.

Do not touch. Allow surfaces to cool before servicing.  
97667 B

**▲ WARNING**  
97602  
Do not use ether or other high energy starting aids on machines equipped with glow plugs or grid heater.  
97602 C

**▲ WARNING**  
97602  
Explosion Hazard  
Death or serious injury can result from the use of ether or other high energy starting aids.

**▲ WARNING**  
237605  
Burn Hazard  
Release of hot fluid under pressure can result in death or serious injury.

Do not loosen cap until cool.  
237605 A

# General Safety for Tier 4 Final

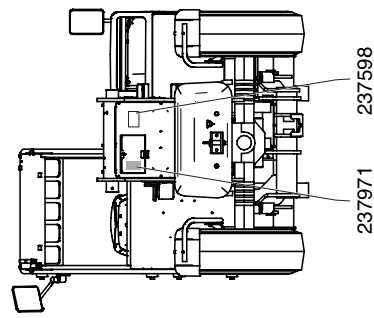

**237598**

**▲ WARNING**

**Crush Hazard**  
Contact between wheel and chassis can result in death or serious injury.

Stay clear of machine during operation.

**214418**

**▲ WARNING**

**Crush Hazard**  
Contact with falling load can result in death or serious injury.

Stay clear of raised boom or load.

**237971**

**▲ DANGER**

**Explosion/Burn Hazard**  
Fuel and fumes can explode and burn, resulting in death or serious injury.

No smoking.  
Keep all open flames and sparks away.  
Stop engine before adding fuel.

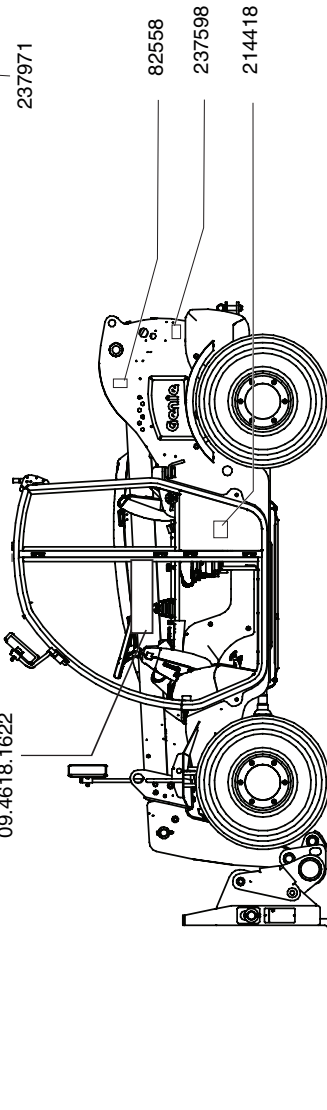

**82558**

**▲ WARNING**

**Injection Hazard**  
High pressure can penetrate skin, causing serious injury.

Relieve pressure before disconnecting hoses. Do not use compressed air to clean face, hands, or clothes. Use a piece of cardboard or paper to search for leaks. Do not use compressed air to clean clothes.  
Flats ejected into skin must be surgically removed within a few hours by a doctor familiar with the type of injury or amputation involved.

**09.4618.1622**

**▲ DANGER**

**Electrocution Hazard**  
Contact with electric power lines will result in death or serious injury.

**Crush Hazard**  
Contact with boom or falling load can result in death or serious injury.

**Tip-over Hazard**  
Overturning this machine can result in death or serious injury.

**Tip-over Hazard**  
Overturning this machine can result in death or serious injury.

**Tip-over Hazard**  
Overturning this machine can result in death or serious injury.

**Tip-over Hazard**  
Overturning this machine can result in death or serious injury.

**▲ WARNING**

**Crush Hazard**  
Machine rollover can result in death or serious injury.

Always fasten seat belt.  
Keep all body parts inside operator's cab at all times.

**▲ WARNING**

**Improper operation or maintenance can result in serious injury or death.**

Read and understand operator's manual before using or maintaining machine.  
If you do not understand the information in the manual, consult your supervisor, the owner, or the manufacturer.

**▲ WARNING**

**Tip-over Hazard**  
Overturning this machine can result in death or serious injury.

Never exceed rated lift capacity. Follow the machine load chart. Do not operate this machine on uneven ground.  
Limit travel speed according to the ground surface conditions, slopes and any other factors.  
Read and understand operator's manual.

**▲ WARNING**

**Tip-over Hazard**  
Overturning this machine can result in death or serious injury.

Do not use away control when boom is above horizontal (0°) position. Read and understand operator's manual.

**▲ WARNING**

**Tip-over Hazard**  
Overturning this machine can result in death or serious injury.

Always keep both the boom at or below horizontal.

**▲ WARNING**

**Crush Hazard**  
Contact with boom or falling load can result in death or serious injury.

Do not operate machine when people are under or near elevated boom.

**▲ DANGER**

**Electrocution Hazard**  
Contact with electric power lines will result in death or serious injury.

**Maneuver/Emergency**

0 ft 0 in	Required	10 ft 3.33 m
0 to 50 ft	Required	15 ft 4.57 m
50 to 200 ft	Required	20 ft 6.10 m
200 to 500 ft	Required	25 ft 7.62 m
500 to 750 ft	Required	30 ft 9.14 m
750 to 1000 ft	Required	35 ft 10.67 m
1000 to 1250 ft	Required	40 ft 12.20 m
1250 to 1500 ft	Required	45 ft 13.72 m

**▲ WARNING**

Do not operate machine when people are under or near elevated boom.

## Work Area Safety

### ⚠ Overturning Hazards



Using the load chart, confirm that the load is within the rated capacity of the machine. Do not exceed the rated load.

The load center of the fork (if equipped) must be equal to or less than the load center indicated on the load chart.

All loads shown on the load chart are based on the machine being on firm ground, the frame being level, the forks being positioned evenly on the carriage, the load being centered on the forks, the tires being properly sized and properly inflated, and the telehandler being in good operating condition.

If using accessories, read, understand and obey the decals, instructions and manuals with the accessory.

Do not raise the load unless the ground can support all forces imposed by the machine.

Do not lower a load without retracting the boom first.

Do not operate the machine if the load chart is missing.

Do not exceed the rated capacity for each configuration.



Do not raise the boom unless the machine is level. The machine level indicator should be at zero degrees.

Do not raise a load and then drive to position it.

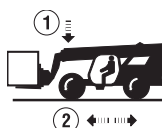

When driving, keep the boom at or below horizontal and keep the load close to the ground.

Operate the machine at speeds that will keep the load under control. Start and stop movements smoothly.



Do not raise a load unless the load is properly positioned or secured on the forks or approved attachment.

Do not operate the machine in strong or gusty winds. Do not increase the surface area of the carriage or load. Increasing the area exposed to the wind will decrease machine stability.

Use extreme care and slow speeds while driving the machine in the travel position across uneven terrain, debris, unstable or slippery surfaces and near holes and drop-offs.

Do not alter or disable machine components that in any way affect safety and stability.

Do not replace items critical to machine stability with items of different weight or specification.

Do not replace factory-installed tires with tires of different specification or ply rating.

## Work Area Safety

### ⚠ Traveling on Slopes Hazards

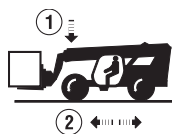

When driving, keep the boom at or below horizontal and keep the load close to the ground.

When the machine is loaded, always travel with the load uphill. When the machine is unloaded, travel with the forks or attachment downhill.

On steep terrain, drive only up and down a hill, and always keep the machine in gear. Do not turn across the slope when the machine is traveling up or down a slope.

Limit travel path and speed according to the condition of the ground surface, traction, slope, location of personnel and any other factors which may create a hazard. Never drive the machine unless the mast and equipment are in their proper travel position. Whether a machine will tip over during dynamic machine operation involves many factors that need to be considered. Among these are pavement/ground conditions, stability and slope, as well as machine equipment, operator skill, load position, tire inflation, machine speed, etc.

Additionally, tip-over of a machine is dependent in large part upon operator inputs such as the speed and smoothness of the operation, as well as the position of the attachment and its load.

Construction sites and roads will frequently change slope from place to place, can be hard and soft, and change due to construction activities and weather.

Operators should be properly trained and use their best judgment and experience to take the necessary precautions to prevent a tip-over.

Operators must assess the job site variables and avoid exceeding the machine's (or operator's) capabilities for terrain and conditions.

### ⚠ Fall Hazards



Always wear a seat belt when operating the machine.

Always remain completely inside the cab when operating the machine.

When getting in and out of the cab, face the machine, use the steps and handrails provided and always maintain three-point contact.

Do not use the steering wheel or any other controls as handrails.



Do not allow riders on the machine or forks.



Do not lift personnel with this machine unless it is equipped with an approved work platform.

## Work Area Safety

### ⚠ Collision Hazards

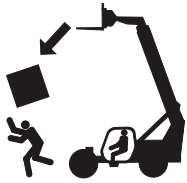

Keep people, equipment and material out of the work area. Do not operate the machine while people are under or near an elevated boom, whether it is loaded or unloaded.

Do not put the transmission into gear unless the parking brake is set.

Do not drive the machine if visibility is obstructed.

Do not raise the boom unless the parking brake is set.

Do not operate in conditions without fenders to protect debris from hitting the operator or accumulating on the cab windows.

Do not operate the machine with a faulty back-up alarm. The back-up alarm should sound when the machine is in reverse.

Do not operate the machine in low light conditions.

Operators must comply with employer, job site and governmental rules regarding use of personal protective equipment.

Do not drive the machine directly up to anyone.

Do not rely on the rear proximity alarm system to determine if personnel or objects are behind the machine. The system has limitations due to maintenance practices, the size or shape of the object, composition, environmental conditions and operating range. This system is set up for detection at a reverse speed of a maximum of 3 feet per second / 0.9 meters per second (walking pace). Refer to the detection zone chart in the back of this manual.

### ⚠ Falling Object Hazards

Operate the machine at speeds that will keep the load under control. Start and stop movements smoothly.

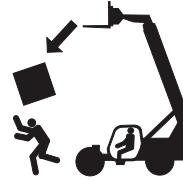

Keep people, equipment and material out of the work area. Do not operate the machine while people are under or near an elevated boom, whether it is loaded or unloaded.

Be sure the load is secure before lifting it.

## Work Area Safety

### ⚠ Bodily Injury Hazards



Always adjust the seat and fasten the seat belt before starting the engine.



Do not operate the machine with a hydraulic oil or air leak. An air leak or hydraulic leak can penetrate and/or burn skin.



Relieve pressure before disconnecting hydraulic lines. Keep away from leaks and pin holes. Use a piece of cardboard or paper to search for leaks. Do not use your hand.

Fluid injected into skin must be surgically removed within a few hours by a doctor familiar with this type of injury or gangrene will result.



Stay clear of belts and fans when the engine is running.

Always operate the machine in a well-ventilated area to avoid carbon monoxide poisoning.

Improper contact with components under any cover will cause serious injury. Only trained maintenance personnel should access compartments. Access by the operator is only advised when performing a pre-operation inspection. All compartments must remain closed and secured during operation.

### ⚠ Damaged Machine Hazards

Do not use a damaged or malfunctioning machine.

Conduct a thorough pre-operation inspection of the machine and test all functions before each work shift. Immediately tag and remove from service a damaged or malfunctioning machine.

Be sure all maintenance has been performed as specified in this manual and the appropriate Genie service manual.

Be sure all decals are in place and legible.

Be sure the operator's and safety manuals are complete, legible and in the storage container located in the cab.

Do not attempt to start the machine by towing or pushing.

Do not attempt to use the forks or attachments for prying wedged or frozen loads free.

Do not push or pull objects or loads with the forks, attachment or boom.

## Work Area Safety

### ⚠ Component Damage Hazards

Do not use any battery or charger greater than 12V to jump-start the engine.

Do not use the machine as a ground for welding.

### ⚠ Crush Hazards

Keep clear of moving parts during machine operation.

Set the parking brake, put the transmission in neutral and lower the carriage or the attachment to the ground before leaving the machine.

Keep clear of elevated components.

Support components before performing service. Keep clear of moving parts during machine operation.

### ⚠ Burn Hazards



Allow hot surfaces to cool before touching or servicing.

### ⚠ Explosion and Fire Hazards

Do not start the engine if you smell or detect liquid petroleum gas (LPG), gasoline, diesel fuel or other explosive substances.

Do not refuel the machine with the engine running.



Refuel the machine and charge the battery only in an open, well-ventilated area away from sparks, flames and lighted tobacco.

Do not operate the machine in hazardous locations or locations where potentially flammable or explosive gases or particles may be present.

Do not spray ether into engines equipped with glow plugs or air intake grid heaters.



## Work Area Safety

### ⚠ Electrocuting Hazards

This machine is not electrically insulated and will not provide protection from contact with or proximity to electrical current.



Obey all local and governmental regulations regarding required clearance from electrical power lines. At a minimum, the required clearance contained in the chart below must be followed.

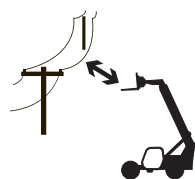

Line Voltage	Required	Clearance
0 to 50kV	10 ft	3.05 m
>50 to 200kV	15 ft	4.60 m
>200 to 350kV	20 ft	6.10 m
>350 to 500kV	25 ft	7.62 m
>500 to 750kV	35 ft	10.67 m
>750 to 1000kV	45 ft	13.72 m
over 1000kV		see below

For power lines over 1000kV, the minimum clearance distance must be established by the utility owner or operator or by a registered professional engineer who is a qualified person with respect to electrical power transmission and distribution.

Do not use the machine as a ground for welding.

Always contact the electrical power line owner. The electrical power shall be disconnected or the power lines moved or insulated before machine operations begin.

Allow for platform movement, electrical line sway or sag, and beware of strong or gusty winds.

Keep away from the machine if it contacts energized power lines. Personnel on the ground or in the platform must not touch or operate the machine until energized power lines are shut off.

Do not operate the machine during lightning or storms.

## Work Area Safety

### ⚠ Battery Safety

#### Burn Hazards



Batteries contain acid. Always wear protective clothing and eye wear when working with batteries.

Avoid spilling or contacting battery acid. Neutralize battery acid spills with baking soda and water.

#### Explosion Hazards

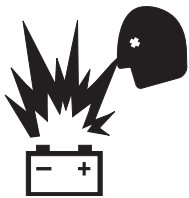

Keep sparks, flames and lighted tobacco away from batteries. Batteries emit explosive gas.



#### Electrocution Hazard

Avoid contact with electrical terminal.

### ⚠ Employer's Responsibilities

Employers are responsible for providing a safe work environment and for complying with local and national governmental regulations.

### ⚠ Personal Safety

Be sure that everyone working on or near this machine is familiar with the applicable safety precautions.

# Legend

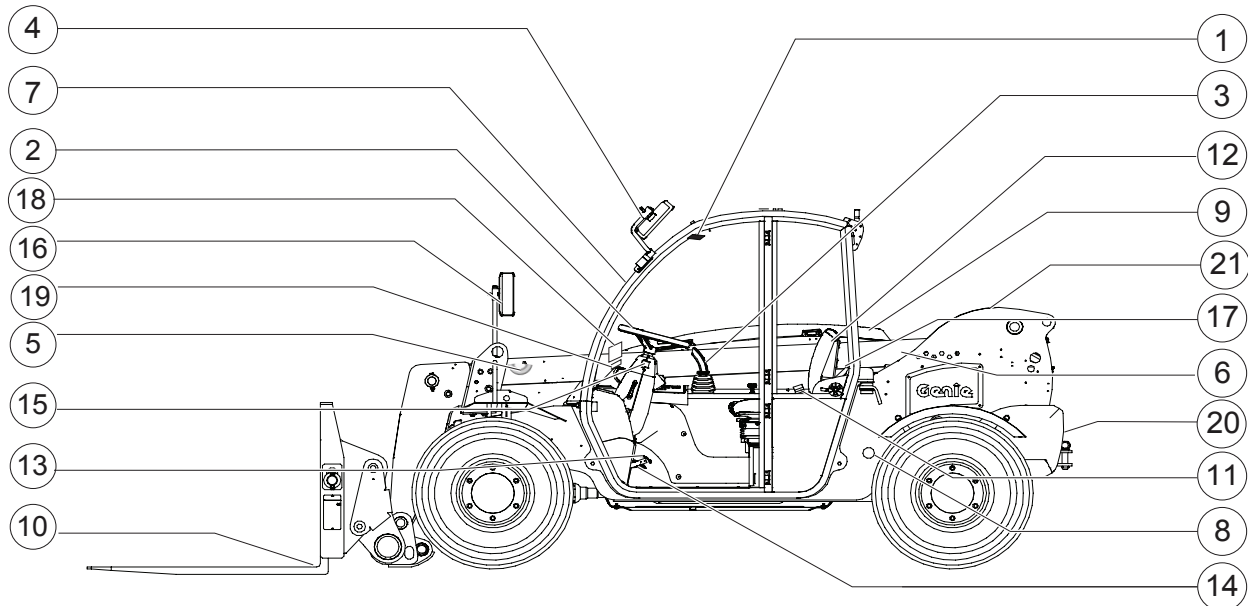

- |                               |   |
|-------------------------------|---|
| 1. Left/right level indicator | 13. Brake pedal   |
| 2. Steering wheel             | 14. Accelerator pedal                                   |
| 3. Control handle             | 15. Transmission control lever                          |
| 4. Left rear view mirror      | 16. Right rear view mirror                              |
| 5. Boom angle indicator       | 17. Operators manual storage                            |
| 6. Boom                       | 18. Load Charts   |
| 7. Cab                        | 19. Rear proximity display and alarm<br>(if equipped)   |
| 8. Hydraulic oil level gauge  | 20. Rear proximity alarm sensor<br>(if equipped)        |
| 9. Engine                     | 21. Maintenance collar (on opposite side<br>of machine) |
| 10. Forks                     |   |
| 11. Seat belt                 |   |
| 12. Seat                      |   |

# Controls

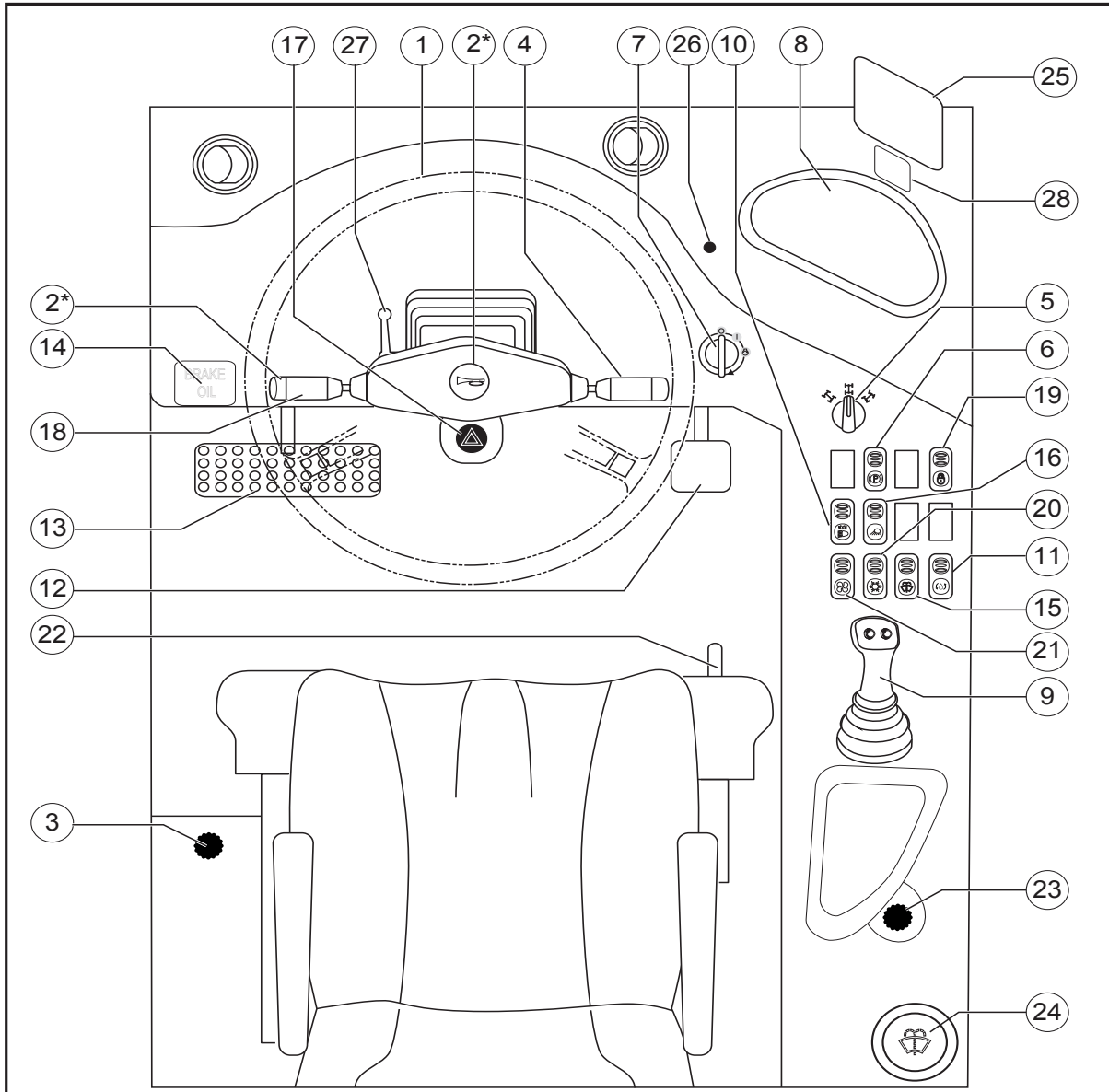

\*NOTE: The horn button 2 is positioned at the end of the transmission control lever up to machine serial number GTH55M-10886.

The horn button 2 is positioned at the centre of the steering wheel from machine serial number GTH55M-10887 and GTH55M-10851, GTH55M-10854, GTH55M-10860, GTH55M-10862, GTH55M-10863, GTH55M-10864, GTH55M-10866, GTH55M-10867, GTH55M-10869, from GTH55M-10872 to GTH55M-10882, and GTH55M-10884, GTH55M-10885.

## Controls

- 1 **Steering wheel**

Turn the steering wheel to the right to turn the front wheels to the right. Turn the steering wheel to the left to turn the front wheels to the left.
- 2 **Horn button**

Press this button and the horn will sound. Release the button and the horn will stop.
- 3 **Heater and air conditioning controls (if equipped)**
- 4 **Turn signal lever (if equipped)**

Move the lever down to activate the right turn signal. Move the lever up to activate the left turn signal.
- 5 **Steer select switch**

Rotate the steer selector to the right side to select four-wheel steer. Rotate the steer selector to the middle position to select two-wheel steer. Rotate the steer selector to the left to select crab steer.
- 6 **Parking brake switch**

Push the top of the rocker switch to turn the parking brake off. Push the bottom of the switch to turn the parking brake on.
- 7 **Ignition switch**

Turn the key to the  position and hold until the glow plugs preheating indicator light turns off; when released, key springs back to pos. I automatically.
- 8 **Instrument panel**
- 9 **Control handle**

Pull the control handle back and the boom will raise. Push the control handle forward and the boom will lower. Push the control handle to the right and the boom will extend. Pull the control handle to the left and the boom will retract. Hold down the yellow thumb switch and pull the control handle back and the forks will tilt up. Hold down the yellow thumb switch and push the control handle forward and the forks will tilt down. Hold the red thumb switch and push the control handle forward to lock the attachment. Hold the red thumb switch and push the control handle backward to unlock the attachment.
- 10 **Road lights switch (if equipped)**
- 11 **Continuous oil flow switch**

Push the switch to delivery or to return the oil flow from the used attachment.
- 12 **Accelerator pedal**
- 13 **Brake pedal**
- 14 **Service brake oil reservoir**
- 15 **Windshield washer switch (if equipped)**

Push and hold the switch to turn the washer on. Release the switch to turn the washer off.
- 16 **Work lights switch (if equipped)**

Push the center of the rocker switch to turn the cab & boom working lights on. Push the bottom of the switch to turn the cab, boom and rear working lights on. Push the top of the rocker switch to turn them off.

## Controls

- 17 Hazard warning lights switch (if equipped)  
Push the switch to turn the hazard warning lights on. Release the switch to turn the hazard warning lights off.
- 18 Transmission control lever  
Move the transmission control lever away from you for forward gear. Move the lever toward you for reverse gear. Move the lever to the center position for neutral.
- 19 Lock/unlock enabling switch (if equipped)  
Push and hold the switch to enable the coupling or the release of the attachment, managed by the control lever.
- 20 A/C switch (if equipped)  
Push the switch to turn the A/C on. Release the switch to turn the A/C off.
- 21 Cab heater fan switch (if equipped)  
Push the switch to turn the cab heater fan on: first position for low speed and second position for high speed. Release the switch to turn the cab heater fan off.
- 22 Seat adjustment
- 23 Continuous oil flow potentiometer  
Turn the potentiometer clockwise to increase the flow rate in the circuit feeding the attachments.
- 24 Windshield washer reservoir (if equipped)
- 25 Load charts holder
- 26 Diagnostic button
- 27 Steering column adjustment
28. Rear proximity display and alarm (if equipped)

# Controls

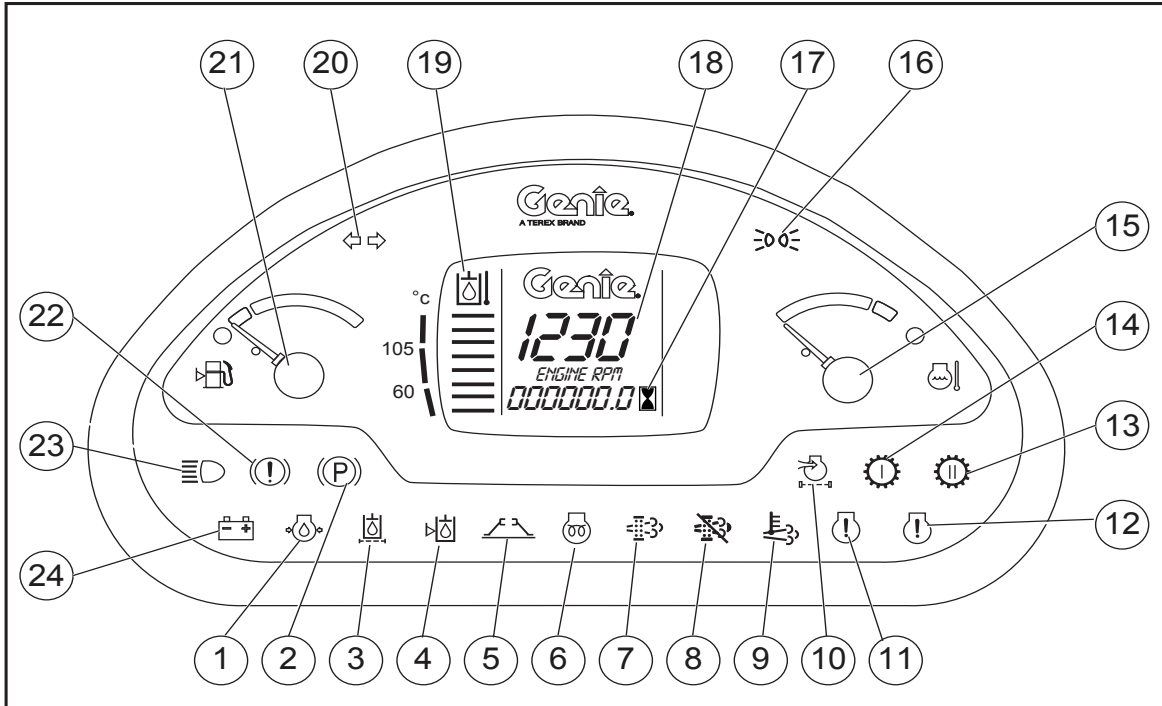

## Instrument Panel

- |  |  |
|--|--|
| 1. Low engine oil pressure indicator light       | 14. Not active   |
| 2. Parking brake engaged indicator light         | 15. Engine coolant temperature gauge with high coolant temperature indicator light |
| 3. Hydraulic oil filter clogged indicator light  | 16. Parking lights indicator light   |
| 4. Low hydraulic oil level indicator light       | 17. Hour-meter   |
| 5. Not active                                    | 18. Tachometer   |
| 6. Glow plugs preheating indicator light         | 19. High hydraulic oil temperature indicator light                                 |
| 7. Not active                                    | 20. Turn signal indicator light  |
| 8. Not active                                    | 21. Fuel level gauge with low fuel indicator light                                 |
| 9. Not active                                    | 22. Brake pressure low indicator light   |
| 10. Engine air filter restricted indicator light | 23. High beam indicator light  |
| 11. Engine Alert indicator light                 | 24. Battery voltage low indicator light  |
| 12. Engine Critical Fault indicator light        |  |
| 13. Not active                                   |  |

## Controls

### 1 Low engine oil pressure indicator light

When illuminated this light indicates that the engine oil pressure is too low which can lead to machine damage. Discontinue use of the machine and service.

### 3 Hydraulic oil filter clogged indicator light

When illuminated this light indicates that the hydraulic oil filter is clogged which can lead to machine damage. Discontinue use of the machine and service.

### 4 Low hydraulic oil level indicator light

When illuminated this light indicates that the hydraulic oil level is too low which can lead to machine damage. Replenish and eliminate any oil leaks.

### 10 Engine air filter restricted indicator light

When this lamp comes on, the engine air filter is clogged proceed with cleaning or changing the air filter cartridge.

### 11 Engine Alert indicator light

This light flashes to warn of a problem with the engine. To identify the problem, see the two sections "Engine Lamp Logic"

### 12 Engine Critical Fault indicator light

This light comes on to warn of a problem with the engine. To identify the problem, see the two sections "Engine Lamp Logic"

### 15 High engine coolant temperature gauge

When gauge reaches red, the engine coolant is too hot which can lead to engine damage. Discontinue use and service the engine

### 19 High hydraulic oil temperature indicator light

This indicates the temperature of the hydraulic oil in the tank which can lead to machine damage. Discontinue use of the machine and service.

### 22 Brake pressure low indicator light

It lights when the pressure of the braking circuit is too low for a correct functioning which can lead to machine damage. Discontinue use of the machine and service.





---

## Do Not Operate Unless:

- You learn and practice the principles of safe machine operation contained in this operator's manual.
  1. Avoid hazardous situations.
  - 2. Always perform a pre-operation inspection.**

**Know and understand the pre-operation inspection before going on to the next section.**
  3. Always perform function tests prior to use.
  4. Inspect the workplace.
  5. Only use the machine as it was intended.

# Inspections

## Pre-operation Inspection Fundamentals

It is the responsibility of the operator to perform a pre-operation inspection and routine maintenance.

The pre-operation inspection is a visual inspection performed by the operator prior to each work shift. The inspection is designed to discover if anything is apparently wrong with a machine before the operator performs the function tests.

The pre-operation inspection also serves to determine if routine maintenance procedures are required. Only routine maintenance items specified in this manual may be performed by the operator.

Refer to the list on the next page and check each of the items.

If damage or any unauthorized variation from factory delivered condition is discovered, the machine must be tagged and removed from service.

Repairs to the machine may only be made by a qualified service technician, according to the manufacturer's specifications. After repairs are completed, the operator must perform a pre-operation inspection again before going on to the function tests.

Scheduled maintenance inspections shall be performed by qualified service technicians, according to the manufacturer's specifications and the requirements listed in the responsibilities manual.

# Inspections

## Pre-operation Inspection

- Be sure that the operator's, safety and responsibilities manuals are complete, legible and in the storage container located in the cabin.
- Be sure that all decals are legible and in place. See Inspections section.
- Check for hydraulic oil leaks and proper oil level. Add oil if needed. See Maintenance section.
- Check for battery fluid leaks and proper fluid level. Add distilled water if needed. See Maintenance section.
- Check for engine oil leaks and proper oil level. Add oil if needed. See Maintenance section.
- Air-filled tires models: Check for proper tire pressure. Add air if needed. See Maintenance section.

Check the following components or areas for damage, improperly installed or missing parts and unauthorized modifications:

- Electrical components, wiring and electrical cables
- Hydraulic hoses, fittings, cylinders and manifolds
- Fuel and hydraulic tanks
- Drive motors and drive hubs
- Boom wear pads
- Tires and wheels
- Mirrors
- Engine and related components

- Limit switches
- Lights, alarms and beacons (if equipped)
- Pins, nuts, bolts and other fasteners

Check entire machine for:

- Cracks in welds or structural components
- Dents or damage to machine
- Excessive rust, corrosion or oxidation
- Be sure that all structural and other critical components are present and all associated fasteners and pins are in place and properly tightened.
- Be sure the windshield and windows (if equipped) are clean and free of obstructions that might limit visibility.
- Be sure that the rear proximity alarm, display and sensor (if equipped) are present, in place and clear of any dirt, mud, snow or debris.
- After you complete your inspection, be sure that all guards, screens and compartment covers are in place and secured.

## Inspections



---

### Do Not Operate Unless:

- You learn and practice the principles of safe machine operation contained in this operator's manual.
  1. Avoid hazardous situations.
  - 2. Always perform a pre-operation inspection.**  
**Know and understand the pre-operation inspection before going on to the next section.**
  3. Always perform function tests prior to use.
  4. Inspect the workplace.
  5. Only use the machine as it was intended.

### Function Test Fundamentals

The function tests are designed to discover any malfunctions before the machine is put into service. The operator must follow the step-by-step instructions to test all machine functions.

A malfunctioning machine must never be used. If malfunctions are discovered, the machine must be tagged and removed from service. Repairs to the machine may only be made by a qualified service technician, according to the manufacturer's specifications.

After repairs are completed, the operator must perform a pre-operation inspection and function tests again before putting the machine into service.

# Inspections

## Function Tests

- 1 Select a test area that is firm, level and free of obstruction. Be sure there is no load on the forks or attachment.
- 2 Enter the cab and sit on the seat.
- 3 Adjust the seat and steering column, if needed.
- 4 Fasten and secure the seat belt around your waist.
- 5 Adjust the cab mounted mirror and the exterior right hand mirror, if required.
- 6 Be sure the parking brake is on and the transmission control is in neutral.
- 7 Start the engine. See Starting the Engine in the Operating Instructions section.

## Test the Ignition System

- 8 Set the transmission control lever in neutral position.
- 9 Step on the brake pedal. Push the top of the parking brake switch to turn it off
- 10 Insert the key in the ignition switch.
- 11 Turn the key to start the engine.
- ⊙ Result: The engine should not start.
- 12 Set the transmission control lever in gear.
- 13 Push the bottom of the parking brake switch to turn it on.
- 14 Insert the key in the ignition switch.
- 15 Turn the key to start the engine.
- ⊙ Result: The engine should not start.

## Test the Control Handle

- 16 Start the machine with the parking brake on and the transmission control lever set to neutral position.
- 17 Using the control handle, momentarily raise the boom, extend the boom, retract the boom and lower the boom.
- ⊙ Result: All functions should operate smoothly.
- 18 Using the control handle and the yellow thumb switch, momentarily tilt the forks up and tilt the forks down.
- ⊙ Result: All functions should operate smoothly.

## Test the Lock/Unlock Function (if equipped)

- 19 Push and hold the lock/unlock enabling switch.
- 20 Using the control handle and the red finger switch, momentarily coupling or releasing the attachment.
- ⊙ Result: All functions should operate smoothly.

## Inspections

### Test the Steering

- 21 Rotate the steer selector to the right side to select four-wheel steer.
- 22 Check the steering operation by turning the steering wheel approximately  $\frac{1}{4}$  turn in each direction.
  - ⊙ Result: The front wheels should turn in the same direction as the steering wheel. The rear wheels should turn in the opposite direction.
- 23 Straighten the wheels.
- 24 Rotate the steer selector to the middle position to select two-wheel steer.
- 25 Check the steering operation by turning the steering wheel approximately  $\frac{1}{4}$  turn in each direction.
  - ⊙ Result: The front wheels should turn in the same direction as the steering wheel. The rear wheels should not turn.
- 26 Straighten the wheels.
- 27 Rotate the steer selector to the left to select crab steer.
- 28 Check the steering operation by turning the steering wheel approximately  $\frac{1}{4}$  turn in each direction.
  - ⊙ Result: The front wheels and the rear wheels should turn in the same direction as the steering wheel.

### Test the Transmission and Brakes

- 29 Be sure the boom is fully lowered and retracted.
- 30 Step on the brake pedal. Push the top of the parking brake switch to turn it off.
- 31 Move the transmission control lever to forward. Slowly let up on the brake pedal. As soon as the machine starts to move, push the brake pedal.
  - ⊙ Result: The machine should move forward, and then come to an abrupt stop.
- 32 Move the transmission control lever to reverse. Slowly let up on the brake pedal. As soon as the machine starts to move, push the brake pedal.
  - ⊙ Result: The machine should move in reverse, and then come to an abrupt stop. The back-up alarm should sound when the transmission control lever is in reverse.
- 33 Move the transmission control lever to neutral.
- 34 Push the bottom of the parking brake switch.
  - ⊙ Result: The red parking brake indicator light should come on, indicating the parking brake is on.
- 35 Move the transmission control lever forward, and then in reverse.
- 36 With the foot on the service brake, slowly release the service brake.
  - ⊙ Result: The machine should not move.

## Inspections

### Test the Drive

- 37 Step on the brake pedal.
- 38 Push the bottom of the parking brake switch. The parking brake is off when the indicator light is off.
- 39 Put the transmission control lever in forward.
- ⚠ Slowly let up on the brake pedal.
- ⦿ Result: The drive function should not operate.

### Test the Lights (if equipped)

- 40 Verify that all lights are functional.

### Test the Rear Proximity Alarm System (if equipped)

The system provides a visible and audible indication of objects behind the machine, when they are within the detection range of the sensor and while in reverse gear.

Be sure that there are no personnel and obstacles behind the machine which the sensor may detect on startup.

- 41 Locate a sizable item, like a safety cone or pallet of bricks, that the sensor will detect and position the rear of the telehandler about 15 feet / 4.5 meters in front of it. Do not perform the function test if there are people behind the machine.
- 42 Set the parking brake, place the transmission into neutral and start the engine. Press and hold the brake pedal and place the transmission in reverse.
- ⦿ Result: The green power light on the rear proximity display should be on. If the green power light is not on, the system needs to be repaired.

- 43 Release the parking brake and slowly let up on the brake pedal and slowly approach the object. Stop the machine before it reaches the object.
  - ⦿ Result: The rear proximity display should show an orange light on. The alarm should sound with increased frequency as the machine approaches the object.
- 44 Place the transmission in forward and slowly drive away from the object.
  - ⦿ The rear proximity display should show an orange light on, and the alarm should sound with decreased frequency as the machine moves away the object.
  - ⦿ As the machine moves away from the object, the display should show the green light on, and no alarm should be sounding.
- 45 Stop the machine, place the transmission in neutral and turn off the engine.



---

## Do Not Operate Unless:

- You learn and practice the principles of safe machine operation contained in this operator's manual.
  1. Avoid hazardous situations.
  - 2. Always perform a pre-operation inspection.**

**Know and understand the pre-operation inspection before going on to the next section.**
  3. Always perform function tests prior to use.
  4. Inspect the workplace.
  5. Only use the machine as it was intended.

## Workplace Inspection Fundamentals

The workplace inspection helps the operator determine if the workplace is suitable for safe machine operation. It should be performed by the operator prior to moving the machine to the workplace.

It is the operator's responsibility to read and remember the workplace hazards, then watch for and avoid them while moving, setting up and operating the machine.

# Inspections

## Workplace Inspection Checklist

Be aware of and avoid the following hazardous situations:

- drop-offs or holes
- bumps, floor obstructions or debris
- sloped surfaces
- unstable or slippery surfaces
- overhead obstructions and high voltage conductors
- hazardous locations
- inadequate surface support to withstand all load forces imposed by the machine
- wind and weather conditions
- the presence of unauthorized personnel
- other possible unsafe conditions

## Inspections

### Inspection for Decals with Words for Tier 4 Interim

Determine whether the decals on your machine have words or symbols. Use the appropriate inspection to verify that all decals are legible and in place.

Part No.	Decal Description	Qty
28159	Label – Diesel	1
1263543	Warning – Compartment Access	1
97602	Warning – Explosion Hazard	1
82366	Label – Chevron Rando HD	1
82558	Warning – Skin Injection Hazard	1
97667	Warning – Burn Hazard	3
214418	Danger/Warning – 2 Decal Combination	3
215267	Label – Product Registration	1
215268	Warning – Fall Hazard, Work Platform	1
237598	Warning – Crush Hazard, Moving Machine	3
237601	Danger – Explosion/Burn Hazard	1
237605	Warning – Burn Hazard, Hot Parts	1
237971	Danger – Explosion/Burn Hazard, Fueling	1
09.4618.0643	Cosmetic - Genie GTH-5519	2
09.4618.0644	Cosmetic - GTH-5519	2
09.4618.1622	Danger/Warning – 7 Decal Combination	1
09.4618.1634	Label - Hydraulic Flow	1
09.4618.1688	Label - Control Lever	1

Part No.	Decal Description	Qty
09.4618.1690	Label - Lifting & Anchoring	1
09.4618.1691	Label - Testing Ports	1
09.4618.0776	Label - Door internal unlock system	1
09.4618.1025	Label - Upper Door External Unlock System	1
09.4618.1742	Label - Emergency Exit Handles	1
1258639	Cosmetic - Genie Low Relief	1
09.4618.1999	Decal - Brakes Oil Pan	1
09.4618.2048	Warning - Crush Hazard, Use Safety Collar	1
1280819	Decal - Warning Cancer and Reproductive Harm, Prop 65	1
1280820	Decal - Fuel, Diesel Exhaust, Prop 65	1
09.4618.1738	Label - Load Chart, Standard Carriage	1
09.4618.0801	Label - Load Chart 60 And 66 Inch Bucket	1
09.4618.0802	Label - Load Chart Scrap Grapple Bucket	1
09.4618.0803	Label - Load Chart 60 Inch Forks - Optional 48 Inch Forks - 48 Inch Cubing Tines	1
09.4618.0804	Label - Load Chart Universal Attachment Adapter	1
09.4618.0805	Label - Load Chart Rotating Or Side Shift Fork Carriage - Standard Fork Tines	1
09.4618.0806	Label - Load Chart Truss Boom	1
09.4618.1680	Label - Load Chart Side Shift Fork Carriage - 60" Fork Tines	1
09.4618.1867	Label - Load Chart Shackle	1



# Inspections

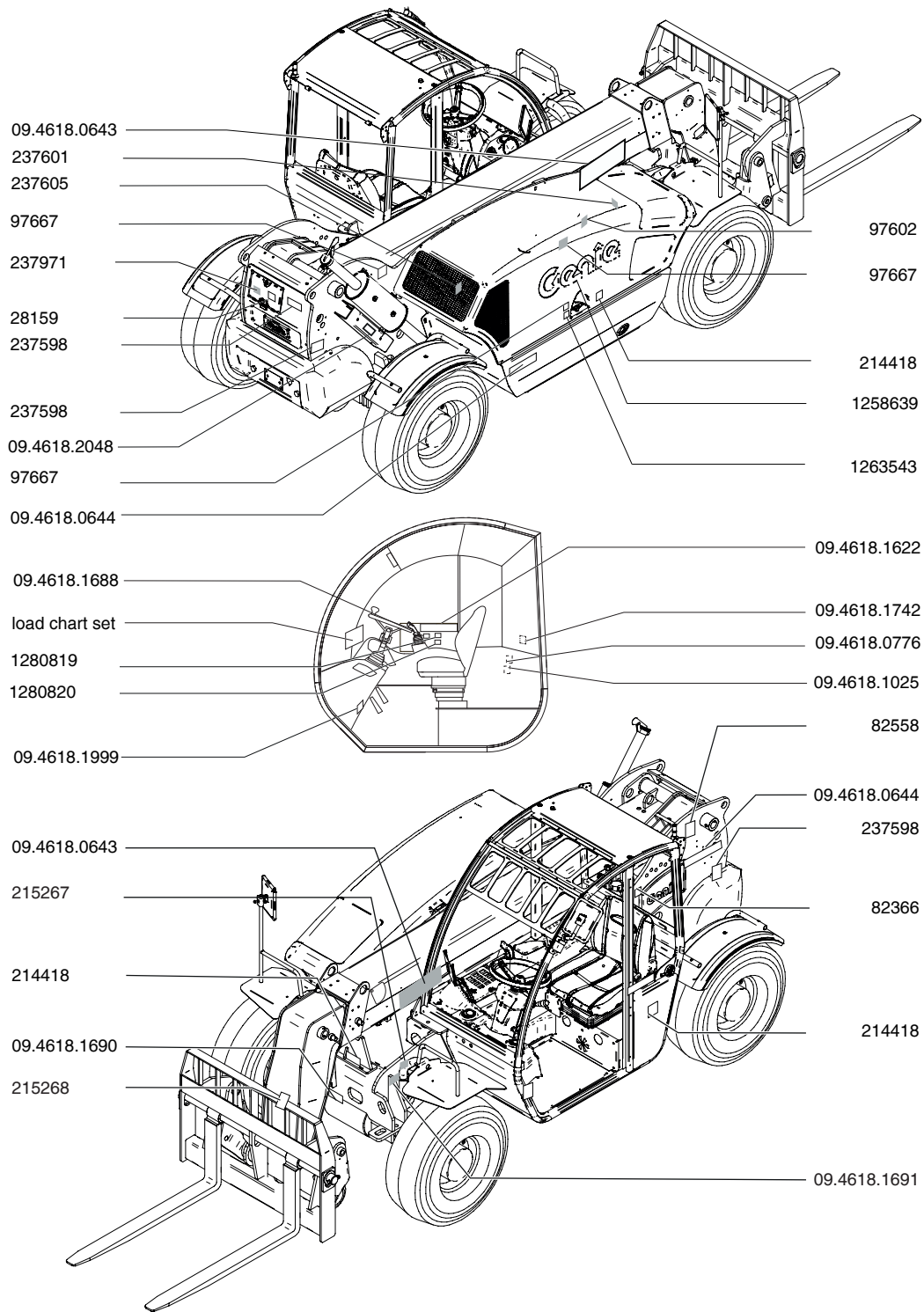

■ Shading indicates decal is hidden from view, i.e. under covers

# Inspections

## Inspection for Decals with Words for Tier 4 Final

Determine whether the decals on your machine have words or symbols. Use the appropriate inspection to verify that all decals are legible and in place.

Part No.	Decal Description	Qty	Part No.	Decal Description	Qty
28159	Label – Diesel	1	09.4618.1688	Label - Control Lever	1
1263543	Warning – Compartment Access	1	09.4618.1690	Label - Lifting & Anchoring	1
97602	Warning – Explosion Hazard	1	09.4618.1691	Label - Testing Ports	1
82366	Label – Chevron Rando HD	1	09.4618.0776	Label - Door internal unlock system	1
82558	Warning – Skin Injection Hazard	1	09.4618.1025	Label - Upper Door External Unlock System	1
97667	Warning – Burn Hazard	3	09.4618.1742	Label - Emergency Exit Handles	1
214418	Danger/Warning – 2 Decal Combination	3	1258639	Cosmetic - Genie Low Relief	1
215267	Label – Product Registration	1	09.4618.1999	Decal - Brakes Oil Pan	1
215268	Warning – Fall Hazard, Work Platform	1	09.4618.2048	Warning – Crush Hazard, Use Safety Collar	1
237598	Warning – Crush Hazard, Moving Machine	3	1280819	Decal - Warning Cancer and Reproductive Harm, Prop 65	1
237601	Danger – Explosion/Burn Hazard	1	1280820	Decal - Fuel, Diesel Exhaust, Prop 65	1
237605	Warning – Burn Hazard, Hot Parts	1	09.4618.1738	Label - Load Chart, Standard Carriage	1
237971	Danger – Explosion/Burn Hazard, Fueling	1	09.4618.0801	Label - Load Chart 60 And 66 Inch Bucket	1
826345	Label – Ultra Low Sulfur Fuel Only	1	09.4618.0802	Label - Load Chart Scrap Grapple Bucket	1
09.4618.0643	Cosmetic - Genie GTH-5519	2	09.4618.0803	Label - Load Chart 60 Inch Forks - Optional 48 Inch Forks - 48 Inch Cubing Tines	1
09.4618.0644	Cosmetic - GTH-5519	2	09.4618.0804	Label - Load Chart Universal Attachment Adapter	1
09.4618.1622	Danger/Warning – 7 Decal Combination	1	09.4618.0805	Label - Load Chart Rotating Or Side Shift Fork Carriage - Standard Fork Tines	1
09.4618.1634	Label - Hydraulic Flow	1	09.4618.0806	Label - Load Chart Truss Boom	1
			09.4618.1680	Label - Load Chart Side Shift Fork Carriage - 60" Fork Tines	1
			09.4618.1867	Label - Load Chart Shackle	1

# Inspections

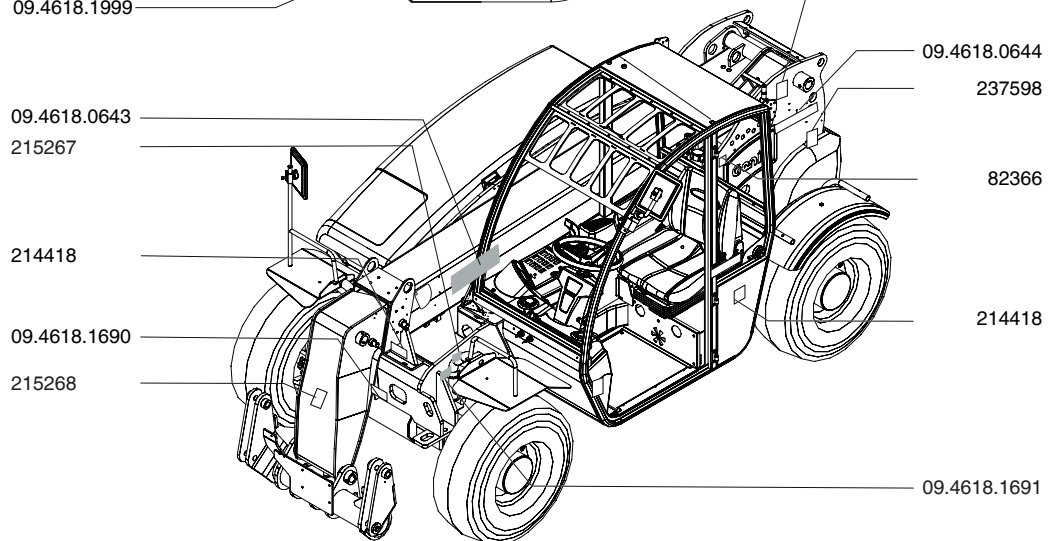
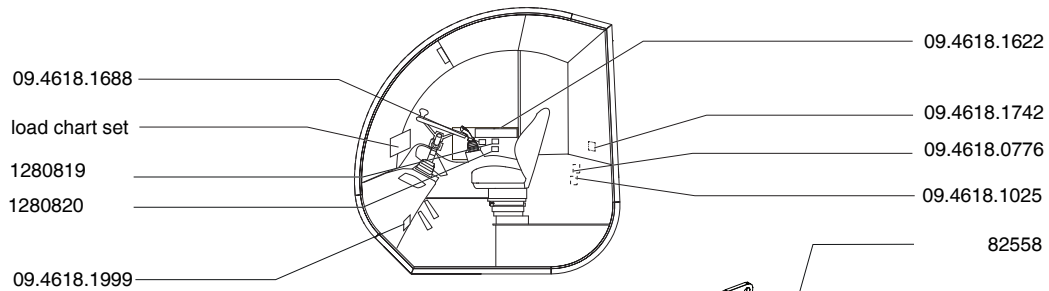
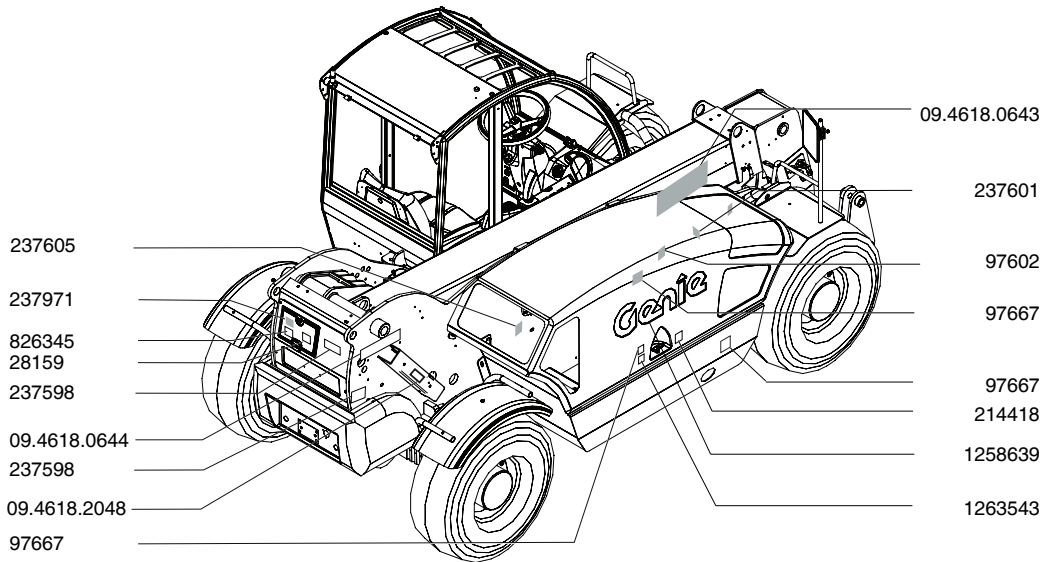

■ Shading indicates decal is hidden from view, i.e. under covers

# Operating Instructions



---

## Do Not Operate Unless:

- You learn and practice the principles of safe machine operation contained in this operator's manual.
  - 1 Avoid hazardous situations.
  - 2 Always perform a pre-operation inspection.
  - 3 Always perform function tests prior to use.
  - 4 Inspect the workplace.
  - 5 **Only use the machine as it was intended.**

## Fundamentals

The Operating Instructions section provides instructions for each aspect of machine operation. It is the operator's responsibility to follow all the safety rules and instructions in the operator's, safety and responsibilities manuals.

A variable reach rough terrain forklift truck is defined as a wheeled type truck designated primarily as a fork truck with a pivoted boom, which may be equipped with attachments for lifting material. Using it for any other purpose is unsafe and dangerous.

Only trained and authorized personnel should be permitted to operate a machine. If more than one operator is expected to use a machine at different times in the same work shift, they must all be qualified operators and are all expected to follow all safety rules and instructions in the operator's, safety and responsibilities manuals. That means every new operator should perform a pre-operation inspection, function tests, and a workplace inspection before using the machine.

Additionally, everyone working on or near the product also needs to be familiar with the applicable safety precautions.

# Operating Instructions

## Parking Brake

Use the parking brake switch to apply the parking brake before raising the boom or leaving the machine.

Push the bottom of the rocker switch to turn the parking brake on.

Push the top of the switch to turn the parking brake off.

## Brake Pedal

Use the brake pedal to control the machine speed and to stop the machine motion.

Push and hold the brake pedal to stop the machine.

Push and release the brake pedal to control the machine speed.

## Starting the Engine

1. Be sure the parking brake is set and the transmission control lever is in the neutral position.
2. Insert the key in the ignition switch.
3. Turn the key until the engine starts.

If the engine fails to start after 30 seconds of cranking, determine the cause and repair any malfunction. Wait 120 seconds before trying to start again.

## Starting in Cold Condition

In cold conditions, 20°F / -6°C and below, warm the engine for 5 minutes before operating to prevent hydraulic system damage.

In extreme cold conditions, 0°F / -18°C and below, machines should be equipped with optional cold start kits. Attempting to start the engine when temperatures are below 0°F / -18°C may require the use of a booster battery.

## Steer Select

Always position all wheels in line with the machine before switching the steering mode.

Do not realign the wheels while driving.

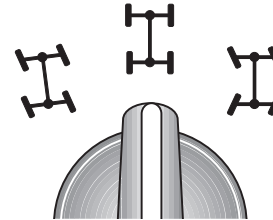

## Emergency Exit (if equipped)

Lift up the two levers and remove the wing nuts securing the levers to the frame

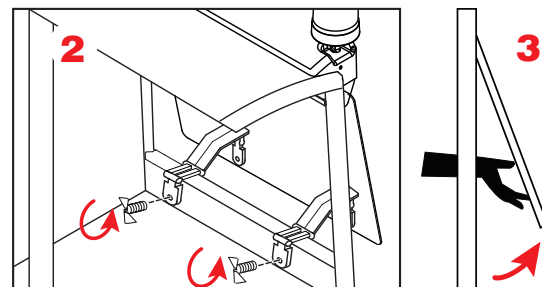
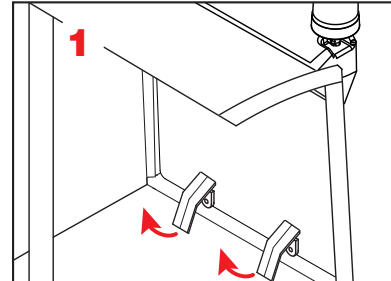

# Operating Instructions

## Transmission Control

Use the transmission control lever to control the direction of machine travel.

Step on the service brake pedal before putting the transmission into gear.

To drive forward, move the transmission control lever toward you and move it up.

To drive in reverse, move the transmission control lever toward you and move it down: the back-up alarm sounds and the rear working light turns on (if equipped).

To return to neutral, move the transmission control lever to the center position.

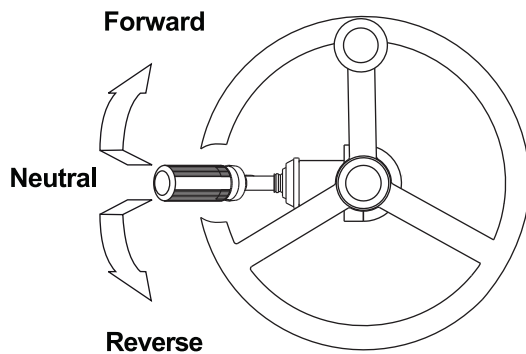

## Operating Instructions

### Transporting a Load

Center the load on the forks. Position the load so that it is completely against the back of the fork frame.

The load should be kept as low to the ground as possible while traveling. Always move a loaded machine with the boom angle indicator at 0 degrees or less.

Tilt the forks back slightly to help keep the load secure.

Always bring the machine to a complete stop before applying the parking brake.

### Raising and Placing a Load

The load chart in the cab shows the operating limits of a properly maintained and operated machine. To use the load chart, the operator must know the weight of the load, its load center and how far out and up it is to be placed.

This machine has more than one load chart. Be sure you are using the load chart that corresponds to the attachment on the machine.

If you determine that the weight of the load cannot be placed at the height and angle you want, these options can be used:

- 1 Move the machine closer to the loading or pick point so that the weight of the load will meet the load chart specifications.
- 2 Divide the load into smaller pieces so that each piece meets the load chart specifications.
- 3 Obtain a larger machine capable of handling the load within specifications.

### Placing the load

- 1 Travel to the desired work site and carefully stop the machine.
- 2 Put the transmission in neutral.
- 3 Apply the parking brake.

## Operating Instructions

- 4 Gradually move the controller to raise and extend the boom to the required height.

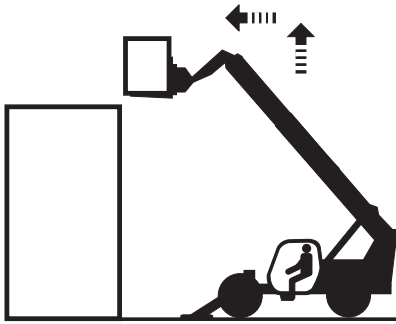
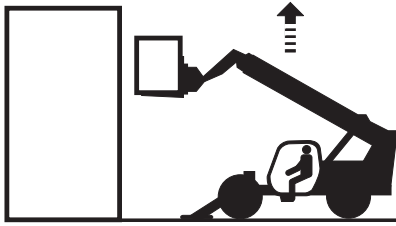

- 5 Gradually move the controller to lower and extend the boom into final position. Lower the load until the weight is completely off the forks. Do not apply a downward force with the forks.

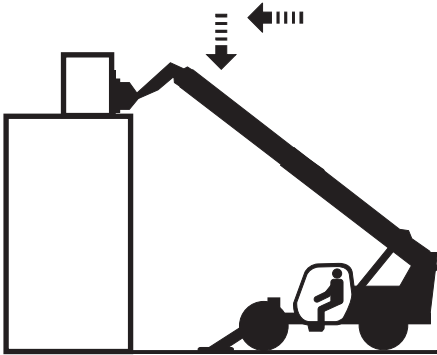

- 6 Gradually move the controller to raise and retract the boom. This will bring the forks out of the load.

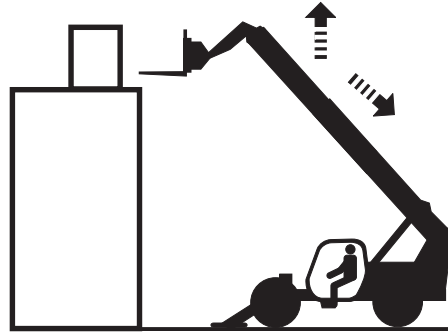

- 7 When the forks are clear of the load and the structure, the boom can be lowered and retracted.

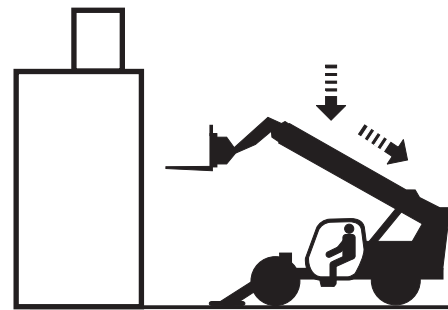



# Operating Instructions

## Controller movements

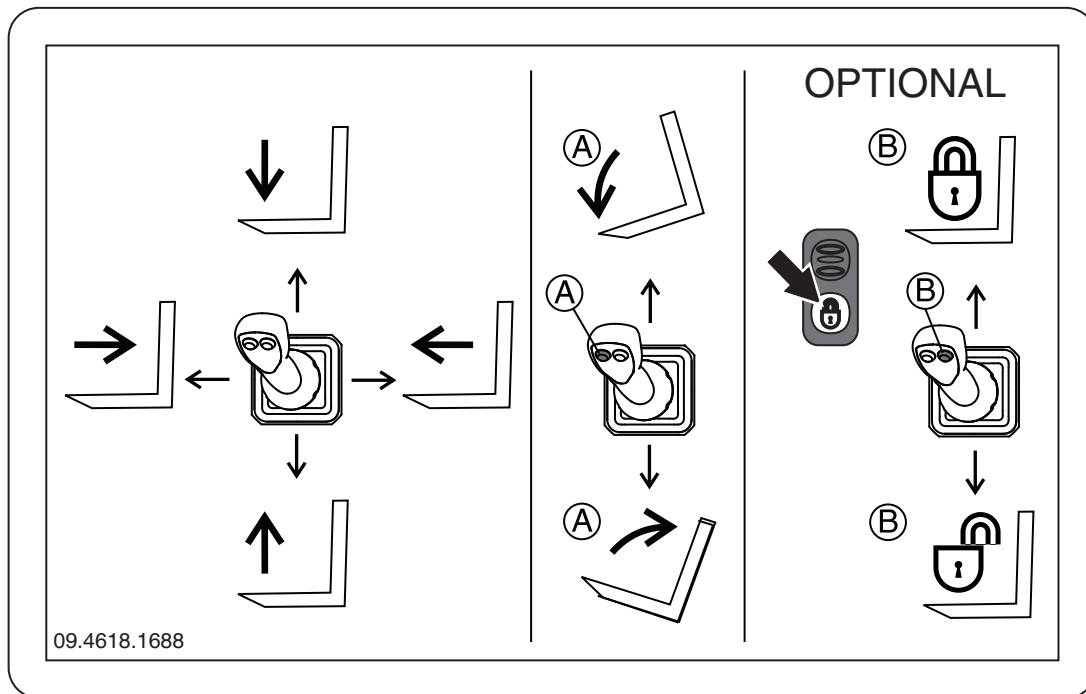

Control handle only

Control handle only with yellow thumb switch (A)

OPTIONAL Control handle only with red thumb switch (B)

# Operating Instructions

## Quick Attach Instructions

### Version with mechanical locking

- 1 Drive to the place where you will release the mounted attachment (when possible, a solid and sheltered site).
- 2 Disconnect the quick connectors of the attachment (if any).
- 3 Pull out the mechanical pin locking the attachment after removing the safety split-pin at its end.
- 4 Rest the attachment flat on the ground.
- 5 Pitch the attachment holding frame forward and lower the boom to release the attachment upper lock.
- 6 Move back with the machine and drive to the new attachment to be coupled.
- 7 Hold the frame pitched forward and hook the upper lock of the new attachment.
- 8 Retract and raise the attachment a small distance. It will center automatically on the quick coupling frame.
- 9 Refit mechanical locking pin fixing it with its safety split-pin.
- 10 Re-couple the connectors of the attachment (if any).

### Version with hydraulic locking (optional)

1. Drive to the place where you will release the mounted attachment (when possible, a solid and sheltered site).
2. Disconnect the quick connectors of the attachment (if any).
3. Rest the attachment flat on the ground.
4. Press the Lock/Unlock Enabling Switch and keep it pressed up to the end of Step 5.
5. Free the attachment using the control lever.
6. Pitch the attachment holding frame forward and lower the boom to release the attachment upper lock.
7. Move back with the machine and drive to the new attachment to be coupled.
8. Hold the frame pitched forward and hook the upper lock of the new attachment.
9. Retract and raise the attachment a small distance. It will center automatically on the quick coupling frame.
10. Coupling the attachment using the control lever together with the dashboard Lock/Unlock Enabling Switch.
11. Re-couple the connectors of the attachment (if any).

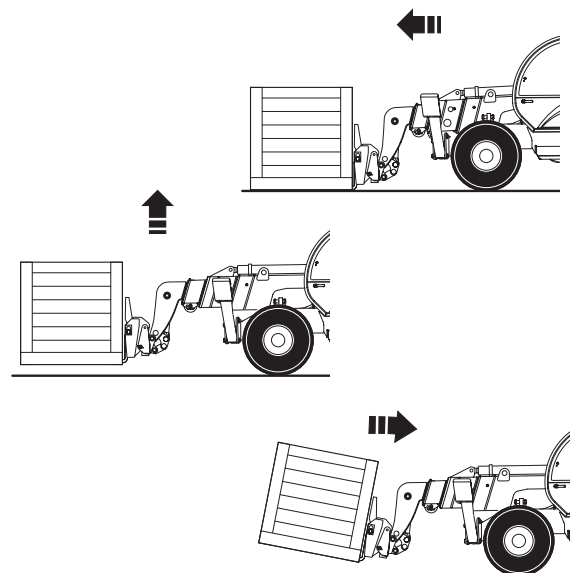

# Operating Instructions

## Engine Condition Indicator

If the Engine Alert indicator light and/or the Engine Critical Fault indicator light switch on, contact service personnel.

## After Each Use

- 1 Select a safe parking location—firm level surface, clear of obstruction and traffic.
- 2 Retract and lower the boom to the stowed position.
- 3 Move the transmission control lever to neutral.
- 4 Set the parking brake.
- 5 Turn the key switch to the off position and remove the key to secure from unauthorized use.
- 6 Chock the wheels.

## Jump Starting the Machine

Jump starting at the battery or battery replacement is required when the battery is discharged to the point where the battery will not crank the starter.

**Never** jump start the machine directly to the starter or the starter solenoid. Serious injury or death could result from the machine moving forward or backward.

To avoid personal injury when jump starting with another machine, be certain that the machines are not touching.

Never jump start a frozen battery as it will explode.

Keep sparks and flames away from the battery. Lead acid batteries generate explosive gases when charging. Wear safety glasses when working near batteries.

The booster battery must be 12V. The machine used for jump starting must have a negative ground electrical system.

### To jump start the machine

- 1 Connect the positive (+) jumper cable to the positive (+) post of the discharged battery.
- 2 Connect the other end of the same jumper cable to the positive (+) post of the booster battery.
- 3 Connect one end of the second jumper cable to the negative (-) post of the booster battery.
- 4 Make the final cable connection to the engine block or the furthest ground point away from the battery.
- 5 Start the engine.

## Operating Instructions

### ⚠ Driving on a slope

When the machine is loaded, always travel with the load uphill. When the machine is unloaded, travel with the forks or attachment downhill.

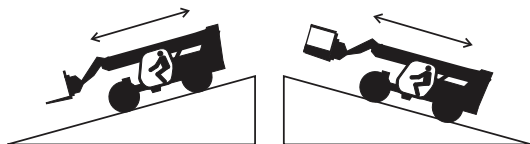

On steep terrain, drive only up and down hill, and always keep the machine in gear. Do not turn across slope when machine is traveling up or down a slope.

Limit travel path and speed according to the condition of the ground surface, traction, slope, location of personnel and any other factors which may create a hazard. Never drive the machine unless the mast and equipment are in their proper travel position.

Whether a machine will tip over during dynamic machine operation involves many variables that need to be considered. Among these are pavement/ground conditions, stability and slope, as well as machine equipment, operator skill, load position, tire inflation, machine speed, etc.

Additionally, tip over of a machine is dependent in large part upon operator inputs such as the speed and smoothness of the operation as well as the position of the attachment and its load.

Construction sites and roads will frequently change slope from place to place, can be hard and soft, and change due to the construction activities and weather.

Operators should be properly trained and use their best judgment and experience to take the necessary precautions to prevent tip over. Operators must assess the jobsite variables and avoid exceeding the machine's (or operator's) capabilities for terrain and conditions.

### ⚠ Rear Proximity Alarm

The system is designed to supplement other safety practices and systems such as signal person and mirrors, and is not intended to be used as the sole method of collision avoidance. It should be used in conjunction with established safety programs and procedures to augment the safe operation of the telehandler. The operator is always the first line of defense when safely operating the telehandler and should always use direct line of sight and indirect visual methods, like mirrors, to identify and avoid obstacles and collision hazards.

The system detects both moving and stationary objects in a pre-defined coverage area (see the specifications and chart in the back of this manual) and reports the distance of the closest object via visual range indicators and an audible signal to the operator.

The system can detect most objects within the detection zone. However, there are some instances where objects can go undetected. Obstacle size, shape, relative location, and composition are all factors determining if, when and where an object is detected. The system operates by transmitting a pulse of very low power electromagnetic energy. Any energy that strikes an object reflects a certain amount of this energy back to the sensor. If the returned energy is of sufficient magnitude, it is used to indicate object presence and determine the object's distance. While the system can resolve multiple objects, only the object closest to the vehicle is reported to the display since it represents the nearest collision hazard.

Always look in the direction of travel. When the rear proximity alarm sounds, bring the machine to a controlled stop and verify the location of the obstacle. Only proceed when the obstacle is clear of the travel path.

Display range indications illuminate to give a relative distance measurement to the closest detected object. LEDs operate from left to right, with a closer object resulting in more LEDs illuminated.

# Operating Instructions

## Moving a disabled machine

Tow the machine only when no alternative is possible, since this operation may result in serious damage to the transmission. When possible, repair the machine on site.

When the machine must be towed:

1. Disable the parking brake.
2. Set the transmission to neutral.
3. Select the two-wheel steer.
4. Connect a rigid draw bar to one of the two tie down points present on the front axle.
5. When possible, start the engine and use the hydraulic drive and the braking system.
6. Tow the machine for short distances and at low speed (less than 5 km/h).

### Disabling the parking brake

⚠ Use the wheel chokes on all wheels to prevent the vehicle moving once the parking brake is disabled.

⚠ Lock with mechanical system all wheels to prevent the vehicle moving once the parking brake is disabled.

To unlock the negative brake of a faulty machine:

1. On both sides unscrew the nuts (5).
2. Screw in the brake release bolts (6a) and (6b), 1/2 turn at a time, in sequence, until the torque drops off sharply (the wheels are free).

⚠ Clear the area of any personnel before remove the locking from each of the four tires and tow the vehicle to a suitable location.

### Enabling the parking brake

⚠ Use wheel chokes on all wheels to prevent the vehicle from moving before executing any operation.

⚠ Lock with mechanical system all four wheels to prevent the vehicle from moving before execute any operation.

To re-activate the negative brake:

1. Apply a 20÷25 bar pressure to the parking brake release port (B).
2. Unscrew brake release screws (6) on both sides
3. Adjust the screws (6) to  $19.5 \pm 1$  mm. Apply the B2 sealant on nuts (5) and tighten them to 45 Nm.
4. Release the pressure at the brakes port (B).

The parking brakes are now re-activated and the wheels are locked.

Clear the area of any personnel and verify that parking brake works properly.

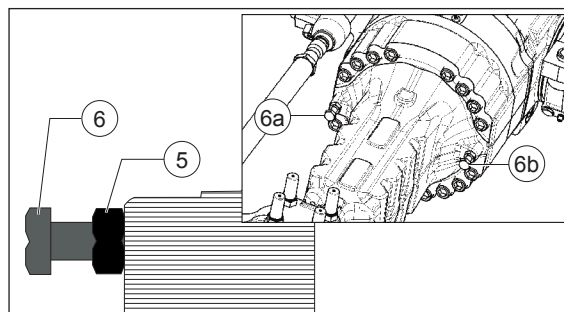

## Transport and Lifting Instructions



### Observe and Obey:

- Genie provides this securement information as a recommendation. Drivers are solely responsible for making sure machines are properly secured and the correct trailer is selected pursuant to US Department of Transportation regulations, other localized regulations, and their company policy.
  - Genie customers needing to containerize any lift or Genie product should source a qualified freight forwarder with expertise in preparing, loading and securing construction and lifting equipment for international shipment.
  - Only qualified operators should move the machine on or off the truck.
  - The transport vehicle must be parked on a level surface.
  - The transport vehicle must be secured to prevent rolling while the machine is being loaded.
- Before loading for transport, make sure the deck, ramps and machine tires are free of mud, snow and ice. Failure to do so could cause the machine to slide.
  - Be sure the vehicle capacity, loading surfaces and chains or straps are sufficient to withstand the machine weight. Genie telehandlers are very heavy relative to their size. See the serial label for the machine weight. See the Inspections section for the serial label location.

## Transport and Lifting Instructions

### Securing to Truck or Trailer for Transit

Turn the key switch to the off position and remove the key before transporting.

Inspect the entire machine for loose or unsecured items.

Be sure the door and the door windows are latched and secured (if equipped).

Prior to loading, level the telehandler and retract the boom.

Use a spotter to load and unload the telehandler. Keep the boom as low as possible when loading and unloading.

Set the parking brake.

### Securing the Chassis

Use chains of ample load capacity.

Use a minimum of 4 chains. There are 4 tie down points on the chassis, two in the front and two in the rear of the machine.

Fully lower the forks or attachment onto the truck bed. Secure the forks or attachment with a suitable strap or chain to prevent movement.

Adjust the rigging to prevent damage to the chains.

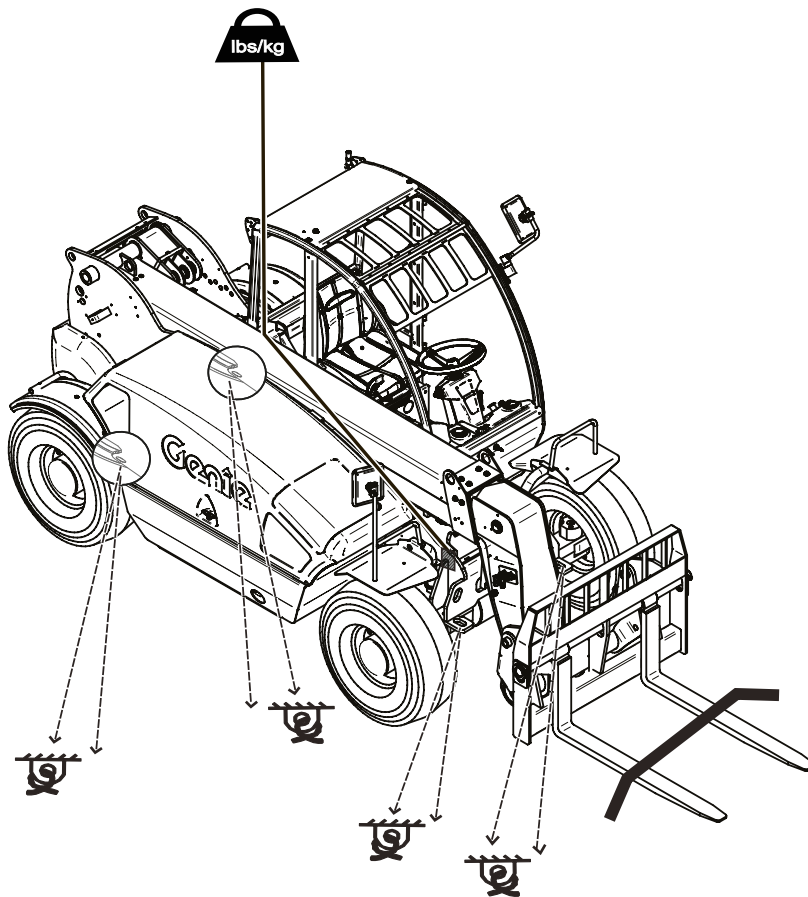

# Transport and Lifting Instructions



## Observe and Obey:

- ☑ Only qualified riggers should rig the machine.
- ☑ Only certified crane operators should lift the machine and only in accordance with the applicable crane regulations.
- ☑ Be sure the crane capacity, loading surfaces and straps or lines are sufficient to withstand the machine weight. See the serial label for the machine weight.

## Lifting Instructions

Fully lower and retract the boom.

Determine the center of gravity of your machine using the picture on this page.

Remove all loose items on the machine.

Attach the rigging only to the designated lifting points on the machine.

Adjust the rigging to prevent damage to the machine and to keep the machine level.

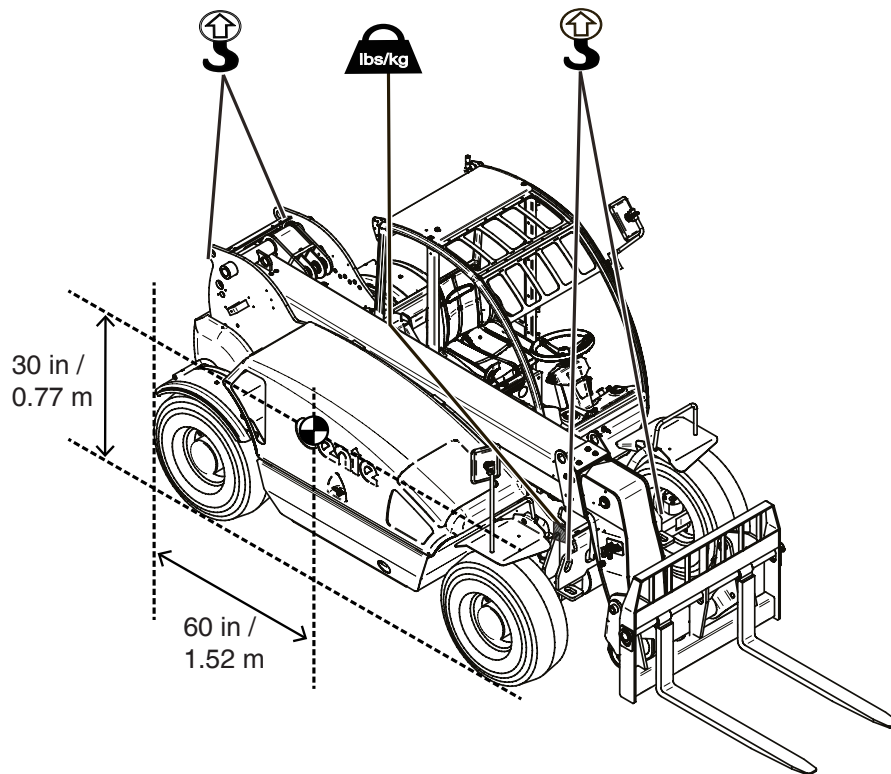



# Maintenance



## Observe and Obey:

- ☑ Only routine maintenance items specified in this manual shall be performed by the operator.
- ☑ Scheduled maintenance inspections shall be completed by qualified service technicians, according to the manufacturer’s specifications and the requirements specified in the responsibilities manual.

## Maintenance Symbols Legend

The following symbols have been used in this manual to help communicate the intent of the instructions. When one or more of the symbols appear at the beginning of a maintenance procedure, it conveys the meaning below.



Indicates that tools will be required to perform this procedure.



Indicates that new parts will be required to perform this procedure.



Indicates that a cold engine will be required to perform this procedure.

## Diesel Fuel Requirements

Satisfactory engine performance is dependent on the use of a good quality fuel. The use of a good quality fuel will give the following result: long engine life and acceptable exhaust emissions levels.

The Tier 4 Final engine must be operated using only Ultra Low Sulfur Fuel. The sulphur content of this fuel must be lower than 15 PPM.

<b>Tank</b>	15.9 gal	60 L
-------------	----------	------

### Deutz 2.9 Tier 4 Final

Fuel Type	Ultra Low Sulfur Fuel (ULSD)
-----------	------------------------------

### Deutz 2.9 Tier 4 Interim

Fuel Type	Diesel
-----------	--------

## Maintenance

### Check the Engine Oil Level



Maintaining the proper engine oil level is essential to good engine performance and service life. Operating the machine with an improper oil level can damage engine components.

Note: Check the oil level with the engine off and on a level surface.

1 Check the oil level dipstick. Add oil as needed.

---

#### Deutz 2.9 Tier 4 Interim

Oil type	SHELL RIMULA R4 L 15W-40
----------	--------------------------

---

#### Deutz 2.9 Tier 4 Final

Oil type	SHELL RIMULA R4 L 15W-40
----------	--------------------------

### Check the Hydraulic Oil Level



Maintaining the hydraulic oil at the proper level is essential to machine operation. Improper hydraulic oil levels can damage hydraulic components. Daily checks allow the inspector to identify changes in oil level that might indicate the presence of hydraulic system problems.

- 1 Be sure that the engine is off and the boom is in the stowed position.
- 2 Visually inspect the sight gauge located behind the cab.
  - ⊙ Result: The hydraulic oil level should be halfway in the sight gauge.
- 3 Add oil as needed. Do not overfill.

---

#### Hydraulic oil specifications

Hydraulic Oil type

CHEVRON RANDO HD EQUIVALENT

---

## Maintenance

### Check the Engine Coolant Level - Liquid Cooled Models



Maintaining the engine coolant at the proper level is essential to engine service life. Improper coolant level will affect the engine's cooling capability and damage engine components. Daily checks will allow the inspector to identify changes in coolant level that might indicate cooling system problems.

- 1 Visually inspect the sight gauge located on the top side of the radiator.
- ⊙ Result: The fluid level should be halfway in the sight gauge.
- ⚠ **Bodily Injury Hazard.** Fluids in the radiator are under pressure and extremely hot. Use caution when removing cap and adding fluids.

### Check the Tire Pressure



- ⚠ **Tip-over hazard.** An over-inflated tire can explode which may compromise machine stability and cause the machine to tip over.
- ⚠ **Tip-over hazard.** The use of temporary flat tire repair products may lead to tire failure which could compromise machine stability and cause the machine to tip over.
- ⚠ **Bodily injury hazard.** An over-inflated tire can explode and may cause death or serious injury.

Note: This procedure does not need to be performed on machines equipped with foam-filled tires.

- 1 Check each tire with an air pressure gauge. Add air as needed.

---

<b>Tire pressure</b>	65 psi	<b>4.5</b> bar
----------------------	--------	----------------

---

### Check Mirrors

Maintaining the indirect visual aids is essential to workplace visibility.

1. Visually inspect all mirrors to ensure they are working properly and clean and free from debris.

# Maintenance

## Check the Battery



Proper battery condition is essential to good machine performance and operational safety. Improper fluid levels or damaged cables and connections can result in component damage and hazardous conditions.

- ⚠ **Electrocution hazard.** Contact with hot or live circuits may result in death or serious injury. Remove all rings, watches and other jewelry.
  - ⚠ **Bodily injury hazard.** Batteries contain acid. Avoid spilling or contacting battery acid. Neutralize battery acid spills with baking soda and water.
- 1 Put on protective clothing and eye wear.
  - 2 Be sure that the battery cable connections are tight and free of corrosion.
  - 3 Be sure that the battery hold-down brackets are in place and secure.

Note: Adding terminal protectors and a corrosion preventative sealant will help eliminate the corrosion on the battery terminals and cables.

## Scheduled Maintenance

Maintenance performed quarterly, annually and every two years must be completed by a person trained and qualified to perform maintenance on this machine according to the procedures found in the service manual for this machine.

Machines that have been out of service for more than three months must receive the quarterly inspection before they are put back into service.

## Attachments

### ▲ Suspended Load Hazards

#### Work Area Safety

#### General Safety

Do not lift a suspended load without first understanding the local, state, federal, or provincial rules, standards and regulations related to the activity. In the USA requirements are set forth in ANSI/ITSDF B56.6 and OSHA 29 CFR 1926.1400-1442. Additional rules, standards and regulations may apply. Additional training may be required.

If a telehandler must be used to transport a suspended load, the following precautions for the protection of the operator shall be taken.

Read, understand and obey all warnings and instructions provided with the attachment that is approved for suspending loads.

Only a properly designed, tested and approved attachment shall be used to carry a suspended load.

The telehandler load charts are designed for loads where the load center is stationary. As a suspended load moves, the load center can change. As a result, extreme caution in transporting and lifting, or placing the load must be observed to minimize the potential for the load to move.

### Overturning Hazards

Do not lift a suspended load without the proper and legible load capacity chart for the attachment/telehandler combination you are using.

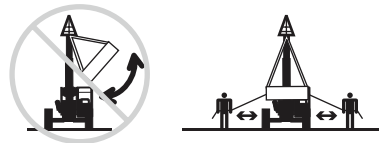

Do not permit the load to swing freely. Always properly tether loads to restrict movement. Driving across grades, sudden starts, stops, and turns can cause the load to swing and create a hazard if not externally stabilized.

Keep the boom retracted as much as practical.

Do not lift suspended loads when wind speeds can cause an unsafe situation.

All movements of the load must be accomplished gradually and at the slowest practical speed to prevent the load from swinging.

Keep the heavy part of the load closest to the attachment.

Never drag or pull a load sideways.

Only lift a load vertically; do not pull a load horizontally as it could cause excessive swinging of the load.

The weight of all rigging (slings, shackles etc.) must be included as part of the load.

## Attachments

Identify the proper lifting points of the load, taking into consideration the center of gravity and load stability.

Do not attempt to use the telehandler frame-leveling to compensate for a swinging load or to adjust the load after it has been raised.

Do not try to move fixed or obstructed loads.

Do not leave the telehandler unattended with a suspended load.

Keep the boom and load as low as practical while maintaining visibility in the direction of travel.

Do not exceed walking speed (2 mph / 3.2 km/h) with a suspended load.

Start, travel, turn and stop slowly to prevent the load from becoming unstable or swinging.

Do not use any controls to re-position the load when traveling. Come to a gradual and complete stop before attempting to re-position the load.

Do not attempt to cross inclines as the load center will move towards the tipping line, thereby reducing stability.

Only climb or descend inclines with extreme care as the load center will move towards the tipping line, thereby reducing stability.

Do not park on a slope.

## Fall Hazards

Do not lift or suspend personnel.

## Collision Hazards

Be sure that the load is clear of any adjacent obstacles before lifting.

When visibility is or could be obstructed, near or at the load placement, the operator shall use alternative or additional means to safely lift the load, such as a qualified signal person.

Signal persons must remain in constant communication (verbal or hand) and be in visual contact with the operator at all times.

## Crush Hazards

Never allow the signal person to come between the suspended load and another object (such as the telehandler itself).

## Falling Object Hazards

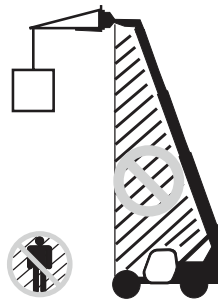

Do not raise the load into the fall zone shown.

Do not operate the machine while people are under the load or in the fall zone.

Do not suspend loads using slings or chains from the forks or fork carriage.

Avoid lifting double tiered loads.

## Attachments

### Lifting a Suspended Load

Verify that the landing point is level and can safely support the load.

Properly secure the attachment to the telehandler

Level the frame on the telehandler.

Rig the load as outlined in OSHA 29 CFR 1926.1401, 1926.1404, and 1926.1425, keeping the heaviest part of the load as close to the attachment as practical.

Tether the load to restrict movement.

Ask a signal person to assist with lifting the load if visibility will be obstructed at the point of operation.

Make sure that the signal person remains in constant communication and is in visual contact at all times with the operator.

With the boom retracted as far as practical, slowly and gradually raise the boom and load, making sure to keep the load and boom as close to the ground as practical.

Be sure that all boom and attachment movements are performed as slow as practical to avoid swinging of the load.

### Traveling

Be sure that the path of travel is level and capable of supporting the telehandler with its load.

Keep the boom, and load, as low as practical while maintaining visibility in the direction of travel.

Ask a signal person to assist with your travel if visibility will be obstructed in the direction of travel.

Crush or Collision Hazard. Make sure that the signal person remains in constant communication and be in visual contact at all times with the operator.

Only make adjustments to the load after bringing the telehandler to a complete stop.

Start, stop, travel and turn slowly to prevent the load from becoming unstable or swinging.

Do not travel faster than walking speed (<2 mph / 3.2 km/h).

## Attachments

### Placing the Load

Ask a signal person to assist with placing the load if visibility will be obstructed at the point of operation.

Make sure that the signal person remains in constant communication and be in visual contact at all times with the operator.

Come to a complete stop near the landing point.

Set the parking brake and place the transmission into neutral.

Slowly, and gradually, place the load over the landing point and lower the load until it is safely supported.

Once the load has been landed, continue to lower the boom until the rigging and tethers can be removed.

### Signal Person (from 1926.1419)

Per OSHA CFR 1926.1419, a signal person is required when:

The point of operation, meaning the load travel or the area near or at load placement, is not in full view of the operator.

When the equipment is traveling, the view in the direction of travel is obstructed.

Due to site specific safety concerns, either the operator or the person handling the load determines that it is necessary.











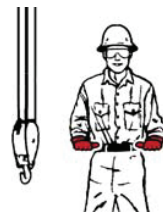

Signal persons must remain in constant communication (verbal or hand) and be in visual contact with the operator at all times.

When using hand signals, follow the requirements set forth in OSHA CFR 1926.1419-1926.1422.

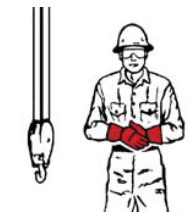
The hand signal chart below may be used in place of the Standard Method in Appendix A of Subpart CC of Part OSHA CFR 1926.

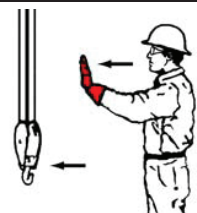

# Attachments

 <p><b>STOP.</b> With arm extended horizontally to the side, palm down, arm is swung back and forth.</p>	 <p><b>EMERGENCY STOP.</b> With both arms extended horizontally to the side, palms down, arms are swung back and forth.</p>		 <p><b>HOIST.</b> With upper arm extended to the side, forearm and index finger pointing straight up, hand and finger make small circles.</p>	 <p><b>RAISE BOOM.</b> With arm extended horizontally to the side, thumb points up with other fingers closed.</p>
 <p><b>SWING.</b> With arm extended horizontally, index finger points in direction that boom is to swing.</p>	 <p><b>RETRACT TELESCOPING BOOM.</b> With hands to the front at waist level, thumbs point at each other with other fingers closed.</p>	 <p><b>RAISE THE BOOM AND LOWER THE LOAD.</b> With arm extended horizontally to the side and thumb pointing up, fingers open and close while load movement is desired.</p>	 <p><b>DOG EVERYTHING.</b> Hands held together at waist level.</p>	 <p><b>LOWER.</b> With arm and index finger pointing down, hand and finger make small circles.</p>
 <p><b>LOWER BOOM.</b> With arm extended horizontally to the side, thumb points down with other fingers closed.</p>	 <p><b>EXTENDED TELESCOPING BOOM.</b> With hands to the front at waist level, thumbs point outward with other fingers closed.</p>	 <p><b>TRAVEL/TOWER TRAVEL.</b> With all fingers pointing up, arm is extended horizontally out and back to make a pushing motion in the direction of travel.</p>	 <p><b>LOWER THE BOOM AND RAISE THE LOAD.</b> With arm extended horizontally to the side and thumb pointing down, fingers open and close while load movement is desired.</p>	 <p><b>MOVE SLOWLY.</b> A hand is placed in front of the hand that is giving the action signal.</p>

## Attachments

### ▲ Suspended Load Hazards

Rigger Requirements (from OSHA CFR 1926.404)

When employees are engaged in hooking, unhooking, or guiding the load, or in the initial connection of a load to a component or structure and are within the fall zone, all of the following criteria must be met:

The materials being hoisted must be rigged to prevent unintentional displacement.

Hooks with self-closing latches or their equivalent must be used. Exception: "J" hooks are permitted to be used for setting wooden trusses.

The materials must be rigged by a qualified rigger.

## Specifications

<b>GTH-5519</b>		
Height, stowed	6 ft 4 in	1,92 m
Length, stowed, without forks	12 ft 2 in	3,70 m
Width, standard tires	5 ft 11 in	1,81 m
Wheelbase	7 ft 9 in	2,36 m
Ground clearance, center	1 ft 1 in	0,33 m
Ground clearance, axle	10 in	0,25 m
Weight	10,360 lbs	4,700 kg
Working fork height, maximum	19 ft	5,79 m
Horizontal reach maximum	11 ft	3,35 m
Reach at maximum height	2 ft	0,60 m
Lift capacity, maximum height with 24 in / 61 cm load center	4,400 lbs	1,995 kg
Lift capacity, maximum reach with 24 in / 61 cm load center	2,000 lbs	907 kg
Maximum lift capacity	5,500 lbs	2,495 kg
Drive speed, maximum,	16 mph	26 km/h
Tire size	12 x 16.5 in , 10 ply	
Turning radius, outside, 2 wheel steer	18 ft 8 in	5,70 m
Turning radius, outside, 4 wheel steer	10 ft 7 in	3,23 m
Fuel tank capacity	15.9 gal	60 L
Maximum grade	50 %	50 %
Horn sound level, manufacturer's rating	110 dB	110 dB
Backup alarm sound level, manufacturer's rating	95 dB	95 dB
<b>Floor loading information</b>		
Tire load, maximum	7,830 lbs	3,552 kg
Occupied floor pressure	237 psf	11.36 kPa
Tire contact pressure	59 psi	448 KPa

# Specifications

## Rear proximity Sensor Range

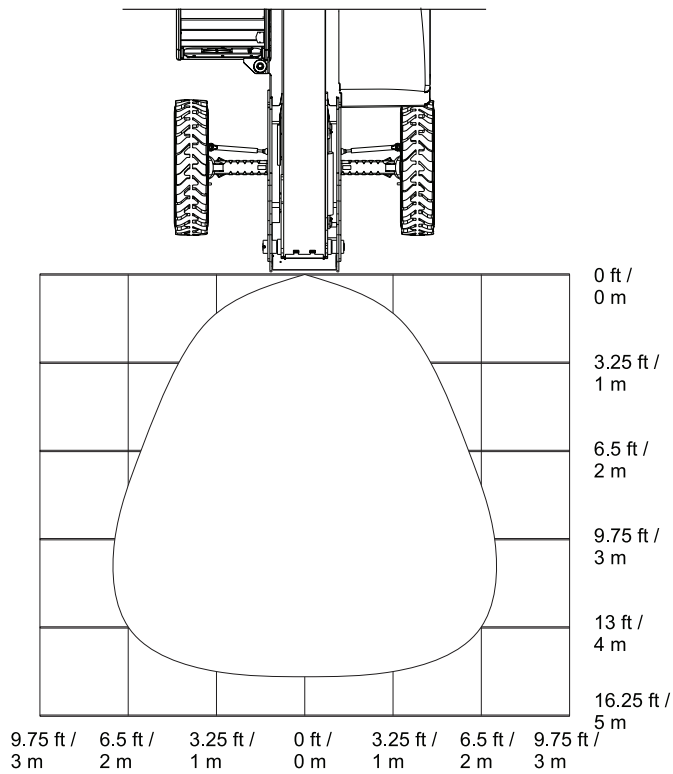

Approximate detection range. Minimum rear proximity sensor detection height is 2 ft / 0.6 m.

# Load Charts

## Load Capacity Field Calculations

Always center the load on the forks. Position the load so that it is completely against the back of the fork frame. Fork length should always be at least 2/3 the load length.

To calculate the new reduced load capacity at a load center greater than the standard 24 in / 61 cm load center, multiply the zone capacity from the load chart by the appropriate reduction factor listed in the table below. Refer to the example.

All Genie telehandler fork carriage load charts are based on a horizontal load center that is 24 in / 61 cm from the front vertical surface of the fork arm. For loads with a load center exceeding this value, refer to the table and instructions below to determine the reduced load capacity for a specific load zone. Note that this does not account for a load center that is not centered between the forks or a vertical load center exceeding 24 in / 61 cm from the top face of the fork tine. Keep the load centered on the fork carriage.

### New Horizontal Load Center, measured from front vertical surface of fork arm

	24 in / 61 cm or less	28 in / 71 cm or less	32 in / 81 cm or less	36 in / 91 cm or less	40 in / 102 cm or less	44 in / 112 cm or less	48 in / 122 cm or less	54 in / 137 cm or less
<b>Capacity Reduction Factor</b>	1.00	0.86	0.75	0.67	0.60	0.55	0.50	0.44

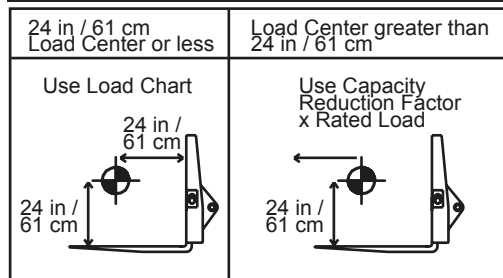

### EXAMPLE

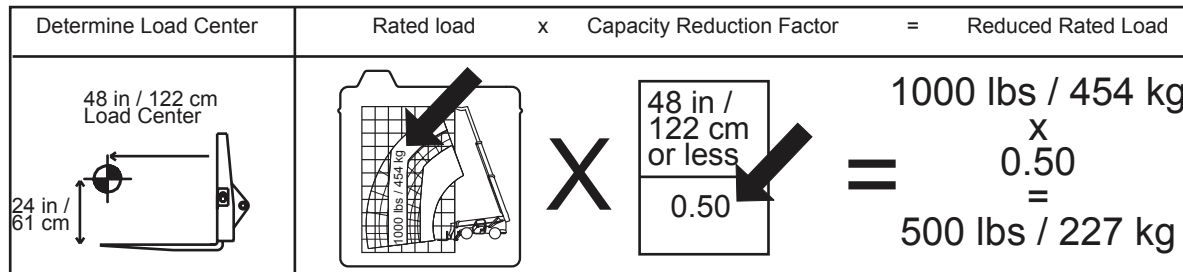

# Load Charts

## GTH-5519, Standard Carriage

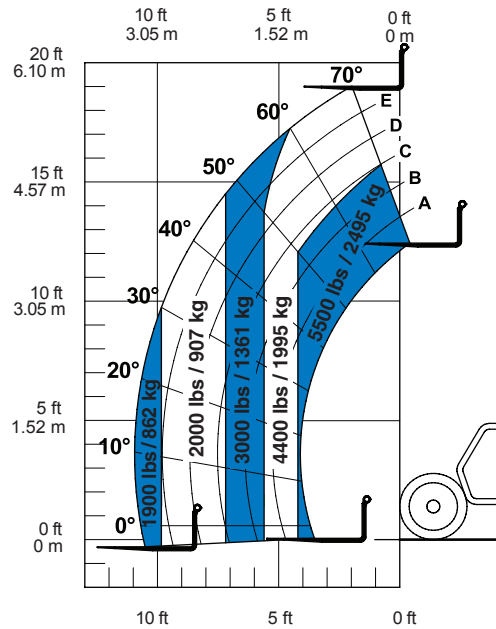

## GTH-5519, 60 and 66 inch Bucket

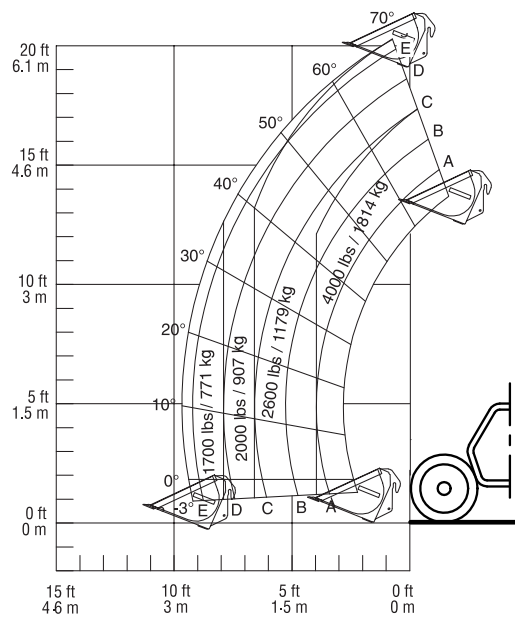

# Load Charts

## GTH-5519, Scrap Grapple Bucket

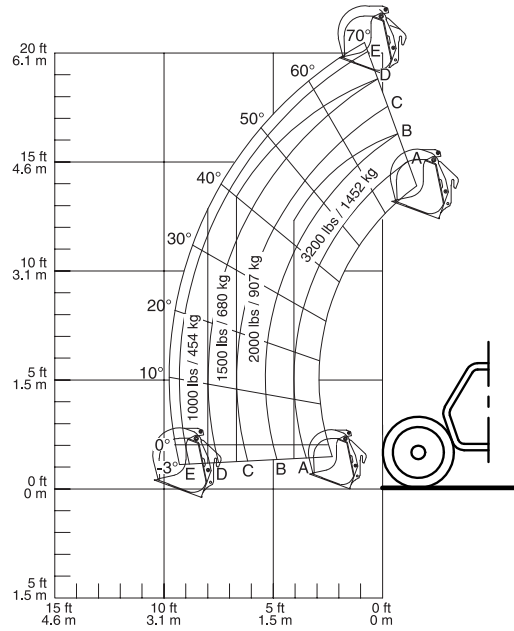

## GTH-5519, 60 inch Forks - optional 48 inch Forks - 48 inch cubing Tines

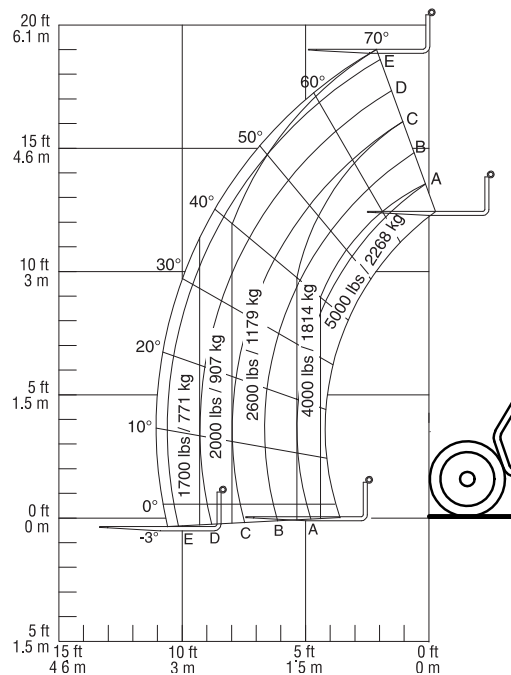

# Load Charts

## GTH-5519, Universal Attachment Adapter

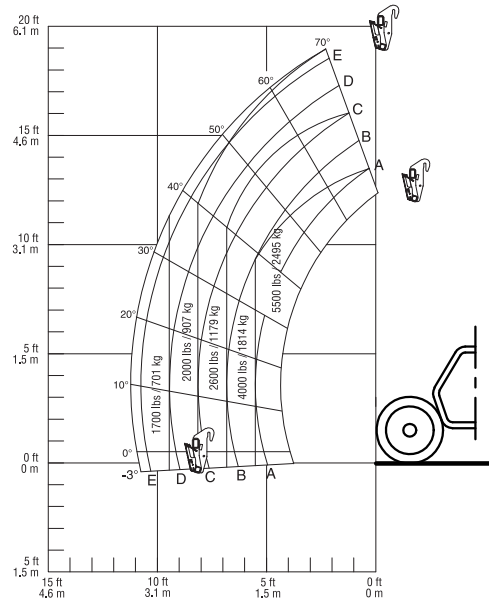

## GTH-5519, Rotating Or Side Shift Fork Carriage - Standard Fork Tines

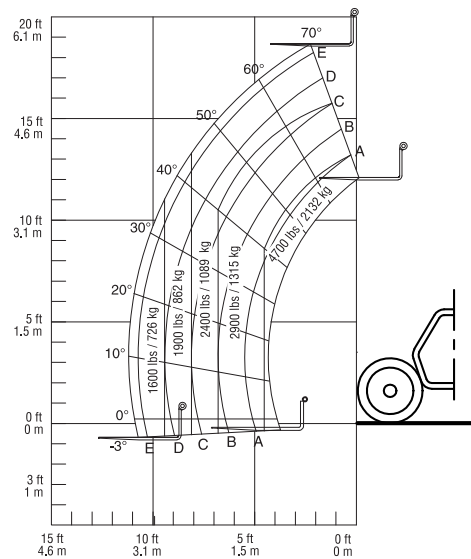



# Load Charts

## GTH-5519, Truss Boom

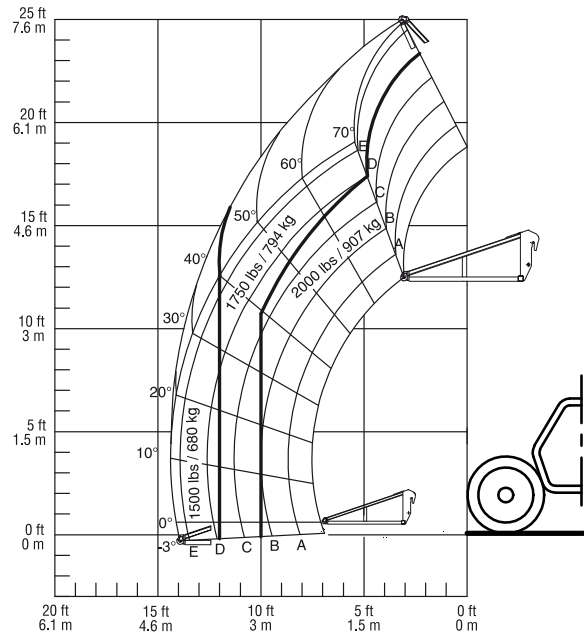

## GTH-5519, Side Shift Fork Carriage - 60" Fork Tines

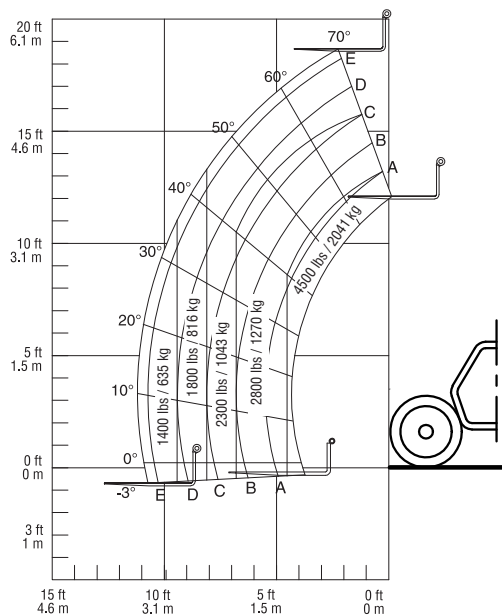

# Load Charts

## GTH-5519, Shackle

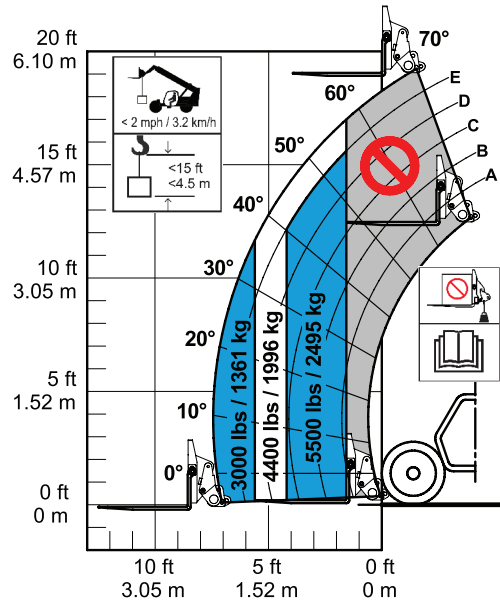

## GTH-5519, 48" Fork Positioner

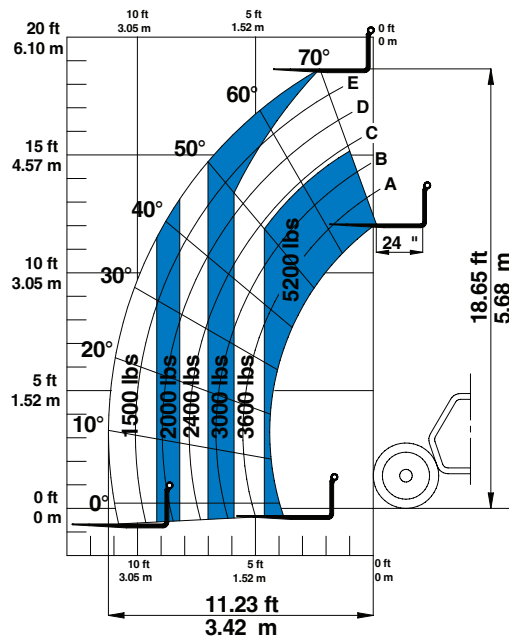

California Proposition 65



**WARNING**

Operating, servicing and maintaining this equipment, passenger vehicle or off-highway motor vehicle can expose you to chemicals including engine exhaust, carbon monoxide, phthalates, and lead, which are known to the State of California to cause cancer and birth defects or other reproductive harm. These chemicals can be emitted from or contained in other various parts and systems, fluids and some component wear by-products. To minimize exposure, avoid breathing exhaust, do not idle the engine except as necessary, service your equipment and vehicle in a well-ventilated area and wear gloves or wash your hands frequently when servicing your equipment or vehicle and after operation. For more information go to [www.P65Warnings.ca.gov/passenger-vehicle](http://www.P65Warnings.ca.gov/passenger-vehicle).

Breathing diesel engine exhaust exposes you to chemicals known to the State of California to cause cancer and birth defects or other reproductive harm.

- Always start and operate the engine in a well-ventilated area.
- If in an enclosed area, vent the exhaust to the outside.
- Do not modify or tamper with the exhaust system.
- Do not idle the engine except as necessary.

For more information go to [www.P65warnings.ca.gov/diesel](http://www.P65warnings.ca.gov/diesel).