

# USER'S INSTRUCTION MANUAL FOR PLATE COMPACTOR

MODEL: JPC-80



The purpose of this user's instruction manual is to provide safety information and operating instructions in order to protect the user from exposed danger. For your own safety, please read the safety instructions and operating instructions described in this manual thoroughly before use.

**THE INFORMATION CONTAINED IN THIS MANUAL IS BASED ON MACHINE IN PRODUCTION AT THE TIME OF PUBLICATION. NORTHERN INDUSTRIAL RESERVES THE RIGHT TO MODIFY THE EQUIPMENT WITHOUT PRIOR NOTICE.**

Please refer the following symbols as important remarks for the operation and maintenance.



Indicates the warnings which must be precisely followed in order to prevent the plate compactor from being damaged or destroyed.



Indicates the danger which must be precisely followed in order to exclude the danger of personal injury.



Indicates the important note (or information) which must be precisely perceived by the operator and the servicing personnel.



**It is USER'S RESPONSIBILITY to communicate proper information on the SAFE USE and GOOD OPERATION of this machine. Please contact your local NORTHERN industrial distributor or any of the contact address in this manual directly for further information.**

## Table of Contents

	Page
1. Safety information	3
2. Precautions	3
3. Warnings	3
4. Safety label locations	6
5. Specifications	7
6. Engine	8
7. Operation	9
8. Transportation	11
9. Storage	12
10. Periodic Maintenance Schedule	13
11. Troubleshooting	13
12. Component and Parts list	14
13. Warranty Policy	17

## 1. Safety Information

The product, Plate Compactor, is only allowed to be operated under the intended conditions of compacting ground where vibrating roller is unable to compact. It is prohibited to use it for any other purpose.

Although the product is designed with special attention to the safety, it is still the user's responsibility to read the safety information THOROUGHLY AND CAREFULLY in this manual to avoid the exposed danger before use.

The safety information in this manual alerts you to use the product safely without exposing in possible injury or damage.

Do not modify or disassemble the product.

## 2. Precautions

- 1) USERS MUST READ THE OPERATING INSTRUCTION IN THIS MANUAL CAREFULLY BEFORE USE.
- 2) KEEP THE UNAUTHORIZED, INEXPERIENCED, UNTRAINED PEOPLE AWAY FROM THIS EQUIPMENT.
- 3) MAKE SURE ALL GUARDS & SAFETY DEVICES ARE SECURLY PLACED IN THE ROTATING PARTS.
- 4) KEEP AWAY FROM THE DANAGER ZONE OF THE PLATE COMPACTOR.
- 5) DO NOT OPERATE THE PLATE COMPACTOR IN AN ENCLOSED AREA because its engine produces carbon monoxide gas.
- 6) STOP THE ENGINE COMPLETELY AS DESCRIBED IN THIS MANUAL BEFORE SERVICING, CLEANING OR ADDING FUEL.
- 7) DO NOT REFUEL THE PLATE COMPACTOR NEAR THE FLAMMABLE MATERIALS. It may cause fire.
- 8) BE CAREFUL NOT TO SPILL THE FUEL IN ENGINE, and make sure to wipe off completely if spilled before starting the engine.
- 9) DO NOT TOUCH THE MUFFLER DURING AND AFTER THE OPERATION because it generates mechanical heat which might cause heat burn.
- 10) USERS MUST BE FULLY EQUIPPED WITH APPOROVED PROTECTIE EQUIPMENTS such as safety helmet, safety gloves, safety shoes, ear plugs, safety glasses and mask and etc.
- 11) ALWAYS USE THE PROPER LIFITING CARANE TO MOVE OR LOAD THE EUQIPMENT. Lifting in person causes serious personal injury due to its heavy weight.



**FAILURES TO COMPLY WITH THE ABOVE PRECAUTIONS CAUSE SERIOUS INJURY.**

## 3. Warning

### 3.1 To avoid fatal accident

- 1) Stop the engine before refueling it and be careful not to spill the fuel during the refueling. Spilled fuel may cause fire.

- 2) Do not refuel the engine near inflammables to avoid fire.
- 3) Do not run the engine in an airtight space to avoid exhaust gas poisoning

### **3.2 To protect the operator**

- 1) When operator feels the fatigue comes from vibration, the operator must stop the machine and take a rest for a while.
- 2) An airborne noise emission level of the equipment is about 70 ~ 95 dB apart 1 m (3 feet) which requires to wear ear protectors.

### **3.3 To avoid injury or damage**

- 1) The plate compactors are Only operated by authorized persons who:
  - are aged at least 18 years.
  - are physically and mentally able to handle the plate compactor.
  - are properly trained in the operation and the maintenance of the plate compactor by the owner or its authorized representative.
  - are assessed to be able to carry out their duties reliably.
- 2) People who are drinking alcohol beverages and/or taking drugs are not allowed to operate the plate compactor.
- 3) People are not allowed to enter into the danger zone of the plate compactor.
- 4) The operator has to monitor the danger zone all the time. It is not allowed to operate if there is a person in the danger zone.
- 5) Operate the plate compactor away from other workers because cracked and bounced rock may injure other workers.
- 6) The operator has to give warning signs in case of an emergency situation.
- 7) The plate compactor can only be operated when the adequate stability is granted.
- 8) The operator has to control the running speed of the plate compactor all the time during its operation so that the plate compactor can be stopped at any time in order to avoid toppling.
- 9) The operator must turn off the plate compactor completely as described in this manual before leaving the operating position. Also, the plate compactor must be secured against unauthorized use.
- 10) The engine has to be turned off and secured against re-starting by pulling out the sparking plug socket during the maintenance and servicing.
- 11) The operator has to control the plate compactor as regards functions and obvious defects before use.
- 12) Discovered defects must be reported to supervising personnel and to the operator. Do not leave the defects which may cause serious injury of the operator.
- 13) Do not operate the plate compactor when a defect endangers the safety of the operator until the defect is rectified.
- 14) The compactor has to be checked by an expert in regular bases (at least once a year). And it must be checked

by an expert before the initial use and after the essential modification.

- 15) During the operation, the operator has to monitor other objects within a radius of 20m in case of lightning.
- 16) The compactor generates mechanical heat so do not touch the body of engine, muffler or other parts during the operation, which may cause heat burn. Please wait until it cools down to touch.
- 17) The operator must be fully equipped with safety equipment including a crash helmet, safety gloves, safety shoes, safety glasses and mask before operating the compactor.
- 18) Do not insert your hand or finger between pulley cover and engine during the operation, it may break your hand or finger.
- 19) Sprinkle the water on the working area to avoid dust before operating but NEVER operate the plate compactor if the working area is too wet because it may damage the life cycle of the product.
- 20) Do not transport the plate compactor with fuel in its fuel tank by the motor vehicle.
- 21) Do not lift the plate compactor by a person when putting on and off from vehicle. Always use a proper lifting crane to move. Lifting by person may cause personal injury due to its heavy weight.
- 22) Make sure to securely fasten the compactor for transportation. Improper fastening as holding the handle of the compactor during the transportation may cause an injury.



**Please refer to the enclosed instruction manual of engine if there is a problem or a question on engine before or during its operation.**

#### 4. Safety Label Locations

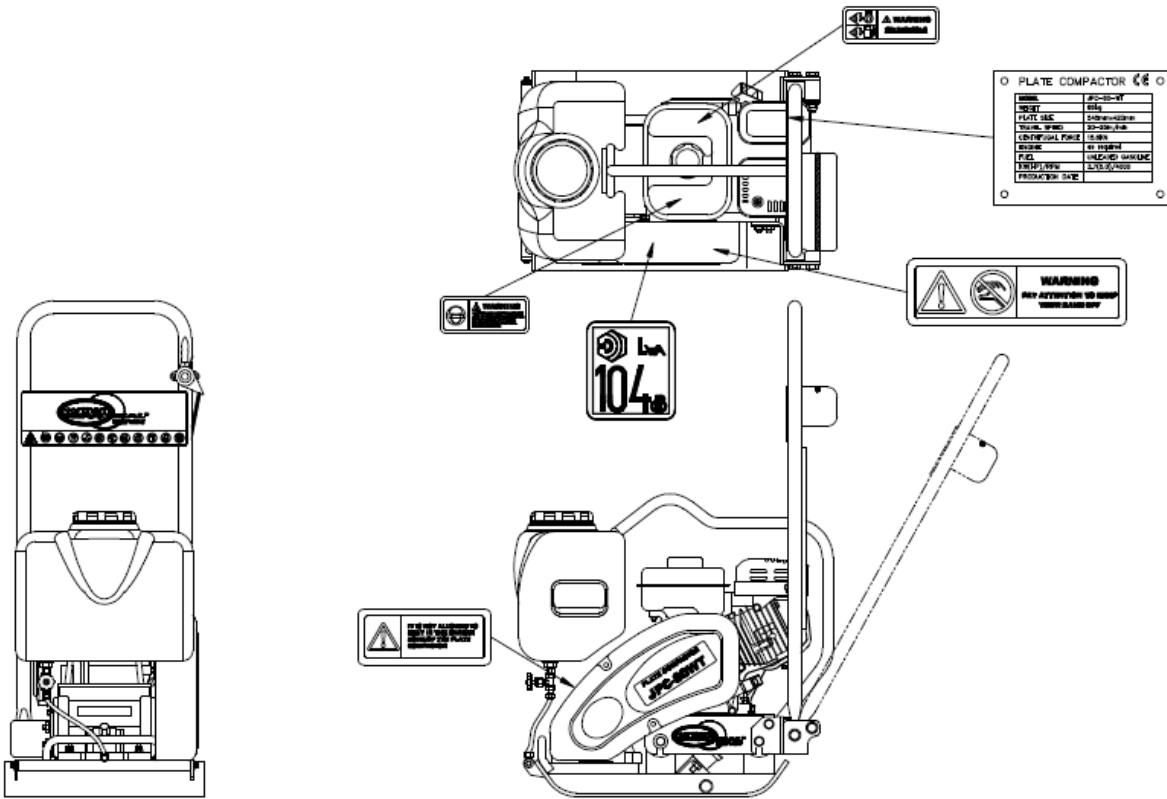

## 5. Specifications

### 5.1 Specifications

**\*\* CE CERTIFIED PRODUCT ONLY\*\***

PLATE COMPACTOR



MODEL	JPC-80
WEIGHT(kg)	86
PLATE SIZE(mm)	540 X 420
TRAVEL SPEED(m/min)	20-25
CENTRIFUGAL FORCE (kgf)	1,800
ENGINE	As required
ENGINE OIL	10W/30, 600CC
FUEL	Unleaded Gasoline
KW (HP) / RPM	4.0 ~ 4.5 (5.5 ~ 6.0)/3,600RPM
VIBRATOR OIL	SHELL OMALA #100 OR SAE10W/30 150CC
ORGIN	Made in Korea

### 5.2 Main parts of Plate Compactor

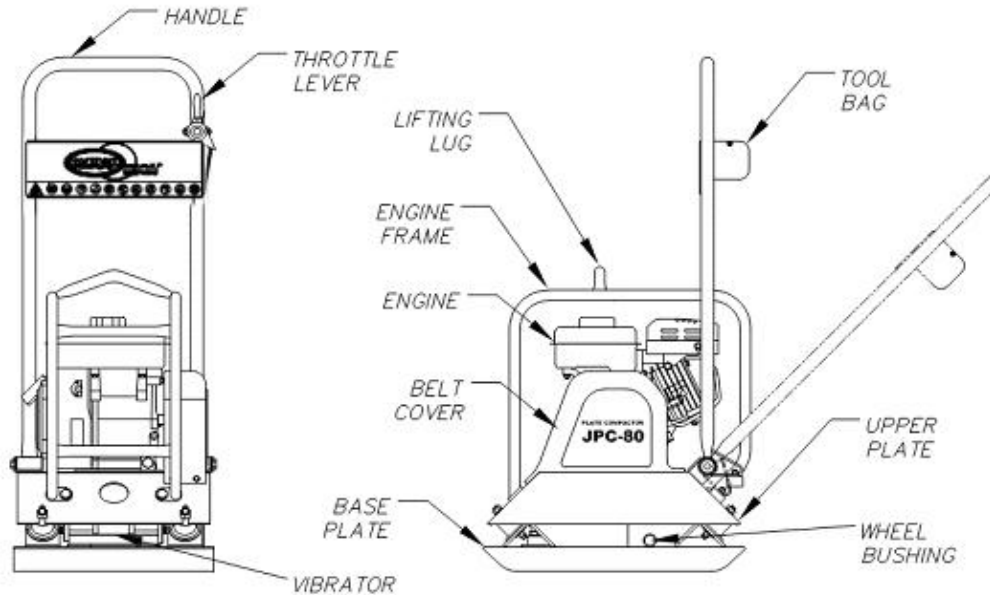



### 5.3 Outline Configuration

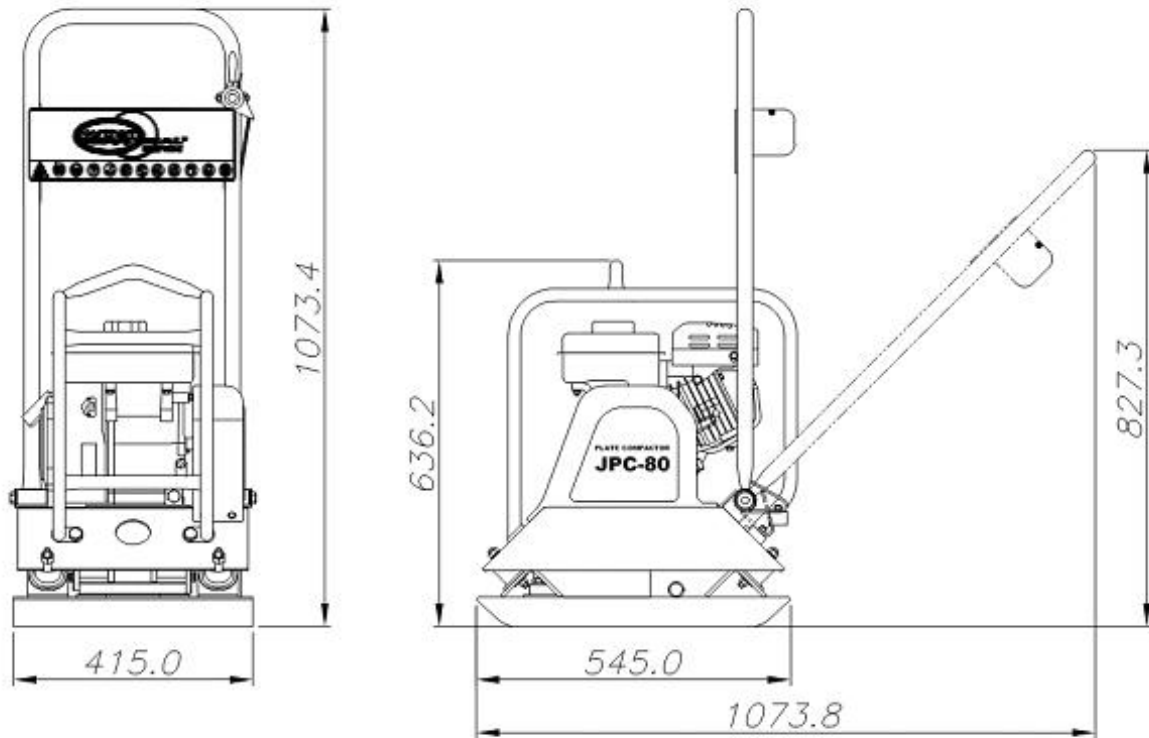

## 6. Engine



### 6.1 Recommended Fuel

- 1) Plate compactor engine requires regular, unleaded gasoline. Use only fresh, clean fuel. Fuel containing water or dirt will damage the fuel system. Consult to engine owner's manual for complete fuel specifications.

### 6.2 Before starting

- 1) Read and understand the safety and operating instruction manual of the engine.
- 2) Check Point:
  - Oil level in engine.
  - Fuel level.
  - Condition of air cleaner.
  - Tightness of external fasteners.
  - Condition of fuel lines.

### 6.3 Starting the Engine

- 1) Shift the engine On/Off switch to “on”.
  - 2) Open the fuel valve.
-  Note: If the engine is cold, move the choke lever to “close” position.
-  Note: If the engine is hot, set the choke lever at “open” position.
- 3) Move the throttle lever slightly to the left.
  - 4) Pull the starter grip gently until resistance is felt, then pull strongly.

 Note: If the engine oil level is low, the engine will not start.

 Note: If the engine does not run, check the oil level and add oil if needed.

- 5) Leave the engine run idle for 5 minutes for warm-up.
- 6) Open the throttle fully to operate plate compactor.

### 6.4 Stopping the Engine

- 1) Reduce the engine RPM to idle by moving throttle completely to the right.
- 2) Shift the engine On/Off switch to “off” position.
- 3) Close the fuel valve.

 **Please see the instruction manual of engine for further detailed information.**

## 7. Operation

 **All safety instructions must be read and observed clearly before starting to operate; lack of clarity may cause troubles of the equipment and cause personal injury.**

### 7.1 Preparation for operation

- 1) Check all the bolts, nuts and belts. If there is any looseness, tighten it.
- 2) Check the oil level. If the oil level is low, add fresh oil.
- 3) Refill the gasoline (Unleaded gasoline).

### 7.2 Operation



**Several different kinds of engines are available upon request for this plate compactor and the followings are for Honda GX160 engine made in Japan. Please make sure to read the engine instruction manual before operation.**



**Please read the engine and plate compactor user's manuals before starting or operating this plate compactor.**

- 1) Check the fuel level, engine oil and vibrating shaft oil.
- 2) Open the fuel valve and turn on the engine switch.
- 3) Set the speed control lever 1/3 to 1/2 of the way towards to high speed position in direction of arrow.
- 4) Choke the engine. Note: A warm engine may not need to be choked.
- 5) When starting the engine, place one hand on compactor's handle and other hand on the engine starter rope.
- 6) Pull the starter rope in direction of arrow.
- 7) After starting: Open the choke and allow engine to warm up at slow speed for 5 minutes.
- 8) Shift the speed control lever towards "high" position in direction of arrow after warm-up to increase the speed of engine to the required value.
- 9) To stop: Set the speed control lever at "low" position (in reverse direction of above figure) and shift the engine switch to "off" position.
- 10) Close the fuel valve.



#### **Caution**

**\*\* Whenever the high speed operation is NOT Required, slow down the engine by moving the speed control lever to low position due to saving the fuel and extending the life of the equipment and avoiding injury.**

### **7.3 Turing off the Engine**

- 1) Set the speed control lever at "low" position and leave the engine to run at low speed (idle) for 2 ~ 3 minutes before stopping.
- 2) Turn off the engine switch as turns it into "off" position.



**Never stop the engine abruptly on its full speed.**

- 3) Close the fuel valve.

- 4) Pull the starter grip slowly and return it to its original position when resistance is felt.



**Note:** The above operation is necessary to prevent outside moisture air from intruding into the combustion chamber.



**Caution**

- \*\* If the engine has been running hard, do not stop it abruptly from the full load.
- \*\* Cut down the speed (load) and allow the engine to run idle for a few more minutes.

## 8. Transportation

- 1) Transport the plate compactor by vehicle or lift crane after securely fasten with rope or chain on the motor vehicle.
- 2) Make sure to hold the transportation grip (or lifting lug) properly when lifting plate compactor. Holding the handle for transportation may cause an injury.



**Caution**

- \*\* Do not transport the plate compactor with fuel in its fuel tank by the motor vehicle.
- \*\* Never lifting the plate compactor by a person especially when to put it on and off from the transporting vehicle; it may injure on person's back.
- \*\* To avoid burns or fire hazards, let engine cool down before transporting it or indoor storage.
- \*\* Turn the fuel valve to "off" position and keep the engine level to prevent fuel from spilling.

## 9. Storage

**In case of storing the plate compactor for a long period of time (for more than 30 days):**

- 1) Remove the foreign substances such as soil, stone or dirt from plate compactor and its engine
- 2) Clean the engine cylinder cooling fins.
- 3) Clean or replace the air filter.
- 4) Change the engine oil and follow procedures described in engine manual for engine storage.
- 5) Cover it up with dry cloth completely for storage.
- 6) Store the plate compactor and its engine in a clean, dry area.

## 10. Periodic Maintenance Schedule

Please refer to the following chart for the initial maintenance of plate compactor and its engine. Also please see the enclosed engine manufacturer's instruction manual for additional information about engine maintenance.



The following chart is based on the normal operation schedule.

Maintenance Interval	Maintenance Point
Daily before operating	Check the fuel level. Check the engine oil level. Inspect the fuel lines. Inspect the air filter and replace it if needed. Check and tighten the external hardware.
After the first 20 operating hours	Check and adjust the drive belt. Change the engine oil.
After the first 50 operating hours or every week	Check and adjust the drive belt. Clean the air cleaner element. Change the engine oil. Check and clean the spark plug.
After the first 100 operating hours or every month	Clean the fuel strainer.
After the first 300 operating hours or every year	Check and adjust the valve clearance. Clean the cylinder head. Change the lubrication oil ( <b>SHELL OMALA #100 OR SAE 10W/30, 150CC</b> )

## 11. Troubleshooting

Please check the list below before addressing the problems to servicing personnel including local dealer. If the problem continues after the following troubleshooting, please call your local dealer for future assistance.

Failure	Possible Cause	Remedial Measure
Poor performance (Plate compactor does not develop its full speed.)	<ul style="list-style-type: none"> <li>- The engine throttle does not open completely.</li> <li>- The throttle does not adjusted correctly.</li> <li>- The ground is too wet for compacting.</li> <li>- Drive belt is loosened or worn out, slipping on pulleys.</li> <li>- Vibrating shaft bearings (#19) is binding.</li> <li>- Air filter is clogged with dust which reduces engine performance.</li> <li>- The engine speed is too low.</li> </ul>	<ul style="list-style-type: none"> <li>- Open the engine throttle completely.</li> <li>- Adjust the throttle controller correctly.</li> <li>- Dry the soil before compacting.</li> <li>- Adjust/replace the belt. Or check whether the engine mounting bolts are tightened.</li> <li>- Check the condition &amp; the level of the oil in vibrator housing, and add/change the oil.</li> <li>- Clean/replace the air filter cartridge.</li> <li>- Check the engine speed with tachometer and adjust/repair the engine to run at correct speed.</li> </ul> <p>Note: Refer to the engine manual.</p>
Engine is running but no vibration	<ul style="list-style-type: none"> <li>- The engine throttle is not opened.</li> <li>- Clutch is damaged.</li> <li>- Engine speed is too low.</li> </ul>	<ul style="list-style-type: none"> <li>- The drive belt is loosened or broken. Adjust/replace it.</li> <li>- Inspect/replace the clutch.</li> <li>- Too much oil in the exciter. Adjust the oil level in exciter.</li> </ul>
Plate jumps or compacts unevenly.	<ul style="list-style-type: none"> <li>- The ground surface is too hard.</li> <li>- Rubber isolator is loosened or damaged.</li> </ul>	<ul style="list-style-type: none"> <li>- Adjust/replace the rubber isolator.</li> </ul>

## 12. Components and Part list

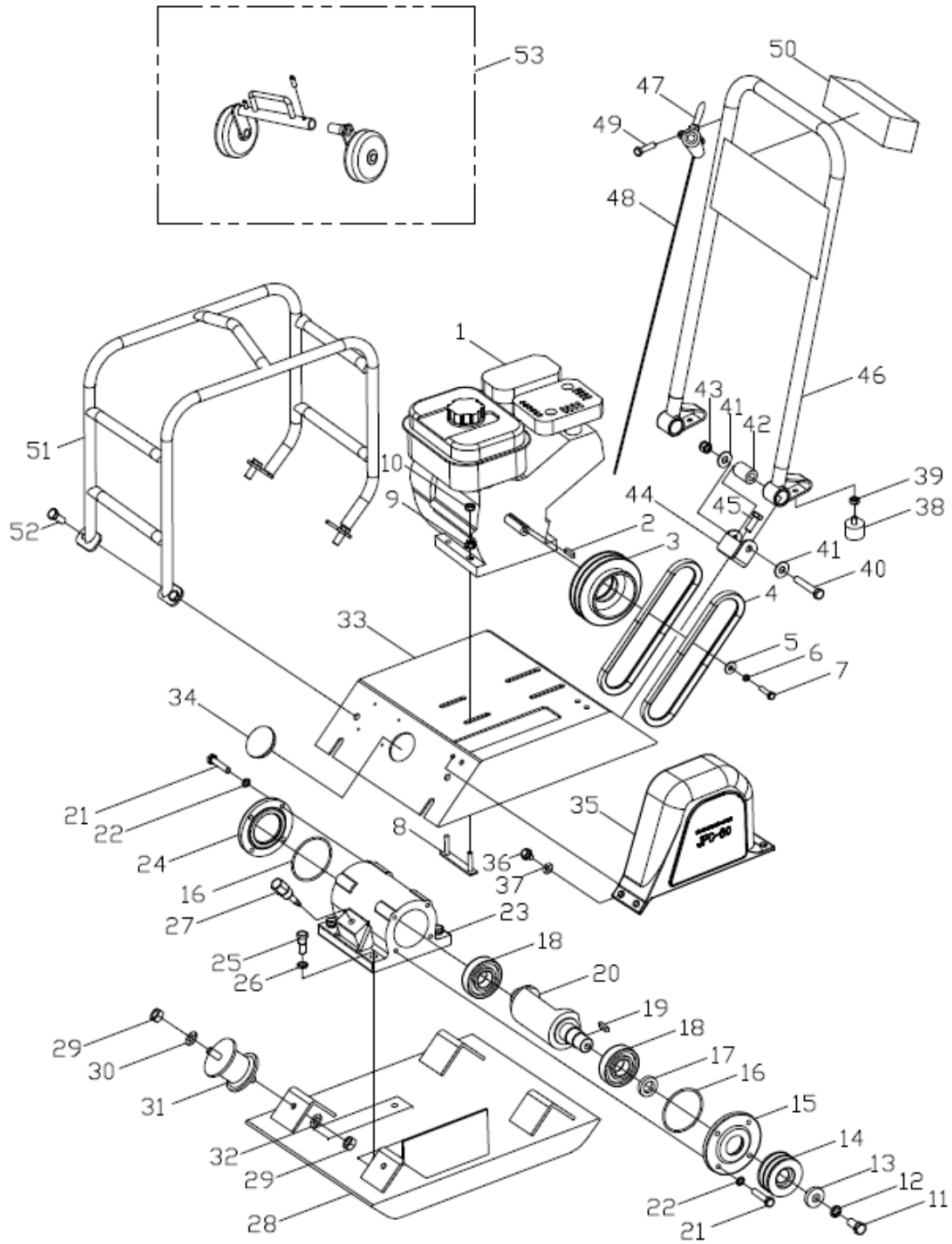

REF	Description	Q'TY	Dimension
1	Engine	1	Honda GX160/ Robin EX17
2	Key	1	5 x 5 x 20m/m(square)
3	Centrifugal Clutch	1	18, 19, 20m/m
4	V-Belt	2	A30
5	Washer	1	8m/m
6	Spring Washer	1	8m/m
7	Bolt	1	8 x 40m/m
8	Engine Fitting Bolt Set	2	8 x 50m/m (specialty steel)
9	Flange Nut	4	8m/m
10	Nut	8	8m/m
11	Pulley Fitting Bolt	1	12 x 20m/m
12	Spring Washer	1	12m/m
13	Washer	1	12m/m
14	Pulley	1	*
15	Housing Cover "A"	1	*
16	O-Ring	2	G80
17	Oil Seal	1	32 x 48NOK
18	Bearing	2	6307OP
19	Key	1	*
20	Vibrating Shaft	1	*
21	Housing Cover Fitting Bolt	8	8 x 25m/m (specialty steel)
22	Spring Washer	8	8m/m
23	Vibratory Housing	1	*
24	Housing Cover "B"	1	*
25	Bolt	4	12 x 40m/m (specialty steel)
26	Spring Washer	4	12m/m
27	Oil Cap (Gauge)	1	*
28	Vibrating Plate	1	545 x 420m/m
29	Lock Nut	8	10m/m
30	Washer	4	10m/m
31	Rubber Isolator "A"	4	10m/m
32	Spring Washer	4	10m/m



33	Engine Base Ass'y	1	520 x 450 x 110m/m
34	Rubber Cap	1	*
35	Belt Cover	1	*
36	Flange Bolt	4	8 x 20m/m
37	Washer	4	8m/m
38	Catching Rubber	2	*
39	Nut	2	*
40	Bolt	2	12 x 70m/m
41	Washer	4	12m/m
42	Rubber Isolator "B"	2	*
43	Lock Nut	2	12m/m
44	Handle Bracket	1	780 x 375m/m
45	Bolt	1	*
46	Handle		
47	Speed Control Bar		
48	Speed Control Bar Lever Cable	1	*
49	Speed Control Bar Fitting bolt	1	*
50	Tool Bag		
51	Frame	1	*
52	Bolt	4	*
53	Transfer Wheel Set	1	OPTION

### 13. Warranty Policy

- 1) Warranty policies for the Products are shown on the following table.
- 2) **NORTHERN industrial** shall supply all necessary parts for the replacement or repair at free of charge, if and only if, when the defects are proved to be derived from mill defect by 3rd party inspection or joint inspection of the two (2) parties.
- 3) The products under specific private brand name according to the Buyer's requirements are treated in the same manner.
- 4) However, any defect caused by normal wear and tear, misuse, improper maintenance, alterations and repairs with non-confirming parts or by unauthorized person and negligence to read manual before the operation shall not be subject to the Warranty even during the period of warranty.

Product	Warranty period	Remarks
Concrete vibrator Handy vibrator Portable engine vibrator Submersible pump High cycle eccentric vibrator	6 (six) months under normal operation from the date of shipment from Korea, or 150 (one hundred fifty) days from your date of sale (or purchase) to the 3rd party, which ever comes first.	In case of warranty claim, please send Claim report with following information. Date of arrival & sale Occurrence date Description of product
Plate compactor(reversible) Power trowel Concrete cutter Electric motor Vibration motor Turn table (Chassis)	12 (twelve) months under normal operation from the date of shipment from Korea, or 330 (three hundred & thirty) days from the date of sale (or purchase) to the 3rd party, which ever comes first.	Quantity of defect Pictures for showing defects clearly Suspected reason of the defect Recommendation Others
Engine	Refer to engine manual	