

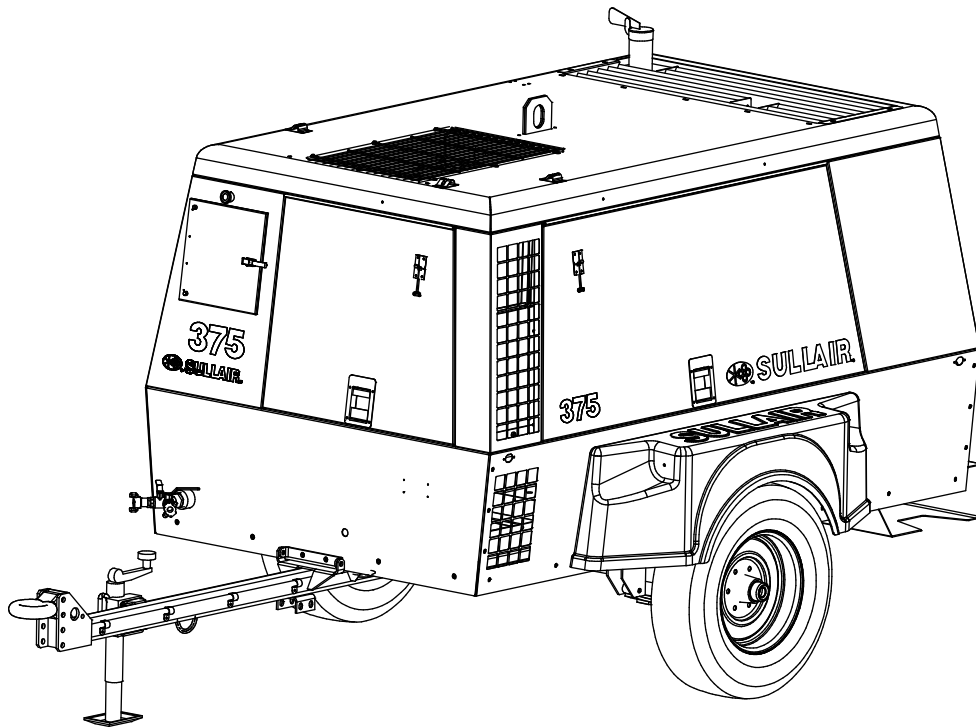

PORTABLE AIR COMPRESSOR 300HH, 375, 375H AND 425

Caterpillar Standard and Aftercooled and Filtered



**PART NUMBER:
02250169-726 R01**

**KEEP FOR
FUTURE
REFERENCE**

©SULLAIR CORPORATION

The information in this document
is correct at the time of printing for
portable compressor serial number
200705010000
and all subsequent serial numbers.

OPERATOR'S MANUAL AND PARTS LIST



AIR CARE SEMINAR TRAINING

Sullair Air Care Seminars are courses that provide hands-on instruction in the proper operation, maintenance and service of Sullair equipment. Individual seminars on Portable compressors are presented at regular intervals throughout the year at a dedicated training facility at Sullair's corporate headquarters in Michigan City, Indiana.

Instruction includes discussion of the function and installation of Sullair service parts, troubleshooting of the most common problems, and actual equipment operation. The seminars are recommended for Rental House, Contractor Maintenance and Service Personnel.

For detailed course outlines, schedule and cost information contact:

Sullair Customer Care Training Department

 : 1-888-SULLAIR or
219-879-5451 (ext. 5363)
www.sullair.com

- Or Write -

Sullair Corporation
3700 E. Michigan Blvd.
Michigan City, IN 46360
Attn: Service Training Department



TABLE OF CONTENTS

Contents

1 - SAFETY	1
General	1
Towing (I)	1
Preparing To Tow	1
Towing	3
Parking Or Locating Compressor	3
Pressure Release	4
Fire And Explosion	5
Moving Parts	6
Hot Surfaces, Sharp Edges And Sharp Corners	6
Toxic And Irritating Substances	6
Electrical Shock	7
Lifting	7
Entrapment	8
Jump Starting	8
California Proposition 65	9
Implementation of Lockout/Tagout	9
explosive atmosphere	10
2 - DESCRIPTION	11
Introduction	11
Description Of Components	11
Sullair Compressor Unit, Functional Description	13
Compressor Cooling And Lubrication System, Functional Description	13
Compressor Discharge System, Functional Description	14
Capacity ContRol SysTem, Functional Description	14
Start – 0 To 40 psig (0 To 2.8 Bar) Cold Start	14
Normal Operation – 80 to 100 psig (5.6 to 6.9 bar) or 80 to 150 psig (5.6 to 10.3 bar) for H machines or 80 to 200 psig (5.6 to 13.8 bar) for HH machines	22
Modulation – 100 to 110 psig (6.9 to 7.5 bar) or 150 to 165 psig (10.3 to 11.4 bar) for H machines or 200 to 220 psig (13.8 to 15.2 bar) for HH machines	22
Shutdown	22
Air Inlet System, Functional Description	22
Instrument Panel Group, Functional Description	22

Wiring Diagram	37
Electrical System, Functional Description	38
Compressor Shutdown & Warning System, Functional Description	38
Aftercooled And Filtered Air System, Functional Description	39
Listing of Diagnostic Codes	40
Trouble Codes	40
Operation of the Indicator Lamps	43
Flash Codes	44
3 - SPECIFICATIONS	45
Specifications – 300HH and 375 Caterpillar	45
Specifications – 375H and 425 Caterpillar	46
Lubrication Guide – Compressor	48
Application Guide	48
Lubrication Guide – Engine	48
4 - GENERAL	49
General	49
Purpose Of Controls	49
Control or Indicator Purpose	49
Initial Startup/Shutdown Procedure	50
Startup	50
Shutdown	50
Restart Procedure	50
5 - MAINTENANCE	51
General	51
Daily Maintenance	51
Maintenance After Initial 50 Hours Of Operation	52
Maintenance Every 50 Hours	52
Maintenance Every 100 Hours	52
Maintenance Every 250 Hours	52
Maintenance Every 1500 Hours	52
Part Replacement And Adjustment Procedures	53
Compressor Fluid Change Procedure	53
Compressor Fluid Filter Element Replacement	53
Air Filter Maintenance	53
Air Filter Replacement	53
Element Inspection	54
Separator Element Replacement	54
Procedure For Setting Speed And Pressure Controls On Portable Compressors Equipped With Poppet Valves	54
Bearing Lubrication	56
First and Second Stage Discharge Air Filter Maintenance – Aftercooled & Filtered Models	57
Trouble Shooting	58
6 - NOISE CONTROL	63
Noise Emissions Warranty	63
Tampering with the Noise Control System is Prohibited	63
Noise Emission Maintenance and Maintenance Record Log	64
Noise Emissions Maintenance and Maintenance Record Log	64
Procedure For Ordering Parts	67
7 - ILLUSTRATIONS AND PARTS LIST	67
Recommended Spare Parts List	69
Engine, Compressor And Parts	70
Radiator & Compressor Fluid Cooling System	74
Air Inlet System & Exhaust System	78

Control Parts & Discharge Parts - 375 and 425..... 80
Control Parts & Discharge Parts - 300HH and 375H 84
Regulator/Blowdown Valve - 375 And 425 88
Regulator/Blowdown Valve - 300HH and 375H 90
Control Parts Orifice - 300HH and 375H..... 92
Service Valves..... 94
Optional AfterCooler/Filter And Parts 96
Electrical Parts 100
Instrument Panel & Parts 104
Fuel Tank & Connections 108
Frame, Axle & Parts And Axle Assembly..... 110
Axle Assembly..... 114
Canopy, Acoustical Panels & Parts 116
Decals 118
Decal Locations 130

THIS PAGE INTENTIONALLY LEFT BLANK

Section 1

SAFETY

NOTE

OPERATOR IS REQUIRED TO READ ENTIRE INSTRUCTION MANUAL.

Each day, walk around the air compressor and inspect for leaks, loose or missing parts, damaged parts or parts out of adjustment. Perform all recommended daily maintenance.

Inspect for torn, frayed, blistered or otherwise deteriorated and degraded hoses. Replace as required.

⚠ CAUTION
<p>Estimated hose life based on a 5-day 8-hour work week is 3 years. These conditions exist on an 8-hour shift only. Any other operation of the equipment other than 8-hour shifts would shorten the hose life based on hours of operation.</p>

1.1 GENERAL

Sullair Corporation designs and manufactures all of its products so they can be operated safely. However, the responsibility for safe operation rests with those who use and maintain these products. The following safety precautions are offered as a guide which, if conscientiously followed, will minimize the possibility of accidents throughout the useful life of this equipment.

Read the CIMA Safety Manual prior to compressor operation and towing, if applicable in your area.

The air compressor should be operated only by those who have been trained and delegated to do so, and who have read and understood this Operator's Manual. Failure to follow the instructions, procedures and safety precautions in this manual can result in accidents and injuries.

NEVER start the air compressor unless it is safe to do so. **DO NOT** attempt to operate the air compressor with a known unsafe condition. Tag the air compressor and render it inoperative by disconnecting the battery so others who may not know of the unsafe condition will not attempt to operate it until the condition is corrected.

Use and operate the air compressor only in full compliance with all pertinent OSHA requirements and/or all pertinent Federal, State and Local codes or requirements.

DO NOT modify the compressor except with written factory approval.

1.2 TOWING

NOTE
<p>While not towed in the usual sense of the word, many of these instructions are directly applicable to skid-mounted portable air compressors as well.</p>

Preparing To Tow

⚠ WARNING
<p>DO NOT tow the compressor should its weight exceed the rated limit of the tow vehicle, as the vehicle may not brake safely with excess weight. See rated limit in tow vehicle Operator's Manual, and review its instructions and other requirements for safe towing.</p>

SECTION 1

- A. Prior to hitching the air compressor to the tow vehicle, inspect all attachment parts and equipment, checking for (i) signs of excessive wear or corrosion, (ii) parts that are cracked, bent, dented or otherwise deformed or degraded, and (iii) loose nuts, bolts or other fasteners. Should any such condition be present, **DO NOT TOW** until the problem is corrected.
- B. Back the tow vehicle to the compressor and position it in preparation for coupling the compressor.
- C. If the compressor is provided with a drawbar latched in the vertical upright position, carefully unlatch drawbar and lower it to engage the coupling device. If not, raise drawbar to engage coupling device or otherwise couple the compressor to the towing vehicle.

WARNING

This equipment may be tongue heavy. **DO NOT** attempt to raise or lower the drawbar by hand if the weight is more than you can safely handle.

Use the screw jack provided or a chain fall if you cannot lift or lower it without avoiding injury to yourself or others. Keep hands and fingers clear of the coupling device and all other pinch points. Keep feet clear of drawbar to avoid injury in case it should slip from your hands.

- D. Make sure the coupling device is fully engaged, closed and locked.
- E. If chains are provided, pass each chain through its point of attachment on the towing vehicle; then hook each chain to itself by passing the grab hook over (not through) a link. Cross chains under front of drawbar before passing them through points of attachment on towing vehicle to support front of drawbar in case it should accidentally become uncoupled.
- F. Make sure that the coupling device and adjacent structures on the towing vehicle (and also, if utilized, chain adjustment, brake and/or electrical interconnections) **DO NOT** interfere with or restrict motion of any part of the compressor, including its coupling device, with respect to the towing vehicle when maneuvering over any anticipated terrain.

- G. If provided, make sure chain length, brake and electrical interconnections provide sufficient slack to prevent strain when cornering and maneuvering, yet are supported so they cannot drag or rub on road, terrain or towing vehicle surfaces which might cause wear that could render them inoperative.

WARNING

This equipment may be tongue heavy. **DO NOT** attempt to raise or lower the drawbar by hand if the weight is more than you can safely handle.

CAUTION

Retract the front screw jack only after attaching the compressor to the tow vehicle. Raise the screw jack to its full up position and pull the pin connecting the jack to the drawbar. Rotate the screw jack to its stowed position, parallel to the drawbar, and reinsert the pin. Make sure the jack is secured in place prior to towing.

If a caster wheel is provided on the screw jack it is part of the screw jack and can not be removed. Follow the same procedure for stowing away the wheeled jack as you would for the standard screw jack. Pull the pin connecting the jack to the drawbar and raise the screw jack to its full up position. Rotate the screw jack to its stowed position, parallel to the drawbar, and reinsert the pin. Make sure the jack is secured in place prior to towing.

- H. On two-wheeled models, fully retract front screw jack and any rear stabilizer legs. If a caster wheel is provided on the screw jack it is part of the screw jack, and can not be removed. Follow the same procedure for stowing away the wheeled jack as you would for the standard screw jack. Pull the pin connecting the jack to the drawbar and raise the screw jack to its full upright position. Rotate the screw jack to its stowed position, parallel to the drawbar, and reinsert the pin. Make sure the jack is secured in place prior to towing.
- I. Make sure tires are in good condition and are the size (load range) specified and are inflated to the specified pressures. **DO NOT** change the tire size or type. Also, make sure wheel bolts, lugs or nuts are tightened to the specified torques.

- J. If provided, make sure all dual stop, tail directional and clearance lights are operating properly and that their lenses are clean and functional. Also, make sure all reflectors and reflecting surfaces, including the slow moving vehicle emblem on compressors provided with same, are clean and functional.
- K. Make sure all service air hoses (not air brake hoses) are disconnected or are fully stowed and secured on hose reels, if provided.
- L. Make sure all access doors and tool box covers are closed and latched. If the compressor is large enough to hold a man, make sure all personnel are out before closing and latching access doors.
- M. Make sure parking brakes in towing vehicle are set, or that its wheels are chocked or blocked, or that it is otherwise restrained from moving. Then, release the compressor parking brakes, if provided.
- N. Make sure the compressor wheels are not chocked or blocked, and that all tie-downs, if any, are free.
- O. Test running brake operation, including breakaway switch operation if provided, before attempting to tow the compressor at its rated speed or less when conditions prevail.
- P. **DO NOT** carry loose or inappropriate tools, equipment or supplies on or in the compressor.
- Q. **DO NOT** load this equipment with accessories or tools such that it is unbalanced from side to side or front to back. Such unbalance will reduce the towability of this equipment and may increase the possibility of tipping, rolling over, jackknifing, etc. Loss of control of the towing vehicle may result.

Towing

- A. Observe all Federal, State, and Local laws while towing this equipment (including those specifying minimum speed).
- B. **DO NOT** exceed the towing speeds listed below under ideal conditions. Reduce your speed according to posted speed limits, weather, traffic, road or terrain conditions:
 1. Two axle four-wheel or three axle six-wheel steerable models: 15 MPH (24 km/h).
 2. All other models: 55 MPH (88 km/h).
- C. Remember that the portable air compressor may approach or exceed the weight of the towing vehicle. Maintain increased stopping distances accordingly. **DO NOT** make sudden lane changes, U-turns or other maneuvers. Such maneuvers can cause the compressor to tip, roll over, jackknife or slide and cause loss of control of the towing vehicle. Tipping, rolling over, etc. can occur suddenly without warning. U-turns especially should be made slowly and carefully.
- D. Avoid grades in excess of 15° (27%).
- E. Avoid potholes, rocks and other obstructions, and soft shoulders or unstable terrain.
- F. Maneuver in a manner that will not exceed the freedom of motion of the compressor's drawbar and/or coupling device, in or on the towing vehicle's coupling device and/or adjacent structure whether towing forward or backing up, regardless of the terrain being traversed.
- G. **DO NOT** permit personnel to ride in or on the compressor.
- H. Make sure the area behind, in front of, and under the compressor is clear of all personnel and obstructions prior to towing in any direction.
- I. **DO NOT** permit personnel to stand or ride on the drawbar, or to stand or walk between the compressor and the towing vehicle.

Parking Or Locating Compressor

- A. Park or locate compressor on a level surface, if possible. If not, park or locate compressor across grade so the compressor does not tend to roll downhill. **DO NOT** park or locate compressor on grades exceeding 15° (27%).
- B. Make sure compressor is parked or located on a firm surface that can support its weight.
- C. Park or locate compressor so the wind, if any, tends to carry the exhaust fumes and radiator heat away from the compressor air inlet openings, and also where the compressor will not be exposed to excessive dust from the work site.
- D. On steerable models, park compressor with front wheels in straight-ahead position.
- E. Set parking brakes and disconnect breakaway switch cable and all other interconnecting electrical and/or brake connections, if provided.
- F. Block or chock both sides of all wheels.
- G. If provided, unhook chains and remove them from the points of chain attachment on the towing vehicle, then hook chains to bail on drawbar or wrap chains around the drawbar and hook them to themselves to keep chains off the ground which might accelerate rusting.

- H. Lower front screw jack and/or any front and rear stabilizer legs. Make sure the surface they contact has sufficient load bearing capability to support the weight of the compressor.

⚠ WARNING
This equipment may be tongue heavy. DO NOT attempt to raise or lower the drawbar by hand if the weight is more than you can safely handle.

⚠ CAUTION
<p>Retract the front screw jack only after attaching the compressor to the tow vehicle. Raise the screw jack to its full up position and pull the pin connecting the jack to the drawbar. Rotate the screw jack to its stowed position, parallel to the drawbar, and reinsert the pin. Make sure the jack is secured in place prior to towing.</p> <p>On two-wheeled models, fully retract front screw jack and any rear stabilizer legs. If a caster wheel is provided on the screw jack it is part of the screw jack and can not be removed. Follow the same procedure for stowing away the wheeled jack as you would for the standard screw jack. Pull the pin connecting the jack to the drawbar and raise the screw jack to its full up position. Rotate the screw jack to its stowed position, parallel to the drawbar, and reinsert the pin. Make sure the jack is secured in place prior to towing.</p>

- I. If a caster wheel is provided on the screw jack, it is part of the screw jack and cannot be removed. Follow the same procedure for stowing away the wheeled jack as you would for the standard screw jack. Raise the screw jack to its full upright position and pull the pin connecting the jack to the drawbar. Rotate the screw jack to its stowed position, parallel to the drawbar and reinsert the pin. Make sure the jack is secured in place prior to towing.
- J. Disconnect coupling device, keeping hands and fingers clear of all pinch points. If the compressor is provided with a drawbar, **DO NOT** attempt to lift the drawbar or if hinged, to raise it to the upright position by hand, if the weight is more than you can safely handle. Use a screwjack or chain fall if you cannot lift or raise the drawbar without avoiding injury to yourself or others.

- K. When possible, stow hinged drawbar in the vertical upright position. Make certain it is securely latched in the vertical upright position. Keep feet clear of drawbar at all times to avoid crushing accidents in case it should slip from your hands or otherwise fall to the ground.
- L. Move the towing vehicle well clear of the parked compressor and erect hazard indicators, barricades and/or flares (if at night) if compressor is parked on or adjacent to public roads. Park so as not to interfere with traffic.

NOTE
While not towed in the usual sense of the word, many of these instructions are directly applicable to skid-mounted portable air compressors as well.

1.3 PRESSURE RELEASE

- A. Open the pressure relief valve at least weekly to make sure it is not blocked, closed, obstructed or otherwise disabled.
- B. Install an appropriate flow-limiting valve between the compressor service air outlet and the shutoff (throttle) valve, when an air hose exceeding 1/2" (13 mm) inside diameter is to be connected to the shutoff (throttle) valve, to reduce pressure in case of hose failure, per OSHA Standard 29 CFR 1926.302 (b) (7) or any applicable Federal, State and Local codes, standards and regulations.
- C. When the hose is to be used to supply a manifold, install an additional appropriate flow-limiting valve between the manifold and each air hose exceeding 1/2" (13 mm) inside diameter that is to be connected to the manifold to reduce pressure in case of hose failure.
- D. Provide an appropriate flow-limiting valve for each additional 75 feet (23 m) of hose in runs of air hose exceeding 1/2" (13 mm) inside diameter to reduce pressure in case of hose failure.
- E. Flow-limiting valves are listed by pipe size and rated CFM. Select appropriate valve accordingly.
- F. **DO NOT** use tools that are rated below the maximum rating of this compressor. Select tools, air hoses, pipes, valves, filters and other fittings accordingly. **DO NOT** exceed manufacturer's rated safe operating pressures for these items.
- G. Secure all hose connections by wire, chain or other suitable retaining device to prevent tools or hose ends from being accidentally disconnected and expelled.
- H. Open fluid filler cap only when compressor is not running and is not pressurized. Shut down the compressor and bleed the sump (receiver) to zero internal pressure before removing the cap.

- I. Vent all internal pressure prior to opening any line, fitting, hose, valve, drain plug, connection or other component, such as filters and line oilers, and before attempting to refill optional air line anti-icer systems with antifreeze compound.
- J. Keep personnel out of line with and away from the discharge opening of hoses, tools or other points of compressed air discharge.
- K. **DO NOT** use air at pressures higher than 30 psig (2.1 bar) for cleaning purposes, and then only with effective chip guarding and personal protective equipment per OSHA Standard 29 CFR 1910.242 (b) or any applicable Federal, State and Local codes, standards and regulations.
- L. **DO NOT** engage in horseplay with air hoses as death or serious injury may result.
- M. This equipment is supplied with an ASME designed pressure vessel protected by an ASME rated relief valve. Lift the handle once a week to make sure the valve is functional. **DO NOT** lift the handle while machine is under pressure.
- N. If the machine is installed in an enclosed area it is necessary to vent the relief valve to the outside of the structure or to an area of non-exposure.
- O. **DO NOT** remove radiator filler cap until the coolant temperature is below its boiling point. Then loosen cap slowly to its stop to relieve any excess pressure and make sure coolant is not boiling before removing cap completely. Remove radiator filler cap only when cool enough to touch with a bare hand.
- P. The ethyl ether in the replaceable cylinders used in diesel ether starting aid systems (optional) is under pressure. **DO NOT** puncture or incinerate those cylinders. **DO NOT** attempt to remove the center valve core or side pressure relief valve from these cylinders regardless of whether they are full or empty.
- Q. If a manual blowdown valve is provided on the receiver, open the valve to ensure all internal pressure has been vented prior to servicing any pressurized component of the compressor air/fluid system.
- D. **DO NOT** permit liquids, including air line anti-icer system antifreeze compound or fluid film, to accumulate on bottom covers or on, under or around acoustical material, or on any external or internal surfaces of the air compressor. Wipe down using an aqueous industrial cleaner or steam clean as required. If necessary, remove acoustical material, clean all surfaces and then replace acoustical material. Any acoustical material with a protective covering that has been torn or punctured should be replaced immediately to prevent accumulation of liquids or fluid film within the material. **DO NOT** use flammable solvents for cleaning purposes.
- E. Disconnect the grounded (negative) battery connection prior to attempting any repairs or cleaning inside the enclosure. Tag the battery connections so others will not unexpectedly reconnect it.
- F. Keep electrical wiring, including the battery terminals and other terminals, in good condition. Replace any wiring that has cracked, cut abraded or otherwise degraded insulation or terminals that are worn, discolored or corroded. Keep all terminals clean and tight.
- G. Turn off battery charger before making or breaking connections to the battery.
- H. Keep grounded conductive objects such as tools away from exposed live electrical parts such as terminals to avoid arcing which might serve as a source of ignition.
- I. Replace damaged fuel tanks or lines immediately rather than attempt to weld or otherwise repair them. **DO NOT** store or attempt to operate the compressor with any known leaks in the fuel system. Tag the compressor and render it inoperative until repair can be made.
- J. Remove any acoustical material or other material that may be damaged by heat or that may support combustion prior to attempting weld repairs. Remove diesel engine ether starting aid cylinders and air line anti-icer system components containing antifreeze compound, prior to attempting weld repairs in any place other than the fuel system. **DO NOT** weld on or near the fuel system.

1.4 FIRE AND EXPLOSION

- A. Refuel at a service station or from a fuel tank designed for its intended purpose. If this is not possible, ground the compressor to the dispenser prior to refueling.
- B. Clean up spills of fuel, fluid, battery electrolyte or coolant immediately if such spills occur.
- C. Shut off air compressor and allow it to cool. Then keep sparks, flames and other sources of ignition away and **DO NOT** permit smoking in the vicinity when adding fuel, or when checking or adding electrolyte to batteries, or when checking or adding fluid, or when checking diesel engine ether starting aid systems or replacing cylinders, or when refilling air line anti-icer systems antifreeze compound.
- K. Keep a suitable, fully charged class BC or ABC fire extinguisher or extinguishers nearby when servicing and operating the compressor.
- L. Keep oily rags, trash, leaves, litter or other combustibles out of and away from the compressor.
- M. Open all access doors and allow the enclosure to ventilate thoroughly prior to attempting to start the engine.
- N. **DO NOT** operate compressor under low overhanging leaves or permit such leaves to contact hot exhaust system surfaces when operating the compressor in forested areas.

SECTION 1

- O. Ethyl ether used in diesel engine ether starting aid systems is extremely flammable. Change cylinders, or maintain or troubleshoot these systems only in well-ventilated areas away from heat, open flame or sparks. **DO NOT** install, store or otherwise expose ether cylinders to temperatures above 160 °F (71 °C). Remove ether cylinder from the compressor when operating in ambient temperatures above 60 °F (16 °C).
- P. **DO NOT** attempt to use ether as a starting aid in gasoline engines or diesel engines with glow plugs as serious personnel injury or property damage may result.
- Q. **DO NOT** spray ether into compressor air filter or into an air filter that serves both the engine and the compressor as serious damage to the compressor or personal injury may result.
- R. Antifreeze compound used in air line anti-icer systems contains methanol which is flammable. Use systems and refill with compound only in well-ventilated areas away from heat, open flames or sparks. **DO NOT** expose any part of these systems or the antifreeze compound to temperatures above 150 °F (66 °C). Vapors from the antifreeze compound are heavier than air. **DO NOT** store compound or discharge treated air in confined or unventilated areas. **DO NOT** store containers of antifreeze compound in direct sunlight.
- S. Store flammable fluids and materials away from your work area. Know where fire extinguishers are and how to use them, and for what type of fire they are intended. Check readiness of fire suppression systems and detectors if so equipped.

1.5 MOVING PARTS

- A. Keep hands, arms and other parts of the body and also clothing away from belts, pulleys and other moving parts.
- B. **DO NOT** attempt to operate the compressor with the fan or other guards removed.
- C. Wear snug-fitting clothing and confine long hair when working around this compressor, especially when exposed to hot or moving parts inside the enclosure.
- D. Keep access doors closed except when making repairs or adjustments, performing service or when starting or stopping the compressor.
- E. Make sure all personnel are out of and clear of the compressor prior to attempting to start or operate it.
- F. Shut off engine before adding fuel, fluid, coolant lubricants, air line antifreeze compound or battery electrolyte, or before replacing ether starting aid cylinders.
- G. Disconnect the grounded negative battery connection to prevent accidental engine operation prior to attempting repairs or adjustments. Tag the battery connection so others will not unexpectedly reconnect it.
- H. When adjusting the controls, it may require operation of the equipment during adjustment. **DO NOT** come in contact with any moving parts while adjusting the control regulator and setting the engine RPM. Make all other adjustments with the engine shut off. When necessary, make adjustment, other than setting control regulator and engine RPM, with the engine shut off. If necessary, start the engine and check adjustment. If adjustment is incorrect, shut engine off, readjust, then restart the engine to recheck adjustment.
- I. Keep hands, feet, floors, controls and walking surfaces clean and free of fluid, water, antifreeze or other liquids to minimize possibility of slips and falls.

1.6 HOT SURFACES, SHARP EDGES AND SHARP CORNERS

- A. Avoid bodily contact with hot fluid, hot coolant, hot surfaces and sharp edges and corners.
- B. Keep all parts of the body away from all points of air discharge and away from hot exhaust gases.
- C. Wear personal protective equipment including gloves and head covering when working in, on or around the compressor.
- D. Keep a first aid kit handy. Seek medical assistance promptly in case of injury. **DO NOT** ignore small cuts and burns as they may lead to infection.

1.7 TOXIC AND IRRITATING SUBSTANCES

- A. **DO NOT** use air from this compressor for respiration (breathing) except in full compliance with OSHA Standards 29 CFR 1920 and any other Federal, State or Local codes or regulations.



INHALATION HAZARD! Death or serious injury can result from inhaling compressed air without using proper safety equipment. See OSHA standards and/or any applicable Federal, State, and Local codes, standards and regulations on safety equipment.

- B. **DO NOT** use air line anti-icer systems in air lines supplying respirators or other breathing air utilization equipment and **DO NOT** discharge air from these systems into unventilated or other confined areas.

- C. Operate the compressor only in open or well-ventilated areas.
 - D. If the compressor is operated indoors, discharge engine exhaust fumes outdoors.
 - E. Locate the compressor so that exhaust fumes are not apt to be carried towards personnel, air intakes servicing personnel areas or towards the air intake of any portable or stationary compressor.
 - F. Fuels, fluids, coolants, lubricants and battery electrolyte used in the compressor are typical of the industry. Care should be taken to avoid accidental ingestions and/or skin contact. In the event of ingestion, seek medical treatment promptly. **DO NOT** induce vomiting if fuel is ingested. Wash with soap and water in the event of skin contact.
 - G. Wear an acid-resistant apron and a face shield or goggles when servicing the battery. If electrolyte is spilled on skin or clothing, immediately flush with large quantities of water.
 - H. Ethyl ether used in diesel engine ether starting aid systems is toxic, harmful or fatal if swallowed. Avoid contact with the skin or eyes and avoid breathing the fumes. If swallowed, **DO NOT** induce vomiting, but call a physician immediately.
 - I. Wear goggles or a full face shield when testing ether starting aid systems or when adding antifreeze compound to air line anti-icer systems. Keep openings of valve or atomizer tube of ether starting aid system pointed away from yourself and other personnel.
 - J. If ethyl ether or air line anti-icer system antifreeze compound enters the eyes or if fumes irritate the eyes, they should be washed with large quantities of clean water for 15 minutes. A physician, preferably any eye specialist, should be contacted immediately.
 - K. **DO NOT** store ether cylinders or air line anti-icer system antifreeze compound in operator's cabs or in other similar confined areas.
 - L. The antifreeze compound used in air line anti-icer systems contains methanol and is toxic, harmful or fatal if swallowed. Avoid contact with the skin or eyes and avoid breathing the fumes. If swallowed, induce vomiting by administering a tablespoon of salt in each glass of clean warm water until vomit is clear, then administer two tablespoons of baking soda in a glass of clean water. Have patient lay down and cover eyes to exclude light. Call a physician immediately.
- B. Keep all parts of the body and any hand-held tools or other conductive objects away from exposed live parts of electrical system. Maintain dry footing, stand on insulating surfaces and **DO NOT** contact any other portion of the compressor when making adjustments or repairs to exposed live parts of the electrical system.
 - C. Attempt repairs only in clean, dry and well-lighted and ventilated areas.
 - D. Stay clear of the compressor during electrical storms! It can attract lightning.

1.9 LIFTING

- A. If the compressor is provided with a lifting bail, then lift by the bail provided. If no bail is provided, then lift by sling. Compressors to be air lifted by helicopter must not be supported by the lifting bail, but by slings instead. In any event, lift only in full compliance with OSHA Standards 29 CFR 1910 subpart N or any other Local, State, Military and Federal regulations that may apply.
- B. Inspect lifting bail and points of attachment for cracked welds and for cracked, bent, corroded or otherwise degraded members and for loose bolts or nuts prior to lifting.
- C. Make sure entire lifting, rigging and supporting structure has been inspected, is in good condition and has a rated capacity of at least the net weight of the compressor plus an additional 10% allowance for weight of snow, ice, mud or stored tools and equipment. If you are unsure of the weight, then weigh compressor before lifting.
- D. Make sure lifting hook has a functional safety latch or equivalent, and is fully engaged and latched on the bail.
- E. Use guide ropes or equivalent to prevent twisting or swinging of the compressor once it has been lifted clear of the ground.
- F. **DO NOT** attempt to lift in high winds.
- G. Keep all personnel out from under and away from the compressor whenever it is suspended.
- H. Lift compressor no higher than necessary.
- I. Keep lift operator in constant attendance whenever compressor is suspended.
- J. Set compressor down only on a level surface capable of supporting at least its net weight plus an additional 10% allowance for the weight of snow, ice, mud or stored tools and equipment.
- K. If the compressor is provided with parking brakes, make sure they are set, and in any event, block or chock both sides of all running wheels before disengaging the lifting hook.

1.8 ELECTRICAL SHOCK

- A. Keep the towing vehicle or equipment carrier, compressor hoses, tools and all personnel at least 10 feet (3 m) from power lines and buried cables.

1.10 ENTRAPMENT

- A. Make sure all personnel are out of compressor before closing and latching enclosure doors.
- B. If the compressor is large enough to hold a man and if it is necessary to enter it to perform service adjustments, inform other personnel before doing so, or else secure the access door in the open position to avoid the possibility of others closing and possibly latching the door with personnel inside.

1.11 JUMP STARTING

- A. Observe all safety precautions mentioned elsewhere in this manual.
- B. Batteries may contain hydrogen gas which is flammable and explosive. Keep flames, sparks and other sources of ignition away.
- C. Batteries contain acid which is corrosive and poisonous. **DO NOT** allow battery acid to contact eyes, skin, fabrics or painted surfaces as serious personal injury or property damage could result. Flush any contacted areas thoroughly with water immediately. Always wear an acid-resistant apron and face shield when attempting to jump start the compressor.
- D. Remove all vent caps (if so equipped) from the battery or batteries in the compressor. **DO NOT** permit dirt or foreign matter to enter the open cells.
- E. Check fluid level. If low, bring fluid to proper level before attempting to jump start (not applicable to maintenance-free batteries).
- F. **DO NOT** attempt to jump start if fluid is frozen or slushy. Bring batteries up to at least 60 °F (16 °C) before attempting to jump start or it may explode.
- G. Cover open cells of all compressor batteries with clean dampened cloths before attempting to jump start.
- H. Attempt to jump start only with a vehicle having a negative ground electrical system with the same voltage, and is also equipped with a battery or batteries of comparable size or larger than supplied in the compressor. **DO NOT** attempt to jump start using motor generator sets, welders or other sources of DC power as serious damage may result.
- I. Bring the starting vehicle alongside the compressor, but **DO NOT** permit metal to metal contact between the compressor and the starting vehicle.
- J. Set the parking brakes of both the compressor (if provided) and the starting vehicle or otherwise block both sides of all wheels.
- K. Place the starting vehicle in neutral or park, turn off all non-essential accessory electrical loads and start its engine.
- L. Use only jumper cables that are clean, in good condition and are heavy enough to handle the starting current.
- M. Avoid accidental contact between jumper cable terminal clips or clamps and any metallic portion of either the compressor or the starting vehicle to minimize the possibility of uncontrolled arcing which might serve as a source of ignition.
- N. Positive battery terminals are usually identified by a plus (+) sign on the terminal and the letters POS adjacent to the terminal. Negative battery terminals are usually identified by the letters NEG adjacent to the terminal or a negative (-) sign.
- O. Connect one end of a jumper cable to the positive (POS) (+) battery terminal in the starting vehicle. When jump starting 24V compressors and if the starting vehicle is provided with two (2) 12V batteries connected in series, connect the jumper cable to the positive (POS) (+) terminal of the ungrounded battery.
- P. Connect the other end of the same jumper cable to the positive (POS) (+) terminal of the starter motor battery in the compressor, or when jump starting 24V compressor, to the positive (POS) (+) terminal of the ungrounded battery in the compressor.
- Q. Connect one end of the other jumper cable to the grounded negative (NEG) (-) terminal of the battery in the starting vehicle. When jump starting 24V compressors and if the starting vehicle is provided with two (2) 12V batteries connected in series, connect the jumper cable to the negative (NEG) (-) terminal of the grounded battery.
- R. Check your connections. **DO NOT** attempt to start a 24V compressor with one 12V battery in the starting vehicle. **DO NOT** apply 24V to one 12V battery in the compressor.
- S. Connect the other end of this same jumper cable to a clean portion of the compressor engine block away from fuel lines, the crank case breather opening and the battery.
- T. Start the compressor in accordance with normal procedure. Avoid prolonged cranking.
- U. Allow the compressor to warm up. When the compressor is warm and operating smoothly at normal idle RPM, disconnect the jumper cable from the engine block in the compressor, then disconnect the other end of this same cable from the grounded negative (NEG) (-) terminal of the battery in the starting vehicle. Then disconnect the other jumper cable from the positive (POS) (+) terminal of the battery in the compressor, or if provided with two (2) 12V batteries connected in series, from the ungrounded battery in the compressor, and finally, disconnect the other end of this same jumper cable from the positive (POS) (+) terminal of the battery in the starting vehicle or from the positive (POS) (+) terminal of the ungrounded battery in the starting vehicle, if it is provided with two (2) 12V batteries connected in series.

- V. Remove and carefully dispose of the dampened cloths, as they may now be contaminated with acid, then replace all vent caps.

1.12 CALIFORNIA PROPOSITION 65

 WARNING
<p>CALIFORNIA PROPOSITION 65 WARNING</p> <p>Diesel engine exhaust and some of its constituents are known to the State of California to cause cancer, birth defects and other reproductive harm. Battery posts, terminals and related accessories contain lead and other compounds known to the State of California to cause cancer and birth defects and other reproductive harm. Wash hands after handling.</p>

1.13 IMPLEMENTATION OF LOCKOUT/TAGOUT

The energy control procedure defines actions necessary to lockout a power source of any machine to be repaired, serviced or set-up, where unexpected motion, or an electrical or other energy source, would cause personal injury or equipment damage. The power source on any machine shall be locked out by each employee doing the work except when motion is necessary during setup, adjustment or trouble-shooting.

- A.** The established procedures for the application of energy control shall cover the following elements and actions and shall be initiated only by Authorized Persons and done in the following sequence:
1. Review the equipment or machine to be locked and tagged out.
 2. Alert operator and supervisor of which machine is to be worked on, and that power and utilities will be turned off.
 3. Check to make certain no one is operating the machine before turning off the power.
 4. Turn off the equipment using normal shutdown procedure.
 5. Disconnect the energy sources:
 - a. Air and hydraulic lines should be bled, drained and cleaned out. There should be no pressure in these lines or in the reservoir tanks. Lockout or tag lines or valves.
 - b. Any mechanism under tension or pressure, such as springs, should be released and locked out or tagged.
- B. General Security**
1. The lock shall be removed by the “Authorized” person who put the lock on the energy-isolating device. No one other than the person/persons placing padlock and lockout hasp on power shall remove padlock and lockout hasps and restore power. However, when the authorized person who applied the lock is unavailable to remove it his/her Supervisor may remove padlock/padlocks and lockout hasps and restore power only if it is first:
 - a. verified that no person will be exposed to danger.
 - b. verified that the “Authorized” person who applied the device is not in the facility.
 - c. noted that all reasonable efforts to contact the “Authorized” person have been made to inform him or her that the lockout or tagout device has been removed.
 - d. ensured that the “Authorized” person is notified of lock removal before returning to work.
 2. Tagout System—Tags are warning devices affixed at points of power disconnect and are not to be removed by anyone other than the person placing tag on power lockout. Tags shall never be by-passed, ignored, or otherwise defeated.

- c. Block any load or machine part prior to working under it.
 - d. Electrical circuits should be checked with calibrated electrical testing equipment and stored energy and electrical capacitors should be safely discharged.
6. Lockout and/or Tagout each energy source using the proper energy isolating devices and tags. Place lockout hasp and padlock or tag at the point of power disconnect where lockout is required by each person performing work. Each person shall be provided with their own padlock and have possession of the only key. If more than one person is working on a machine each person shall affix personal lock and tag using a multi-lock device.
 7. Tagout devices shall be used only when power sources are not capable of being locked out by use of padlocks and lockout hasp devices. Name of person affixing tag to power source must be on tag along with date tag was placed on power source.
 8. Release stored energy and bring the equipment to a “zero mechanical state”.
 9. Verify Isolation: Before work is started, test equipment to ensure power is disconnected.

B. General Security

1. The lock shall be removed by the “Authorized” person who put the lock on the energy-isolating device. No one other than the person/persons placing padlock and lockout hasp on power shall remove padlock and lockout hasps and restore power. However, when the authorized person who applied the lock is unavailable to remove it his/her Supervisor may remove padlock/padlocks and lockout hasps and restore power only if it is first:
 - a. verified that no person will be exposed to danger.
 - b. verified that the “Authorized” person who applied the device is not in the facility.
 - c. noted that all reasonable efforts to contact the “Authorized” person have been made to inform him or her that the lockout or tagout device has been removed.
 - d. ensured that the “Authorized” person is notified of lock removal before returning to work.
2. Tagout System—Tags are warning devices affixed at points of power disconnect and are not to be removed by anyone other than the person placing tag on power lockout. Tags shall never be by-passed, ignored, or otherwise defeated.

1.14 EXPLOSIVE ATMOSPHERE

 **WARNING**

DO NOT attempt to operate the compressor in any classification of hazardous environment or potentially explosive atmosphere unless the compressor has been specially designed and manufactured for that duty.



Section 2

DESCRIPTION

2.1 INTRODUCTION

The Sullair 300HH, 375, 375H, and 425 CFM Standard and Aftercooled Portable Air Compressors offer superior performance, reliability and require a minimal amount of maintenance. Compared to other compressors, Sullair's are unique in terms of reliability and durability. Compressor internal components require no routine maintenance inspections.

2.2 DESCRIPTION OF COMPONENTS

Figure 2-1 shows the main components and subassemblies of the Sullair 300HH, 375, 375H, and 425 Standard and Aftercooled Portable Air Compressors. These packages include a **heavy duty rotary screw air compressor, a diesel engine, fuel tank, compressor**

inlet system, compressor cooling and lubrication system, compressor discharge system, capacity control system, instrument panel and electrical system. A low profile canopy offers improved handling and mobility. Large side service doors provide easy access to all serviceable components. This model meets EPA sound level regulations of 76dbA at 7 meters (23 feet). Sullair air compressors have the following delivery capacities:

Model 300HH, 300CFM @ 200 psig (13.8 bar)

Model 375, 375CFM @ 100 psig (6.9 bar)

Model 375H, 375CFM @ 150 psig (10.3 bar)

Model 425, 425CFM @ 100 psig (6.9 bar)

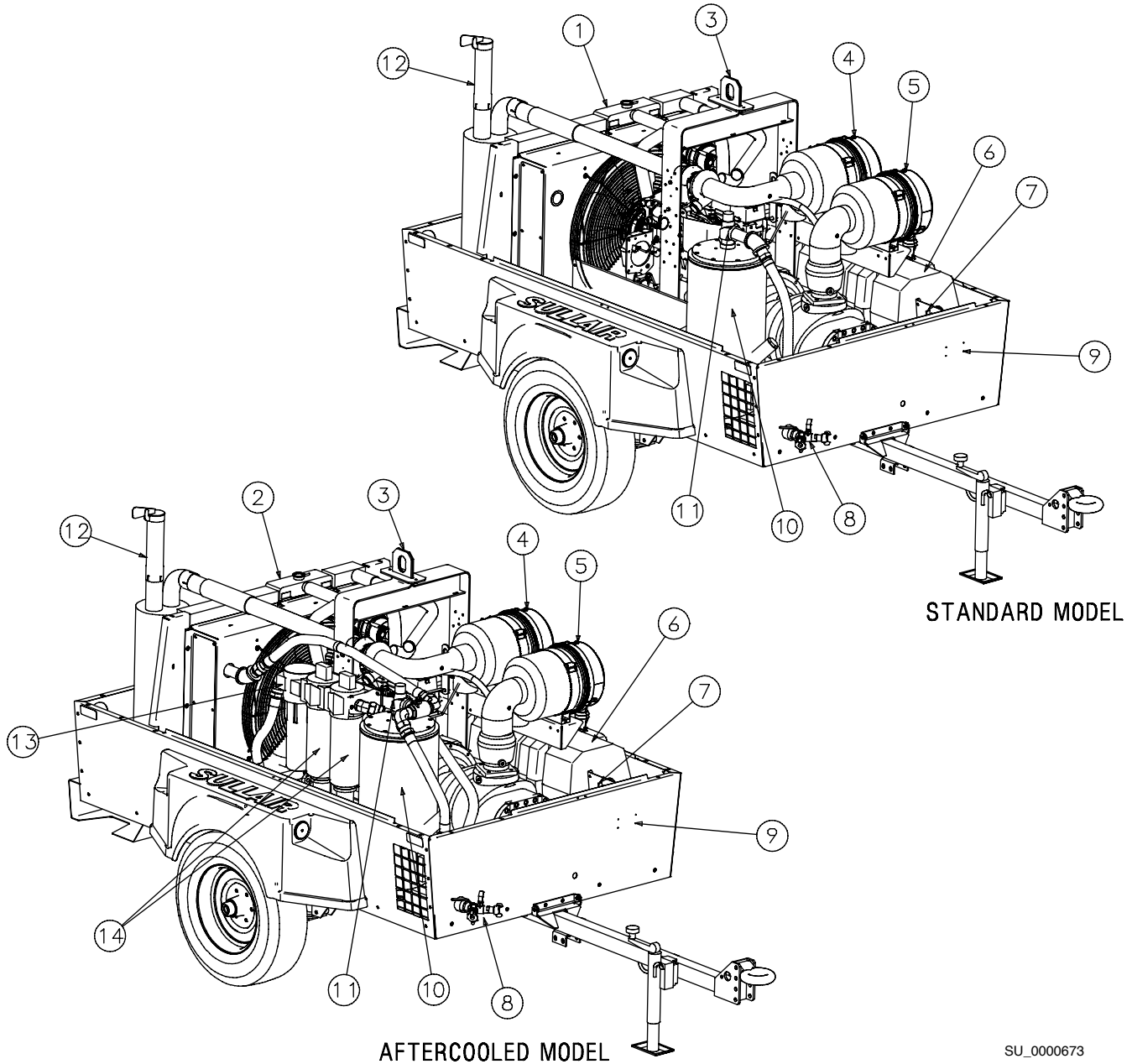

- | | |
|--|--|
| <ol style="list-style-type: none"> 1. Radiator/Fluid Cooler Assembly 2. Radiator/Fluid Cooler Assembly With Air To Air Aftercooler 3. Lifting Bail 4. Engine Air Filter 5. Compressor Air Filter 6. Fuel Tank 7. Battery Shutoff Switch | <ol style="list-style-type: none"> 8. Service Valves 9. Serial Number Plate Location 10. Receiver/Sump Tank 11. Minimum Pressure/Check Valve 12. Engine Exhaust Muffler 13. Moisture Separator 14. Optional Discharge Air Filters |
|--|--|

SU_0000673

Figure 2-1: Sullair Rotary Screw Portable Air Compressor – Caterpillar Standard and Aftercooled Models

The control system can easily be adjusted for pressures from 80 to 125 psig (5.6 to 8.6 bar) for standard machines, from 80 to 150 psig (5.6 to 10.3 bar) for “H” machines and from 80 psig to 200 psig (5.6 to 13.8 bar) for “HH” machines. The compressor unit is driven by an industrial diesel engine designed to provide enough horsepower to provide an adequate reserve under rated conditions.

Refer to the **Engine Operator’s Manual** for a more detailed description of the engine. The engine cooling system is comprised of a radiator, charge air cooler, high capacity fan, and thermostat. The high capacity fan pushes air through the radiator to maintain the engine’s specified operating temperature. The same fan also cools the fluid in the compressor cooling and lubrication system.

The engine radiator, charge air cooler, and the compressor fluid cooler are next to each other allowing the fan air to push through all three simultaneously. As air passes through the fluid cooler, the heat of compression is removed from the fluid. The compressor's high capacity fuel tank contains enough fuel for one eight hour shift under normal operating conditions.

2.3 SULLAIR COMPRESSOR UNIT, FUNCTIONAL DESCRIPTION

Sullair compressors are single-stage, positive displacement, flood lubricated-type compressors that provide continuous (pulse-free) compression to meet various demand loads. Sullair compressors require no routine maintenance or inspection of their internal parts or systems. The compressor works by injecting fluid into the compressor unit where it mixes directly with the air as the rotors turn: the rotor's rotation compresses the air. The fluid flow has three main functions:

1. It acts as a coolant, to control the rise of air temperature which is generated by compression (heat of compression).
2. Seals the leakage paths between the rotors and the stator and also between the rotors themselves.
3. Lubricates the rotors allowing one rotor to directly drive the other.

After the air fluid mixture is discharged from the compressor unit, the fluid is separated from the air. At this time, the air flows to the service line and the fluid is cooled in preparation for re-injection.

2.4 COMPRESSOR COOLING AND LUBRICATION SYSTEM, FUNCTIONAL DESCRIPTION

Refer to *Figure 2-2*. The compressor cooling and lubrication system is designed to provide adequate lubrication as well as maintain the proper operating temperature of the compressor. In addition to the fluid cooler and interconnecting piping, the system consists also of three other components: a fluid filter, thermal valve, and a fan which perform the following functions:

- The fluid filter removes and collects any contaminants in the fluid.
- The thermal valve functions as a temperature regulator directing fluid either to the cooler or to the compressor unit.
- The fan pushes air through the cooler dissipating the heat resulting from compression of the fluid.

The functions of the lubrication system are explained in more detail below. Fluid is used in the system as a coolant and as a lubricant: the sump serves as the fluid reservoir. At start-up, fluid flows from the sump to the fluid thermal valve. Fluid circulation is achieved by forcing the fluid from

the high pressure region of the sump to a lower pressure area in the compressor unit. A minimum pressure device (See *Compressor Discharge System, Functional Description on page 14*) is provided to assure adequate fluid flow under all conditions. When entering the thermal valve upon start-up, the fluid temperature is cool and thus it is not necessary to route it through the cooler. The fluid flows through the fluid filter and on to the compressor unit bypassing the cooler. As the compressor continues to operate, the temperature of the fluid rises and the thermostatic control opens, allowing a portion of the fluid into the cooler.

When the temperature reaches 155°F (68°C), the thermostat is fully open allowing all fluid entering the thermal valve to flow to the cooler.

The cooler is a radiator type that works in concert with the engine fan. The fan pushes air through the cooler removing the heat from the fluid. From the cooler, the fluid is then routed back through the fluid filter. All fluid flowing to the compressor unit passes through this filter. The fluid leaving the filter flows to the compressor unit where it lubricates, seals and cools the compression chamber; and lubricates the bearings and gears.

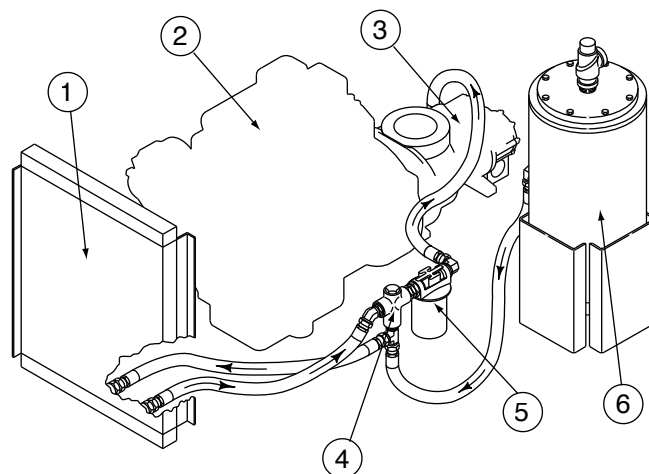

SU_0000664

1. Fluid Cooler
2. Engine
3. Compressor
4. Thermal Valve
5. Fluid Filter
6. Receiver Tank

Figure 2-2: Compressor Cooling and Lubrication System

2.5 COMPRESSOR DISCHARGE SYSTEM, FUNCTIONAL DESCRIPTION

Refer to *Figure 2-3*. The Sullair compressor unit discharges a compressed air/fluid mixture into the sump. The sump has three functions:

1. It acts as a primary fluid separator.
2. Serves as the compressor fluid reservoir.
3. Houses the air/fluid separator.

The compressed air/fluid mixture enters the sump and is directed against the side of the sump. Because of a change of direction and reduction of velocity, large droplets of fluid separate and fall to the bottom of the sump. The small amount of fluid remaining in the compressed air collects on the surface of the separator element as the compressed air flows through the separator. As more fluid collects on the element surface, it then flows to the bottom of the separator. A return line (or scavenge tube) leads from the bottom of the separator element to the inlet region of the compressor unit. Fluid collecting on the bottom of the separator element is returned to the compressor by the pressure difference between the area surrounding the separator element and the compressor inlet. An orifice (protected by a strainer) is included in this return line to assure proper and unobstructed flow. The sump is ASME code rated at 250 psig (17.1 bar) working pressure. A minimum pressure device located downstream from the separator, ensures a minimum receiver pressure of 80 psig (5.5 bar) during all conditions. Keeping this pressure level stable is necessary for proper air/fluid separation and proper fluid circulation. A pressure relief valve (located on the wet side of the separator) is set to open if the sump pressure exceeds 250 psig (17.1 bar).

Fluid is added to the sump through a capped fluid filler.

WARNING

DO NOT remove caps, plugs and/or other components when the compressor is running or pressurized. Stop the compressor and relieve all internal pressure before removing these items.

2.6 CAPACITY CONTROL SYSTEM, FUNCTIONAL DESCRIPTION

Refer to *Figure 2-4*, *Figure 2-5*, *Figure 2-6* or *Figure 2-7*. The purpose of the control system is to regulate the amount of air intake and match it to the demand (required output) on the compressor. The control system consists of a pressure regulating valve(s), air inlet valve, system blowdown valve, pressure transducer, speed control module, and tubing connecting the various components of the compressor and engine. The functional descriptions of the control system are described by relating them to four distinct phases of operation. They apply to any control system with the exception of those with specified pressures which are dependent on pressure requirements. The given values apply to a compressor with an operating pressure range of 100 to 110 psig (6.9 to 7.6 bar).

Start – 0 To 40 psig (0 To 2.8 Bar) Cold Start

When the compressor is started, the sump pressure quickly rises from 0 to 40 psig (0 to 2.8 bar). During this period the pressure regulator valve is inactive. At this pressure range the idle warm-up control keeps the inlet valve closed for engine idle operation. Within 30 seconds of starting the compressor (the instrument panel annunciator light goes off after 30 seconds) turn the handle of the warm-up selector valve (located on the instrument panel) from the START to the RUN position. The inlet valve is fully open due to inlet pressure, and the compressor operates at full capacity. When the compressor operates at full capacity, the engine runs at full speed.

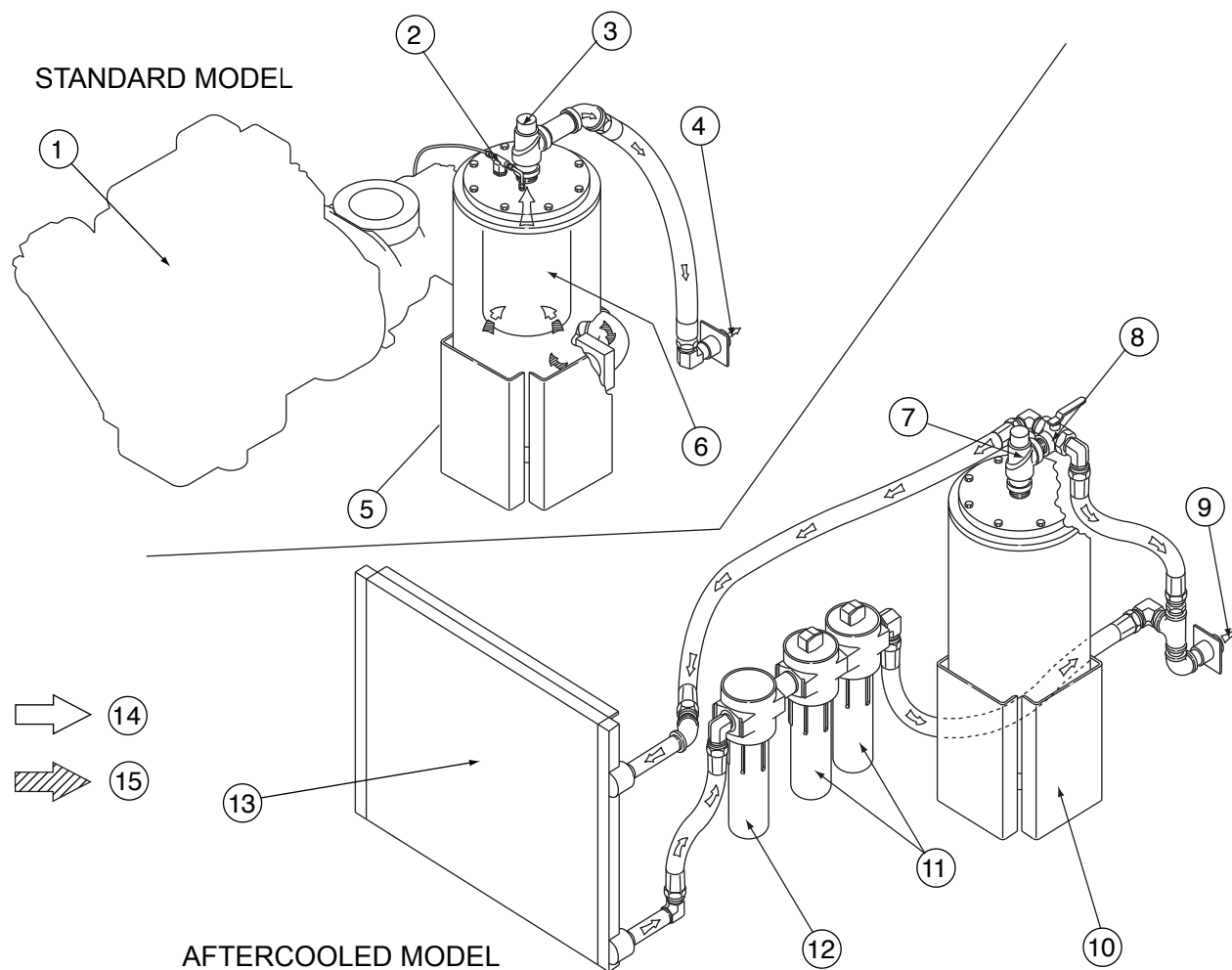

SU_0000665

- | | |
|--|------------------------------------|
| 1. Engine | 9. Service Air Outlet |
| 2. Strainer | 10. Receiver Tank (Sump) |
| 3. Minimum Pressure/Check Valve | 11. Optional Discharge Air Filters |
| 4. Service Air Outlet | 12. Moisture Separator |
| 5. Receiver Tank (Sump) | 13. Aftercooler |
| 6. Separator Element | 14. Air |
| 7. Minimum Pressure Valve | 15. Fluid/Air |
| 8. Non-Aftercooled/Aftercooled Service Air Valve | |

Figure 2-3: Compressor Discharge System – Standard and Aftercooled Models

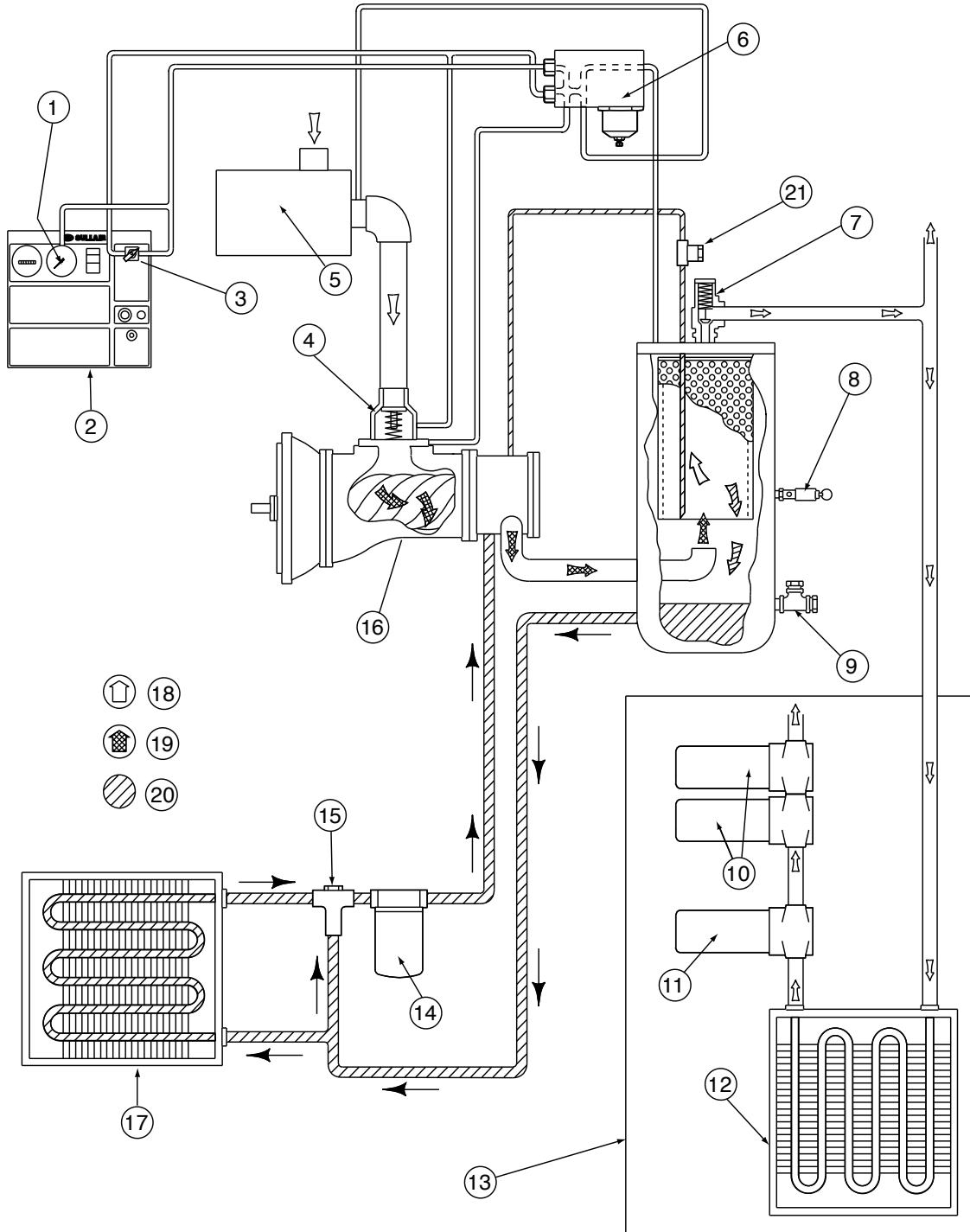

SU_0000666

- | | |
|---------------------------------------|-------------------------------|
| 1. Air Pressure Gauge | 12. Optional Aftercooler |
| 2. Instrument Panel | 13. Aftercooled Machines ONLY |
| 3. Idle Warm-Up Valve | 14. Fluid Filter |
| 4. Inlet Valve | 15. Thermal Valve |
| 5. Air Filter | 16. Compressor Unit |
| 6. Regulator/Blowdown Valve Manifold | 17. Fluid Cooler |
| 7. Minimum Pressure Check Valve | 18. Air |
| 8. Pressure Relief Valve | 19. Fluid/Air |
| 9. Fluid Fill/Fluid Level Sight Glass | 20. Fluid |
| 10. Optional Discharge Air Filters | 21. Strainer |
| 11. Optional Moisture Separator | |

Figure 2-4: Control System with Piping and Instrumentation - 375 and 425 Models

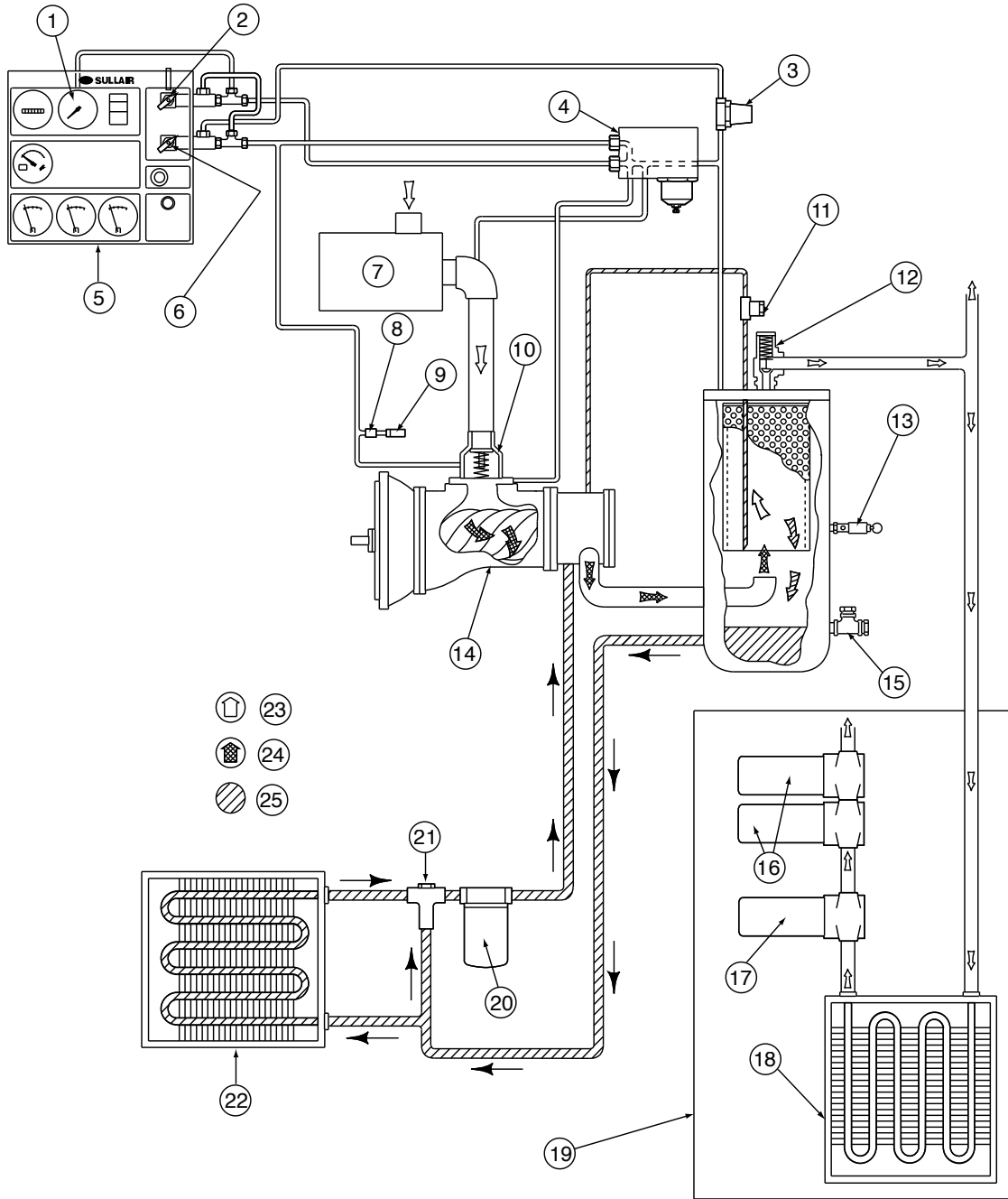

SU_0000667

- | | |
|--|--|
| 1. Air Pressure Gauge | 14. Compressor Unit |
| 2. Idle Warm-Up Control Selector Valve | 15. Fluid Fill/Fluid Level Sight Glass |
| 3. Low Pressure Regulator Valve | 16. Optional Discharge Air Filters |
| 4. High Pressure Regulator/Blowdown Valve Manifold | 17. Optional Moisture Separator |
| 5. Instrument Panel | 18. Optional Aftercooler |
| 6. High/Low Pressure Selector Switch | 19. Aftercooled Machines ONLY |
| 7. Air Filter | 20. Fluid Filter |
| 8. Orifice | 21. Thermal Valve |
| 9. Silencer | 22. Fluid Cooler |
| 10. Inlet Valve | 23. Air |
| 11. Strainer | 24. Fluid/Air |
| 12. Minimum Pressure/Check Valve | 25. Fluid |
| 13. Pressure Relief Valve | |

Figure 2-5: Control System with Piping and Instrumentation – 300HH and 375H Models

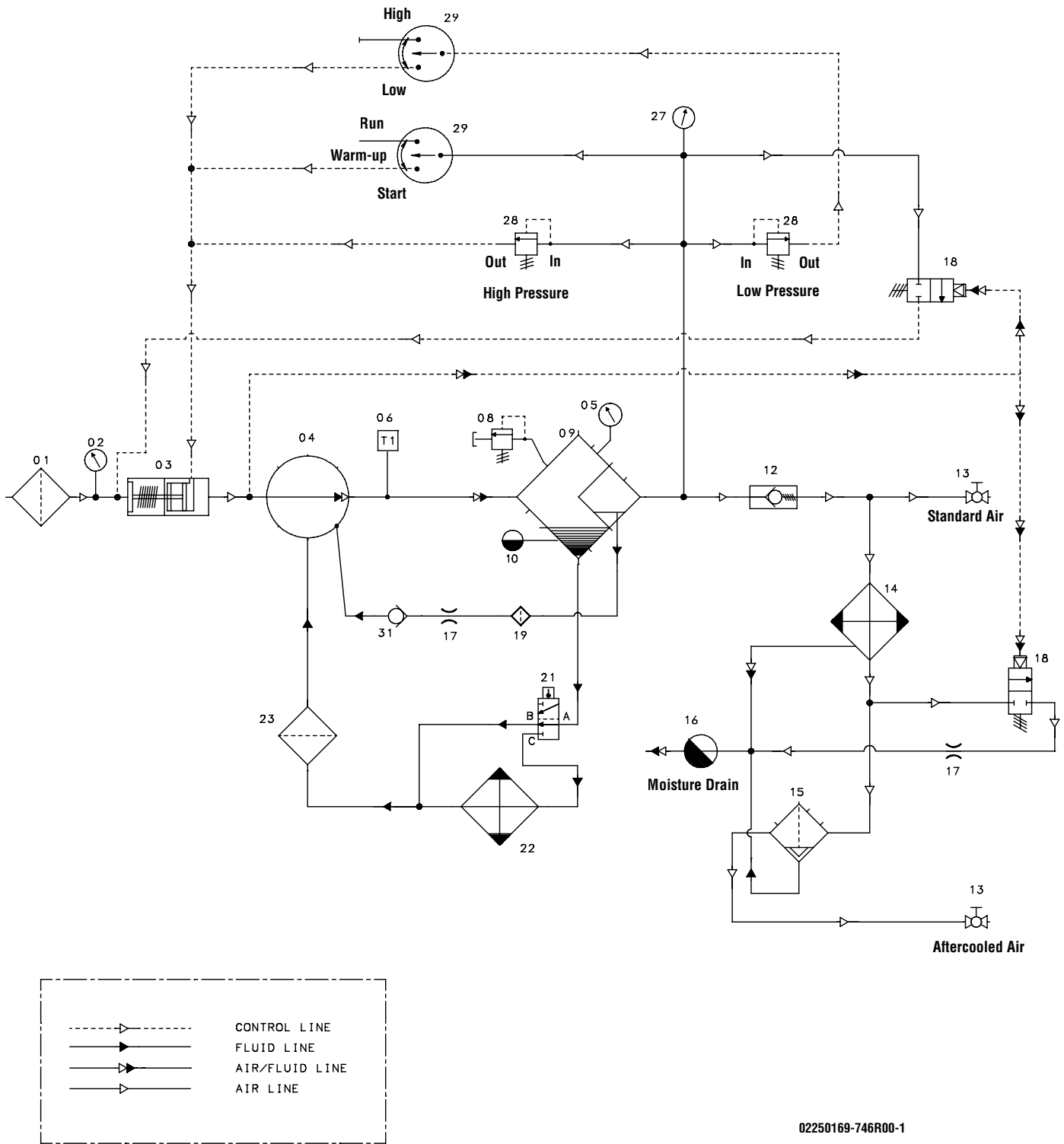

Figure 2-6: Piping and Instrumentation Diagram

1.	Filter, Air	T1	Compressor Discharge Temperature Switch
2.	Gauge, Filter Restriction (Optional)		
3.	Inlet Valve		
4.	Compressor		
5.	Gauge, Temperature		
6.	Switch, Temperature		
8.	Valve, Relief		
9.	Receiver, Air/Oil		
10.	Glass, Sight Oil Level		
11.	Indicator, Delta-P		
12.	Valve, Minimum Pressure/Check		
13.	Valve, Ball		
14.	Cooler, Air		
15.	Separator, Moisture		
16.	Trap, Drain		
17.	Orifice		
18.	Valve, Blowdown N.C.		
19.	Strainer		
21.	Valve, Thermal Bypass		
22.	Cooler, Oil		
23.	Filter, Oil		
27.	Gauge, Pressure		
28.	Valve, Pressure Regulator		
29.	Valve, 3-Way Selector		
31.	Valve, Check		

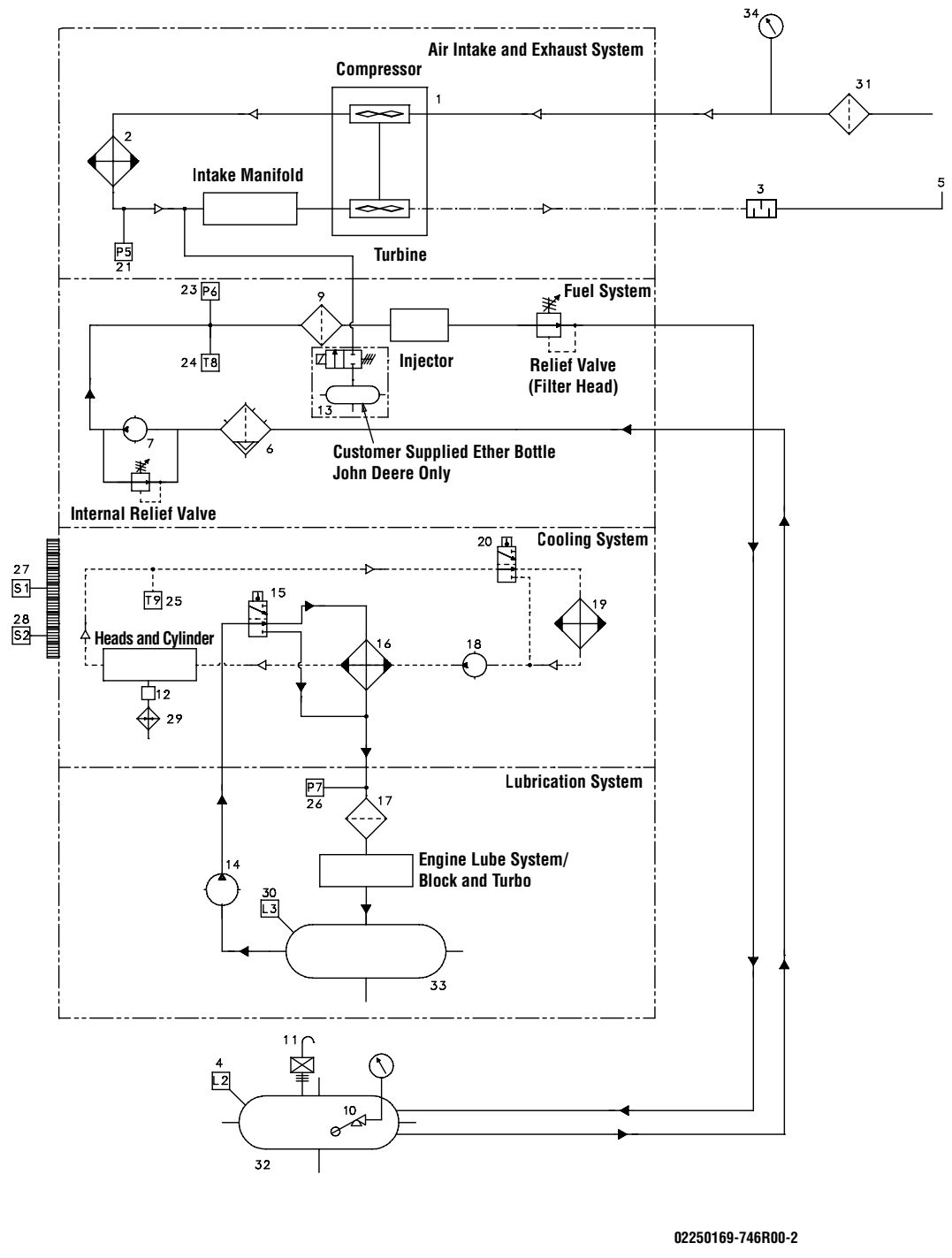
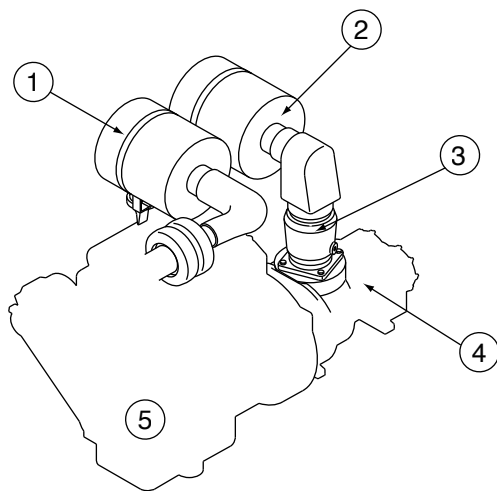

Figure 2-7: Piping and Instrumentation Diagram

1.	Turbocharger, Compressor	L1	Coolant Level
2.	Cooler, Air	L2	Fuel Level
3.	Muffler, Engine	L3	Oil Level (Dipstick)
4.	Fuel Level Sender	P5	Inlet Manifold Air Pressure
5.	Rain Cap, Exhaust System	P6	Fuel Pressure
6.	Fuel Filter W/ Water Separator	P7	Oil Pressure
7.	Fuel Transfer Pump (Internal To Engine)	T8	Fuel Temperature
8.	Hand Operated Fuel Priming Pump	T9	Coolant Temperature
9.	Filter, Fuel	S1	Cam Speed
10.	Gauge, Fuel Level	S2	Crank Speed
11.	Fuel Tank Cap W/Vent		
12.	Thermostat, Thermocord (Optional)		
13.	Kit, Ether Assembly		
14.	Oil Pump (Integral To Engine)		
15.	By-Pass Valve (Internal To Engine)		
16.	Cooler, Oil (Internal To Engine)		
17.	Filter, Oil		
18.	Water Pump (Integral To Engine)		
19.	Radiator, Engine		
20.	Engine Thermostat (Integral To Engine)		
21.	Inlet Manifold Air Press Sensor (Turbo Boost)		
23.	Sensor, Fuel Pressure		
24.	Sensor, Fuel Temperature		
25.	Sensor, Coolant Temperature		
26.	Sensor, Engine Oil Pressure		
27.	Sensor, Cam Speed Timing		
28.	Sensor, Crank Speed Timing		
29.	Jacket Water Heater (Optional)		
30.	Oil Level (Dipstick)		
31.	Filter, Air		
32.	Tank, Fuel		
33.	Engine Oil Pan		
34.	Gauge, Filter Restriction		



SU_0000668

1. Engine Air Filter
2. Compressor Air Filter
3. Air Inlet Valve
4. Compressor
5. Engine

Figure 2-8: Air Inlet System – Caterpillar

Normal Operation – 80 to 100 psig (5.6 to 6.9 bar) or 80 to 150 psig (5.6 to 10.3 bar) for H machines or 80 to 200 psig (5.6 to 13.8 bar) for HH machines

When the warm-up control selector valve handle is moved to the RUN position, the sump pressure rises above 80 psig (5.6 bar). At this time, the inlet valve remains fully open for maximum air output. The engine will continue to run at full speed during this phase of operation.

Modulation – 100 to 110 psig (6.9 to 7.5 bar) or 150 to 165 psig (10.3 to 11.4 bar) for H machines or 200 to 220 psig (13.8 to 15.2 bar) for HH machines

If the demand on the compressor is less than its rated capacity, the service line pressure will rise above 100 psig (6.9 bar) - low or single pressure rating: 150 psig (10.3 bar) for “H” rating or 200 psig (13.8 bar) for “HH” dual or high pressure rating. The pressure regulating valve gradually opens, applying pressure to the inlet valve piston and pressure transducer. This causes the inlet valve to partially close and reduces the engine speed. As the

pressure increases, the inlet valve piston will further close the inlet valve and the engine speed will decrease until it reaches its preset idle speed. When the demand on the compressor increases, the sump pressure falls below 110 psig (7.6 bar) or 165 psig (11.4 bar) for “H” machines, or 220 psig (15.2 bar) for “HH” ones. The pressure regulating valve closes, the air inlet valve opens fully, and the engine speed increases to its preset full load rating.

Between the pressure regulating valve and the inlet valve, there is a small orifice that vents a small amount of air into the atmosphere when the pressure regulating valve is open. This allows changes in air output to conform to air demand. This orifice also discharges any accumulated moisture from the regulator.

Shutdown

The blowdown valve is normally closed. At shutdown the back pressure in the compressor inlet signals the blowdown valve to vent the sump pressure into the atmosphere.

2.7 AIR INLET SYSTEM, FUNCTIONAL DESCRIPTION

Refer to *Figure 2-8*. The air inlet system consists of two air filters, a compressor air inlet valve and interconnecting piping to the engine and the compressor.

The air filters are three-stage dry element type filters that are capable of cleaning extremely dirty air. However, when operating in dirty environments, the filters should be checked more frequently.

See *Air Filter Maintenance on page 61* for Air Filter Maintenance Procedures.

2.8 INSTRUMENT PANEL GROUP, FUNCTIONAL DESCRIPTION

Refer to *Figure 2-9*. The instrument panel group consists of a molded panel containing an: air pressure gauge, compressor temperature gauge (optional), ignition/start switch, PowerView (optional), annunciator light, idle warm-up control, engine shutdown light, engine warning light, and a wait to start light. A high-low pressure selector valve is located on the panel for “H” and “HH” compressors.

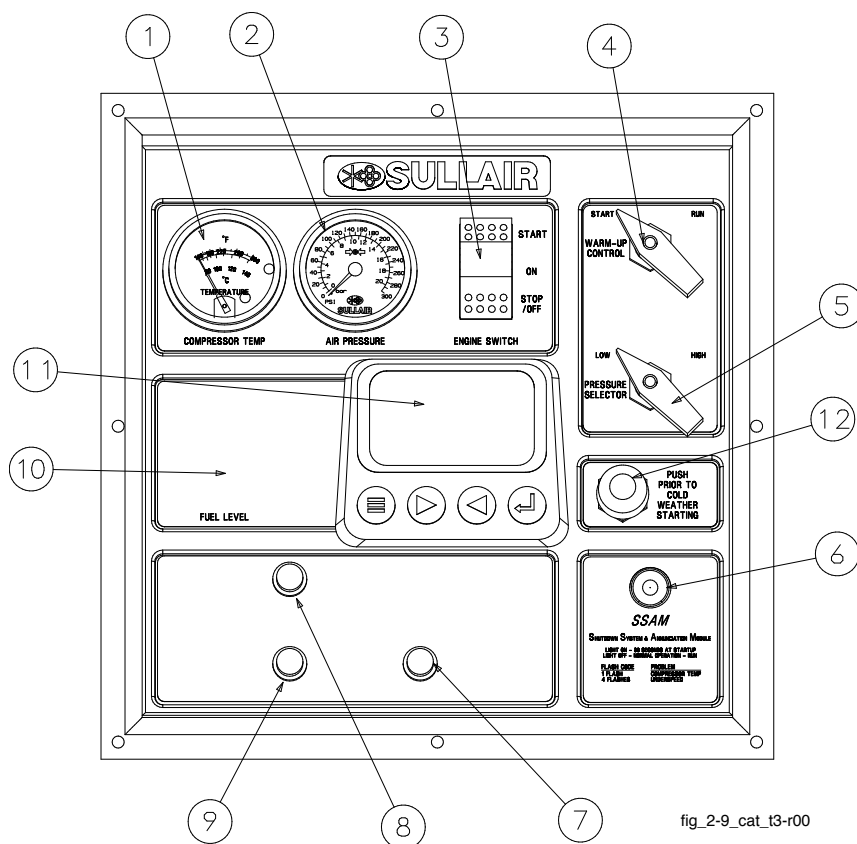

fig_2-9_cat_13-r00

- | | |
|--|---|
| 1. Compressor Discharge Temperature Gauge (optional) | 7. Engine Warning Lamp |
| 2. System Air Pressure Gauge | 8. Engine Wait to Start Lamp |
| 3. Start/Stop Switch | 9. Engine Stop Lamp |
| 4. Warm-up Control Switch | 10. Fuel Level (optional) |
| 5. High/Low Pressure Selector Switch | 11. Engine PowerView Monitor (optional) |
| 6. Shutdown Indicator | 12. Cold Weather Starting Aid |

Figure 2-9: Instrument Panel Group (Optional Full Gauge Panel Shown)

Refer to *Figure 2-9* for the locations of the following indicators and controls:

- The compressor discharge temperature gauge monitors the temperature of the air/oil mixture in the sump.
- The air pressure gauge continuously monitors the sump pressure under various load conditions.
- The engine switch energizes the system and starts the compressor. The engine switch is pressed to the ON position to energize the electrical system, and pressed momentarily to the START position to engage the starter and start the compressor.
- The idle warm-up control is turned from START to RUN after sufficient warm-up is achieved for full compressor operation.
- The pressure selector valve on “H” compressors allows the selection of the compressor operating pressure range, 80 to 110 psig (5.6 to 7.6 bar) or 80 to 165 psig (5.6 to 11.4 bar) for “H” models, or 80 to 220 psig (5.6 to 15.2 bar) for “HH” models.
- The shutdown indicator light indicates engine and compressor safety shutdown status.
- The engine warning lamp indicates when an abnormal condition exists. It is not necessary to shutdown the engine immediately, but the problem should be corrected as soon as possible.
- The engine wait to start lamp is illuminated when conditions are not right for starting.
- The engine stop lamp signals when the engine should be stopped immediately or as soon as possible to prevent engine damage. Correct the problem before restarting.
- The fuel level gauge indicates the fluid level in the fuel tank.
- The PowerView® is a multifunction tool that allows operators to view a wide range of engine parameters and engine service codes.
- The **cold weather starting aid** can be used to add additional glow plug time in cold weather. Press the

Continued on next page.

button and hold for 10-30 seconds (depending upon ambient temperature). Release the button prior to starting.

The engine ECM (Electronic Control Module) will monitor the engine temperature and automatically power the glow plugs upon starting in cold weather. When glow plugs are required, when the engine start switch is pressed on the ON position, the amber "Wait to Start" warning lamp will light. Leave the engine switch in the ON position until the warning light for the glow plugs is extinguished. When the "Wait to start" warning light for the glow plugs is extinguished press the engine switch to the START position in order to engage the electric starting motor and crank the engine.

NOTE

The operating period of the warning light for the glow plugs will change due to the temperature of the engine.

WARNING

DO NOT use aerosol types of starting aids such as ether.

Such use could result in an explosion and personal injury.

If the engine fails to start within 30 seconds, release the starter switch or button and wait two minutes to allow the starting motor to cool before attempting to start the engine again.

Indicator Lamps

The indicator lamps are designed to display the maximum amount of information on the minimum number of lamps. Three lamps are installed; the red "Stop" lamp, the amber "Warning" lamp and the amber "Wait to start" lamp. The "Stop" lamp and the "Warning" lamp can also be used to indicate a diagnostic code by use of the "Flash Code" feature. The "Flash Code" feature can be used to indicate all active diagnostic codes and logged diagnostic codes.

Functions of the Indicator Lamps

Stop Lamp

Lamp check - When the engine switch is turned to ON, the lamp will come on for 2 seconds. The lamp will then go off unless there is an active warning.

Flashing - The lamp will be flashing when a derate is active or when a derate is present because of an active diagnostic code. An example of an active diagnostic code is "System Voltage High".

On - The lamp will be on when the shutdown level in the engine protection strategy has been reached. The "Warning" lamp will also be on.

Warning Lamp

Lamp Check - When the engine switch is turned to ON, the lamp will come on for 2 seconds. The lamp will then go off unless there is an active warning.

Flashing - The lamp will be flashing when a "warning" or a "warning and derate" is active. This includes low oil pressure.

On - The lamp will be on when the shutdown level has been reached. The "Stop" lamp will also be on.

Wait to Start Lamp

Lamp Check - When the engine switch is turned to ON, the lamp will come on for 2 seconds. The lamp will then go off unless "Wait to Start" is active.

Flashing - The lamp is on during a "Wait to Start" period.

Using the Optional Diagnostic Gauge to Access Engine Information

Refer to *Figure 2-10*. The diagnostic gauge (*Figure 2-10, [1]*) displays engine function and trouble codes (DTCs). The display can be set for either English or metric units. It is linked to the electronic control system sensors and allows the operator to monitor engine functions and troubleshoot malfunctions.

Press the menu key (*Figure 2-10, [2]*) to view various engine functions in sequence. The following is a list of engine parameters the gauge can display:

- Engine hours
- Engine rpm
- System voltage
- Percent engine load at current rpm
- Coolant temperature
- Oil pressure
- Throttle position
- Intake manifold temperature
- Current fuel consumption
- Active service (diagnostic) codes
- Stored service (diagnostic) codes from the engine
- Set units for display
- View the engine configuration parameters

NOTE

Engine parameters that can be displayed depend upon the engine application. Six readout languages are available and can be selected during gauge setup. The diagnostic gauge has a graphical backlit Liquid Crystal Display (LCD) screen. The display can show a single parameter or four simultaneously (in four quadrants). Two arrow keys (*Figure 2-10, [3]*) scroll through the engine parameter list and menu items. The enter key (*Figure 2-10, [4]*) selects items. The red (*Figure 2-10, [5]*) and amber (*Figure 2-10, [6]*) lights alert the operator to an active trouble code condition.

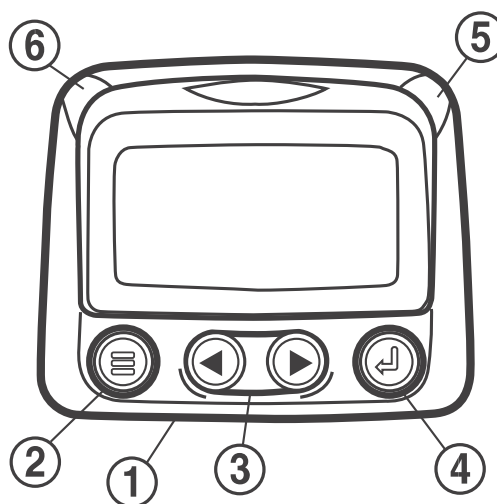

SU_0000687

1. Diagnostic Gauge
2. Menu Key
3. Arrow Keys
4. Enter Key
5. Red STOP ENGINE Indicator Light
6. Amber WARNING Indicator Light

Figure 2-10: Diagnostic Gauge

NOTE

When viewing engine codes through the PowerView, the SSAM will display a four flash fault code after 30 seconds.

POWerview OPERATION

PowerView Menus

First Time Start Up

1. When power is first applied to the PowerView, the "Logo Screen" will be displayed.

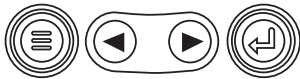

2. The "Wait to Start" message will be displayed for engines with a pre-startup sequence. Once the "Wait to Start" message is no longer displayed the operator may start the engine. Note: Displays only when SAE J1939 message is supported by engine manufacturer.

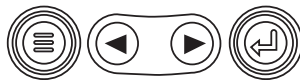

3. Once the engine has started the display will show the single engine parameter display.

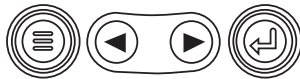
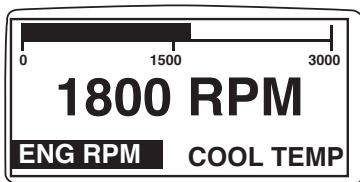

Main Menu Navigation

1. Starting at the single or four engine parameter display, depress the "Menu Button".

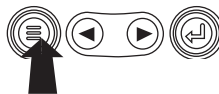
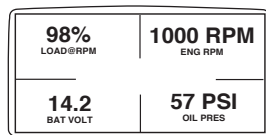
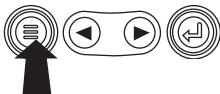
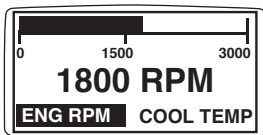

2. The first seven items of the "Main Menu" will be displayed.

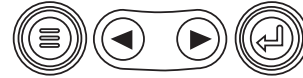
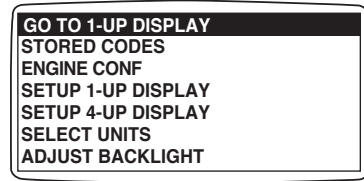

3. Depressing the "Arrow Buttons" will scroll through the menu selections.

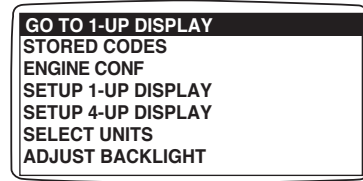

4. Pressing the right arrow button will scroll down to reveal the last items of "Main Menu" screen highlighting the next item down.

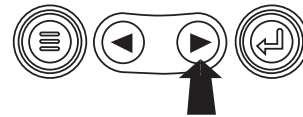
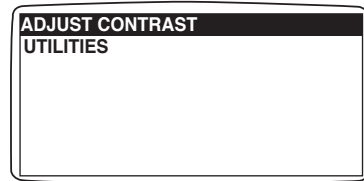

5. Use the arrow buttons to scroll to the desired menu item or press the "Menu Button" to exit the Main menu and return to the engine parameter display.

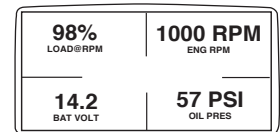
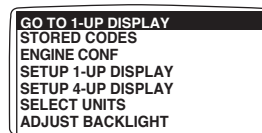

POWerview OPERATION *continued*

Stored Fault Codes

1. Starting at the single or four engine parameter display depress the "Menu Button".

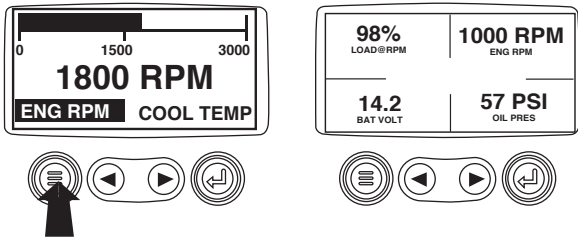

2. The main menu will pop up on the display. Use the "Arrow Buttons" to scroll through the menu until the "Stored Fault Codes" is highlighted.

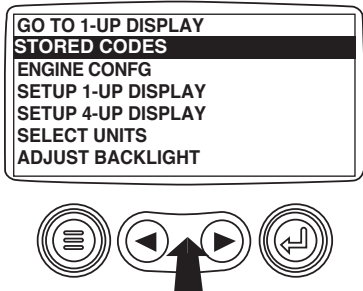

3. Once the "Stored Fault Codes" menu item has been highlighted press the "Enter Button" to view the "Stored Fault Codes".

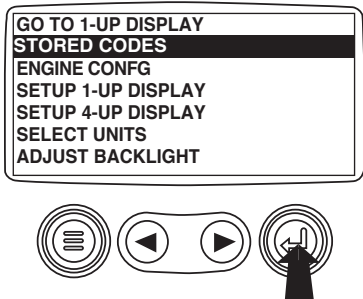

4. If the word "MORE" appears above the "Arrow Buttons" there are more stored fault codes that may be viewed. Use the "Arrow Buttons" to scroll to the next Stored Diagnostic Code.

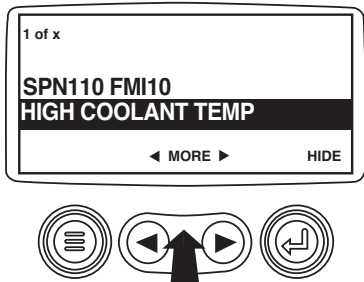

5. Press the "Menu Button" to return to the main menu.

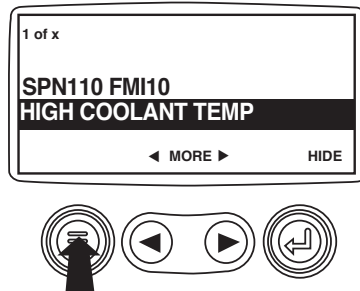

6. Press the "Menu Button" to exit the Main menu and return to the engine parameter display.

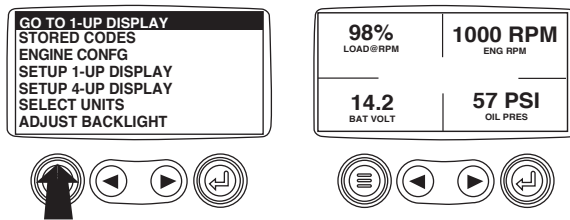

Engine Configuration Data

1. Starting at the single or four engine parameter display press the "Menu Button".

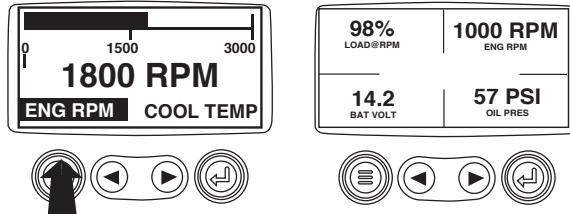

2. The main menu will pop up on the display. Use the "Arrow Buttons" to scroll through the menu until the "Engine Configuration" is highlighted.

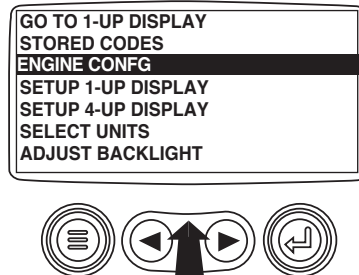

3. Once the "Engine Configuration" menu item has been highlighted press the "Enter Button" to view the engine configuration data.

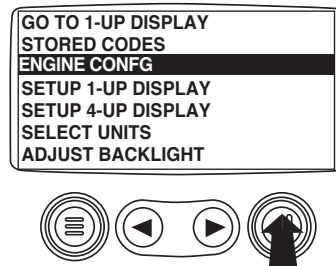

POWerview OPERATION *continued*

4. Use the "Arrow Buttons" to scroll through the engine configuration data.

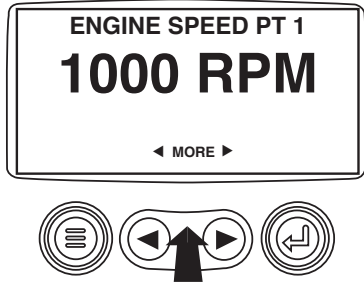

5. Press the "Menu Button" to return to the main menu.

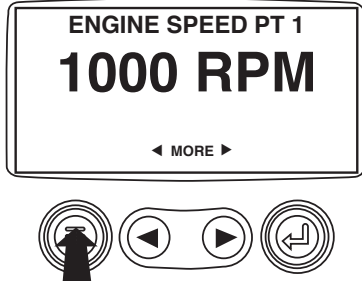

6. Press the "Menu Button" to exit the Main menu and return to the engine parameter display.

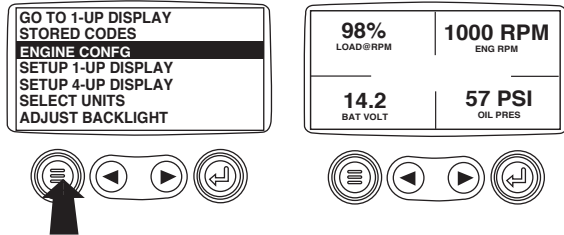

Faults and Warnings

Auxiliary Gage Fault

1. During normal operation the single or four parameter screen will be displayed.

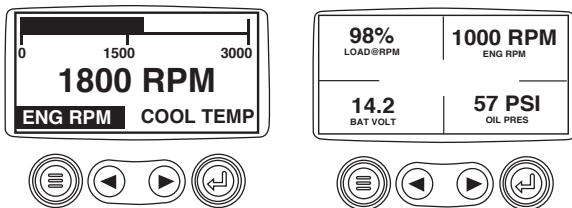

2. The PVA Series of auxiliary gages can be attached to the PowerView. These auxiliary gages communicate with the Modbus master PowerView via a daisy-chained RS-485 port. If at any time during system initialization

or normal operation an auxiliary gage should fail the single or four parameter screen will be replaced with the "MLink Gage Fault" message.



3. To acknowledge and "Hide" the fault and return to the single or four parameter display press the "Enter Button".



4. The display will return to the single or four parameter screen.

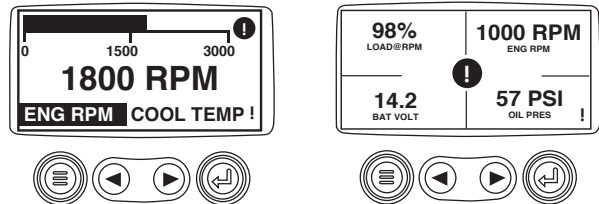

- Indicates Auxiliary Gage Fault
- Indicates Fault Warning
- Indicates Derate or Shutdown Condition Fault

5. Pressing the "Enter Button" will redisplay the hidden fault. Pressing the "Enter Button" once again will hide the fault and return the screen to the single or four parameter display. NOTE: The fault can only be cleared by correcting the cause of the fault condition.



POWerview OPERATION *continued*

Active Fault Codes

1. During normal operation the single or four parameter screen will be displayed.

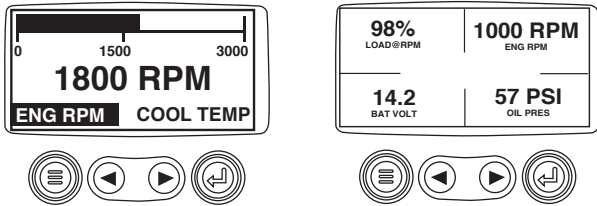

2. When the PowerView receives a fault code from an engine control unit the single or four parameter screen will be replaced with the "Active Fault Codes" message.

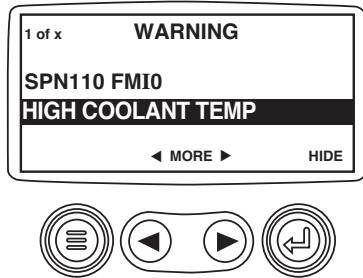

3. If the word "MORE" appears above the "Arrow Buttons" there are more active fault codes that may be viewed. Use the "Arrow Buttons" to scroll to the next "Active Fault Code"

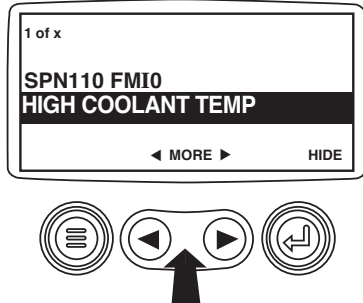

4. To acknowledge and "Hide" the fault and return to the single or four parameter display press the "Enter Button".

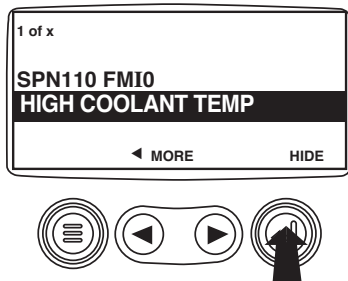

5. The display will return to the single or four parameter display, but the display will contain the "Active Fault" warning icon. Pressing the "Enter Button" will redisplay the hidden fault.

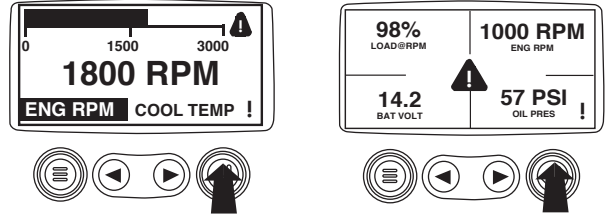

6. Pressing the "Enter Button" once again will hide the fault and return the screen to the single or four parameter display.

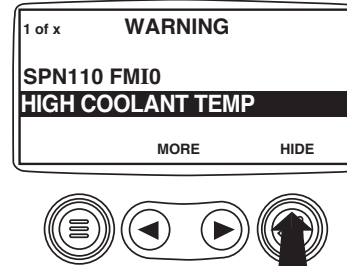

7. The Single or Four parameter screen will display the fault icon until the fault condition is corrected. NOTE: Ignoring active fault codes could result in severe engine damage.

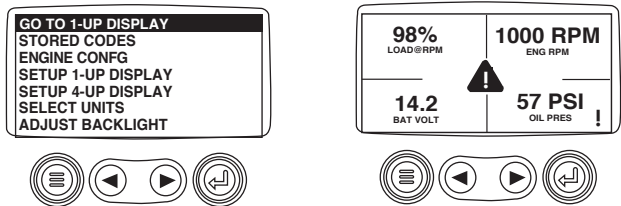

Shutdown Codes

1. During normal operation the single or four parameter screen will be displayed.

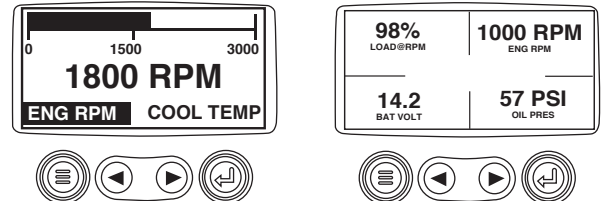

2. When the PowerView receives a severe fault code from an engine control unit the single or four parameter screen will be replaced with the "Shutdown!" message.

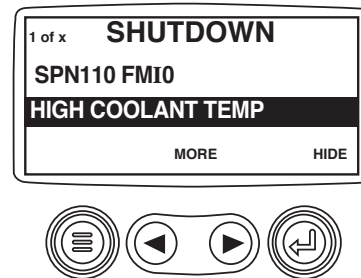

POWerview OPERATION *continued*

3. To acknowledge and "Hide" the fault and return to the single or four parameter display press the "Enter Button".

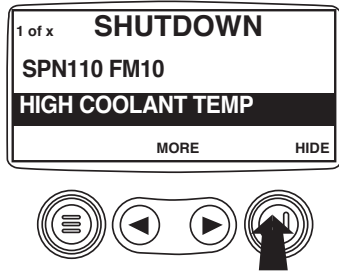

4. The display will return to the single or four parameter display, but the display will contain the "Shut Down" icon. Pressing the "Enter Button" will redisplay the hidden fault.

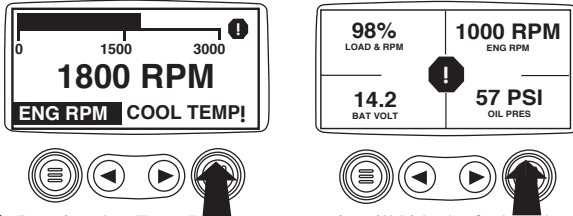

5. Pressing the "Enter Button" once again will hide the fault and return the screen to the single or four parameter display.

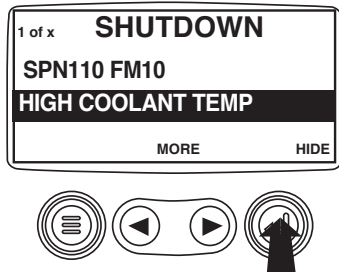

6. The Single or Four parameter screen will display the fault icon until the fault condition is corrected. NOTE: Ignoring active fault codes could result in severe engine damage.

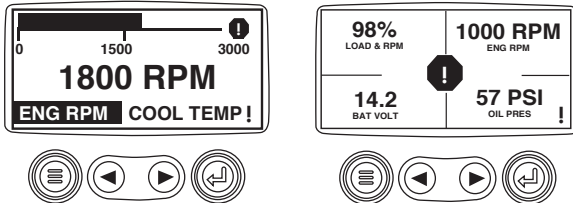

Back Light Adjustment

1. Starting at the single or four engine parameter display press the "Menu Button".

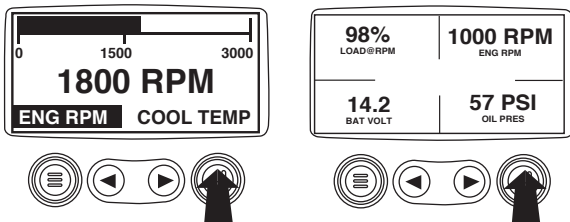

2. The main menu will pop up on the display. Use the "Arrow Buttons" to scroll through the menu until the "Adjust Backlight" is highlighted.

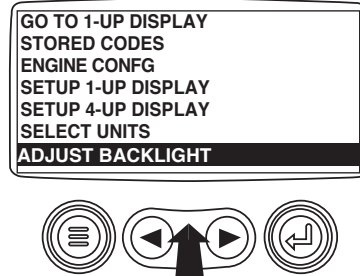

3. Once the "Adjust Backlight" menu item has been highlighted press the "Enter Button" to activate the "Adjust Backlight" function.

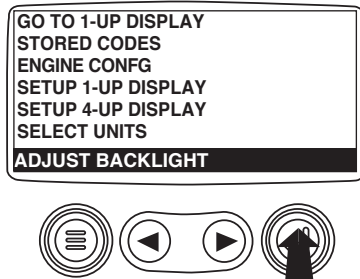

4. Use the "Arrow Buttons" to select the desired backlight intensity.

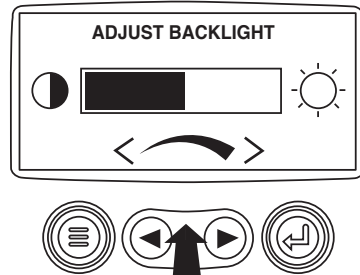

5. Press the "Menu Button" to return to the main menu.

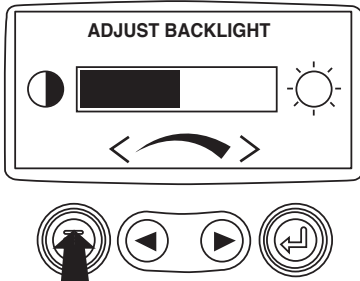

6. Press the "Menu Button" to exit the Main menu and return to the engine parameter display.

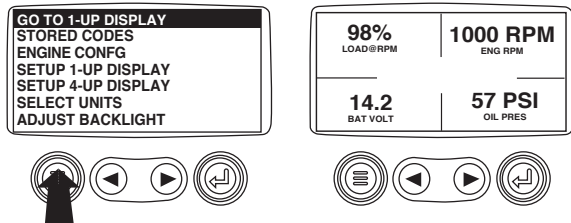

POWerview OPERATION *continued*

Contrast Adjustment

1. Starting at the single or four engine parameter display depress the "Menu Button".

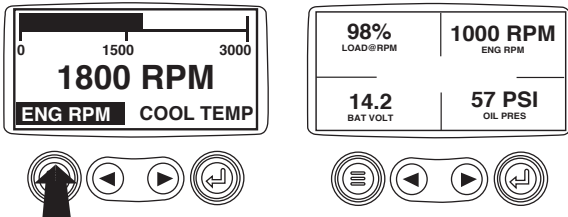

2. The main menu will pop up on the display. Use the "Arrow Buttons" to scroll through the menu until "Adjust Contrast" is highlighted.

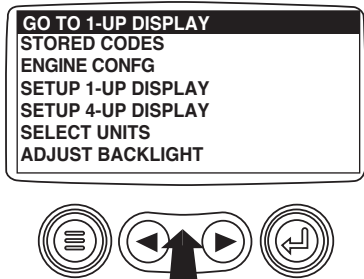

3. Once the "Adjust Contrast" menu item has been highlighted press the "Enter Button" to activate the "Adjust Contrast" function.

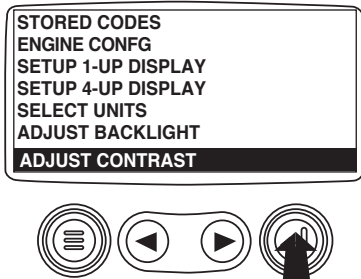

4. Use the "Arrow Buttons" to select the desired contrast intensity.

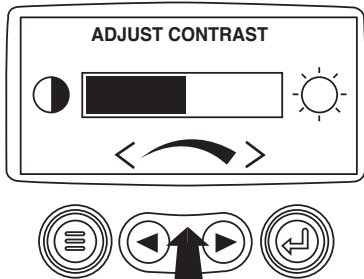

5. Press the "Menu Button" to return to the main menu.

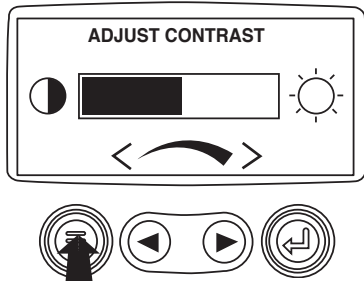

6. Press the "Menu Button" to exit the Main menu and return to the engine parameter display.

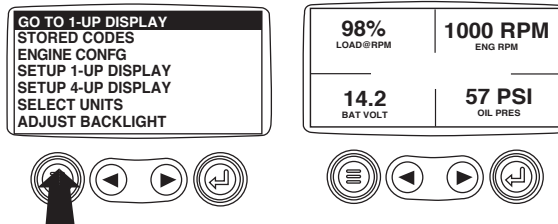

Select Units

1. Starting at the single or four engine parameter display depress the "Menu Button".

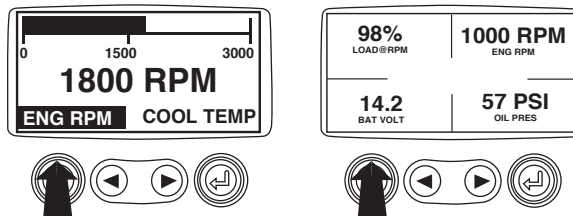

2. The main menu will pop up on the display. Use the arrow buttons to scroll through the menu until the "Select Units" is highlighted.

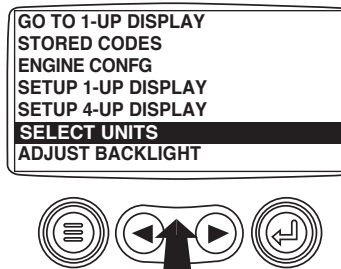

3. Once the "Select Units" menu item has been highlighted press the "Enter Button" to access the "Select Units" function.

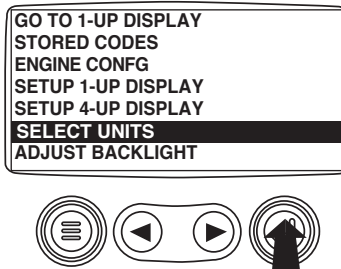

4. Use the arrows to highlight the desired units. "English" for Imperial units i.e. PSI, °F or Metric kPa, Metric Bar for IS units i.e. kPa, Bar, °C.

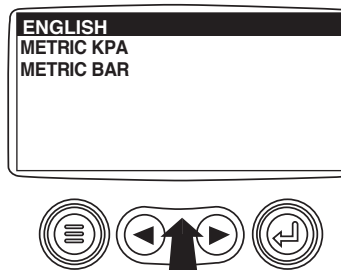

POWerview OPERATION *continued*

5. Press the "Enter Button" to select the highlighted units.

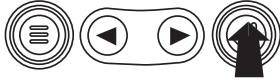
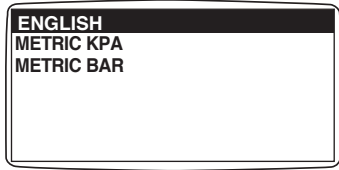

6. Press the "Menu Button" to return to the "Main Menu".

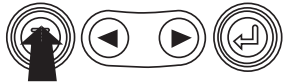
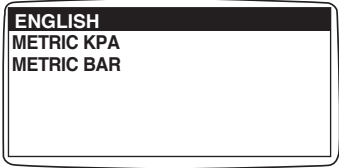

7. Press the "Menu Button" to exit the Main menu and return to the engine parameter display.

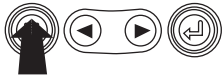
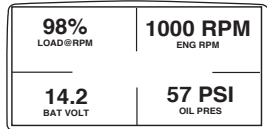
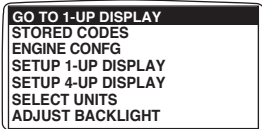

Setup 1-Up Display

1. Starting at the single engine parameter display press the "Menu Button".

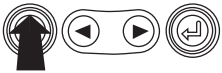
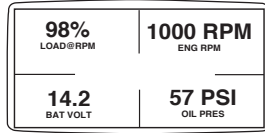
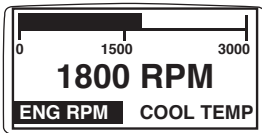

2. The main menu will pop up on the display. Use the "Arrow Buttons" to scroll through the menu until the "Setup 1-up Display" is highlighted.

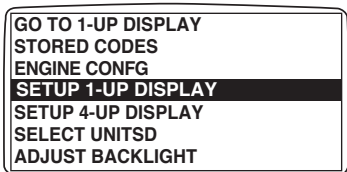

3. Once the "Setup 1-up Display" menu item has been highlighted press the "Enter Button" to access the "Setup 1-up Display" function.

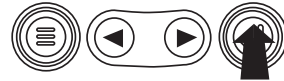
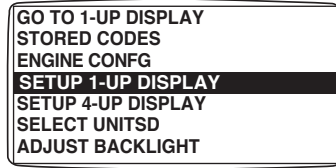

4. Three options are available for modification of the 1-Up display.

- a). **Use Defaults** – This option contains a set of engine parameters: Engine Hours, Engine RPM, System Voltage, Battery Voltage, % Engine Load at Current RPM, Coolant Temperature, Oil Pressure.
- b). **Custom Setup** – This option allows for the modification of what parameter, the number of parameters, and the order in which the parameters are being displayed.
- c). **Automatic Scan** – Selecting the scan function will cause the 1-Up Display to scroll through the selected set of parameters one at a time, momentarily pausing at each.

5. **Use Defaults** – To select "Use Defaults" use the arrow buttons to scroll to and highlight "Use Defaults" in the menu display.

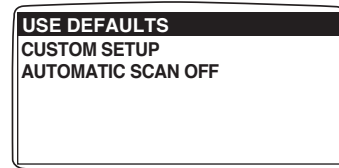

6. Press the "Enter Button" to activate the "Use Defaults" function.

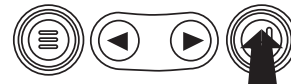
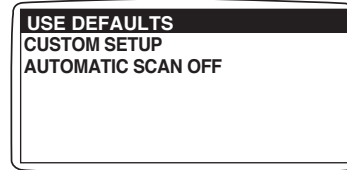

7. A message indicating the "Single Engine" parameter display parameters are reset to the factory defaults will be displayed, then the display will return to the "Custom Setup" menu.

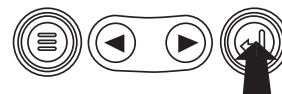

POWerview OPERATION *continued*

8. Custom Setup - To perform a custom setup of the 1-Up Display use the arrow buttons to scroll to and highlight "Custom Setup" on the display.

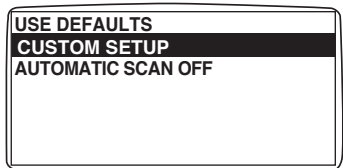

9. Pressing the "Enter Button" will display a list of engine parameters.

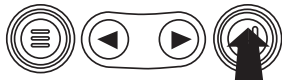
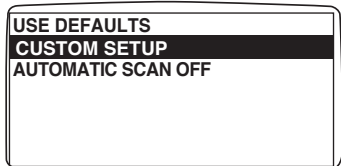

10. Use the "Arrow Buttons" to scroll to and highlight a selected parameter (parameter with a # symbol to right of it).

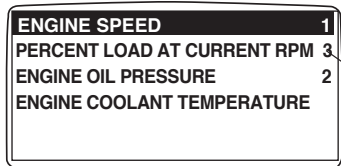

This number indicates the order of display for the parameters and that the parameter is selected for display.



11. Press the "Enter Button" to deselect the selected parameter removing it from the list of parameters being displayed on the 1-up display.

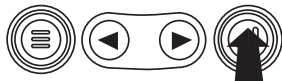
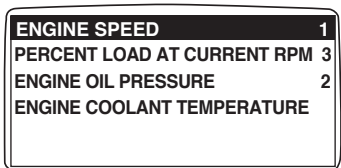

12. Use the "Arrow Buttons" to scroll and highlight the desired parameter that has not been selected for display.

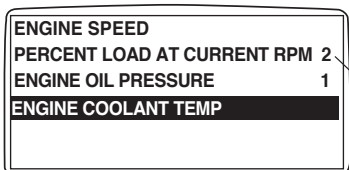

Note that the numbers now indicate the new order of display for the parameters.



13. Press the "Enter button" to select the highlighted parameter for inclusion in the Single Engine Parameter Display.

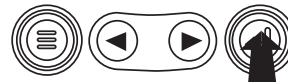
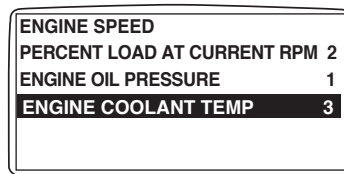

14. Continue to scroll and select additional parameters for the custom 1-Up Display. Press the "Menu button" at any time to return to the "Custom Setup" menu.

15. Automatic Scan - Selecting the scan function will cause the 1-Up Display to scroll through the selected set of parameters one at a time. Use the "Arrow Buttons" to scroll to the "Automatic Scan" function.

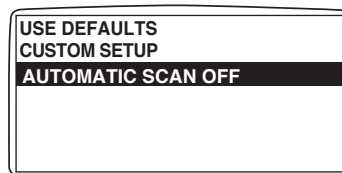

16. Pressing the "Enter Button" toggles the "Automatic Scan" function on.

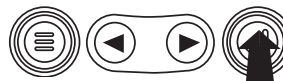
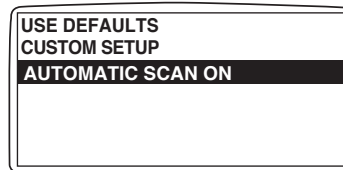

17. Pressing the "Enter Button" again toggles the "Automatic Scan" function off.

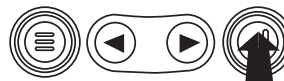
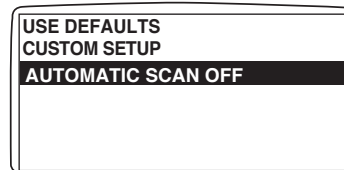

POWerview OPERATION *continued*

18. Once the "Use Defaults", "Custom Setup" and "Automatic Scan" functions have been set press the "Menu Button" to return to the main menu.

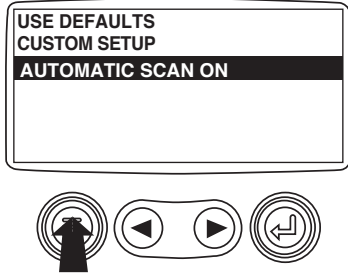

19. Press the "Menu Button" to exit the Main menu and return to the engine parameter display.

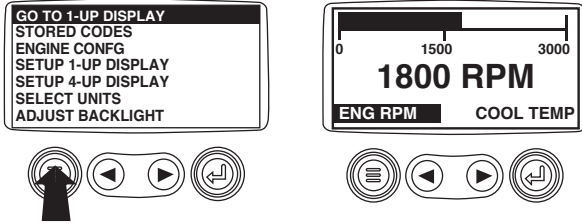

Setup 4-Up Display

1. From the single or four engine parameter display press the "Menu Button".

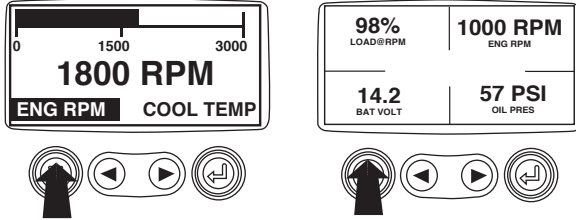

2. The main menu will pop up on the display. Use the "Arrow Buttons" to scroll through the menu until the "Setup 4-Up Display" is highlighted.

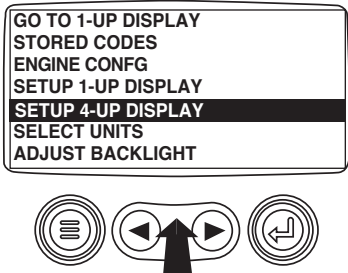

3. Once the "Setup 4-Up Display" menu item has been highlighted press the "Enter Button" to activate the "Setup 4-Up Display" menu.

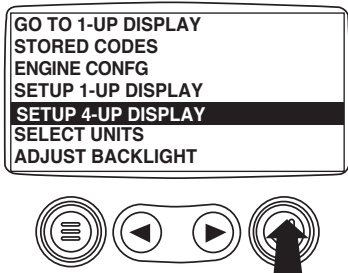

4. Press the "Enter Button" to activate the "Use Defaults" function. This action will reset the unit to the factory default.

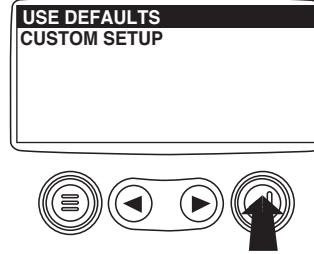

5. The "Use Defaults" screen will be displayed during the resetting period then will automatically return to the "Setup 4-Up Display" menu.

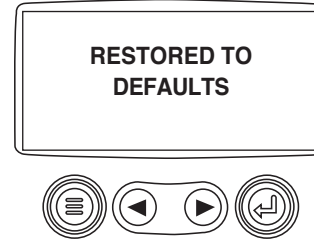

6. Select the "4-Up Custom Setup" from the "4-Up Setup" menu.

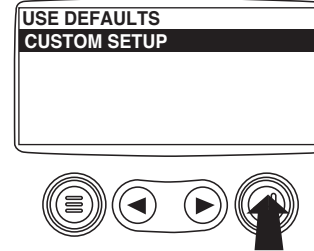

7. The quadrant with the backlit parameter value is the current selected parameter. Use the "Arrow Buttons" to highlight the parameter value in the quadrant you wish to place a new parameter.

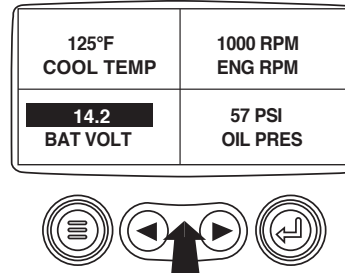

8. Press the "Enter Button" and a list of parameters will appear.

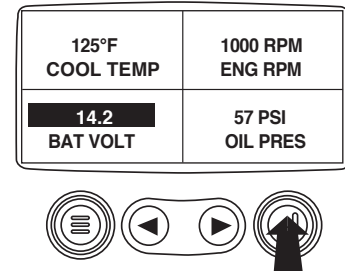

POWerview OPERATION *continued*

9. The parameter that is highlighted is the selected parameter for the screen. Use the "Arrow Buttons" to highlight the new parameter to be placed in the quadrant selected in the previous screen.

ENGINE SPEED	3
ENGINE HOURS	
ENGINE COOLANT TEMPERATURE	1
BATTERY POTENTIAL	
ENGINE OIL TEMPERATURE	2
ENGINE OIL PRESSURE	4

The number to the right of the parameter indicates the quadrant in which it is displayed.
 1. = Upper Left Quadrant
 2. = Lower Left Quadrant
 3. = Upper Right Quadrant
 4. = Lower Right Quadrant



10. Press the "Enter Button" to change the selected parameter in the quadrant to the new parameter.

ENGINE SPEED	3
ENGINE HOURS	
ENGINE COOLANT TEMPERATURE	1
BATTERY POTENTIAL	
ENGINE OIL TEMPERATURE	2
ENGINE OIL PRESSURE	4

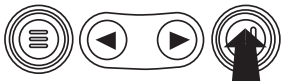

11. Use the "Menu Button" to return to the "4-UP Custom Setup" screen.

ENGINE SPEED	3
ENGINE HOURS	
ENGINE COOLANT TEMPERATURE	1
BATTERY POTENTIAL	
ENGINE OIL TEMPERATURE	2
ENGINE OIL PRESSURE	4

Note the number to the right of the selected parameter indicating that the parameter is now assigned to that display location.

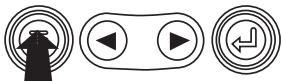

12. The parameter in the selected quadrant has changed to the parameter selected in the previous screen.

125°F	1000 RPM
COOL TEMP	ENG RPM
143°F	57 PSI
OIL TEMP	OIL PRES



13. Repeat the parameter selection process until all spaces are filled.

14. Press the "Menu Button" to return to the main menu.

125°F	1000 RPM
COOL TEMP	ENG RPM
143°F	57 PSI
OIL TEMP	OIL PRES

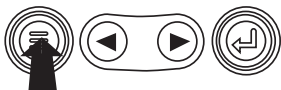

15. Press the "Menu Button" to exit the Main menu and return to the engine parameter display.

GO TO 1-UP DISPLAY	
STORED CODES	
ENGINE CONFG	
SETUP 1-UP DISPLAY	
SETUP 4-UP DISPLAY	
SELECT UNITS	
ADJUST BACKLIGHT	

125%	1000 RPM
COOL TEMP	ENG RPM
143°F	57 PSI
OIL TEMP	OIL PRES

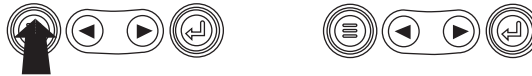

Utilities (Information and troubleshooting)

1. Starting at the single or four engine parameter display, press the "Menu button."

0	1500	3000
1800 RPM		
ENG RPM	COOL TEMP	

125%	1000 RPM
COOL TEMP	ENG RPM
143°F	57 PSI
OIL TEMP	OIL PRES



2. The main menu will be displayed. Use the "Arrow buttons" to scroll through the menu until the "Utilities" is highlighted.

STORED CODES
ENGINE CONFG
SETUP 1-UP DISPLAY
SETUP 4-UP DISPLAY
SELECT UNITS
ADJUST BACKLIGHT
UTILITIES



3. Once the "Utilities" menu item has been highlighted, press the "Enter Button" to activate the "Utilities" functions.

STORED CODES
ENGINE CONFG
SETUP 1-UP DISPLAY
SETUP 4-UP DISPLAY
SELECT UNITS
ADJUST BACKLIGHT
UTILITIES



4. Press "Select" to enter the "Gages Data" display. When "Gage Data" is selected the PowerView will communicate with the analog gages at a fixed rate of 38.4 k Baud, 8 data bits, no parity check, 1 stop bits, half duplex.

GAGE DATA
REMOVE ALL GAGES
SOFTWARE VERSION
FAULT CONVERSION

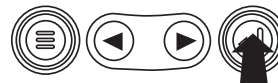

POWerview OPERATION *continued*

5. Use the “Arrow buttons” to scroll through the items or press “Menu” to return to the “Utilities” menu.

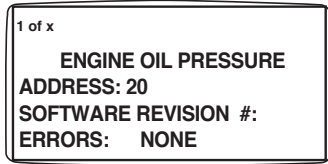

6. Press “Menu Button” to return to the “Utilities” menu.

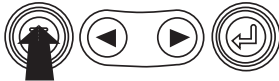
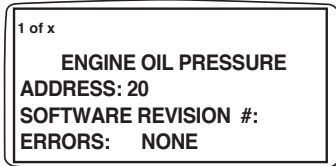

7. Use the “Arrows” to highlight “Remove All Gages”. Press “Select” to clear gage data from memory. It takes a moment to clear all gages.

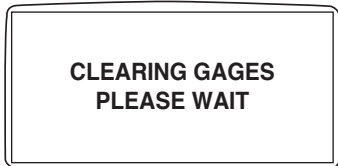

8. When the gage data has cleared, the display automatically returns to the “Utilities” menu. Scroll to “Software Version”. Press “Select” to view the software version currently in the PowerView.

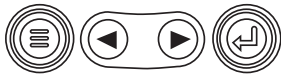
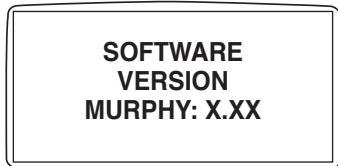

9. Press “Menu” to return to “Utilities”. Highlight “Fault Conversion” using the “Arrows”. Press “Select” to enter the Fault conversion menu.

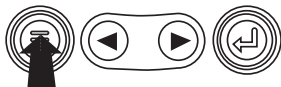
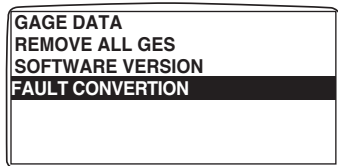

11. Using the “Arrow” buttons scroll to highlight the version to be selected. Press the “Select” button to select the version. Note that an asterisks appears to the right of the selection.

NOTE: There are four (4) different methods for converting fault codes. The PowerView always looks for J1939 Version 4 and can be set to use one of the three (3) other J1939 versions. Most engine ECU’s use Version 4, therefore in most cases adjustment of this menu option will not be required.

Upon receiving an unrecognizable fault, change to a different J1939 Version. If the fault SPN does not change when the version is changed, the ECU generating the fault is using Fault Conversion method 4. If the SPN number does change but is still unrecognizable, try changing to another J1939 Version not yet used and continue to check the SPN number.

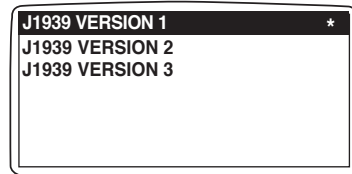

12. Press the “Menu” button to return to “Utilities” menu. Press the “Menu” button again to return to the “Main” menu.

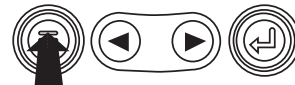
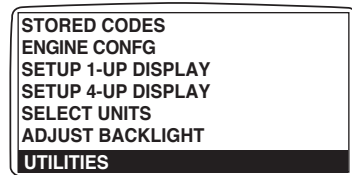

2.9 WIRING DIAGRAM

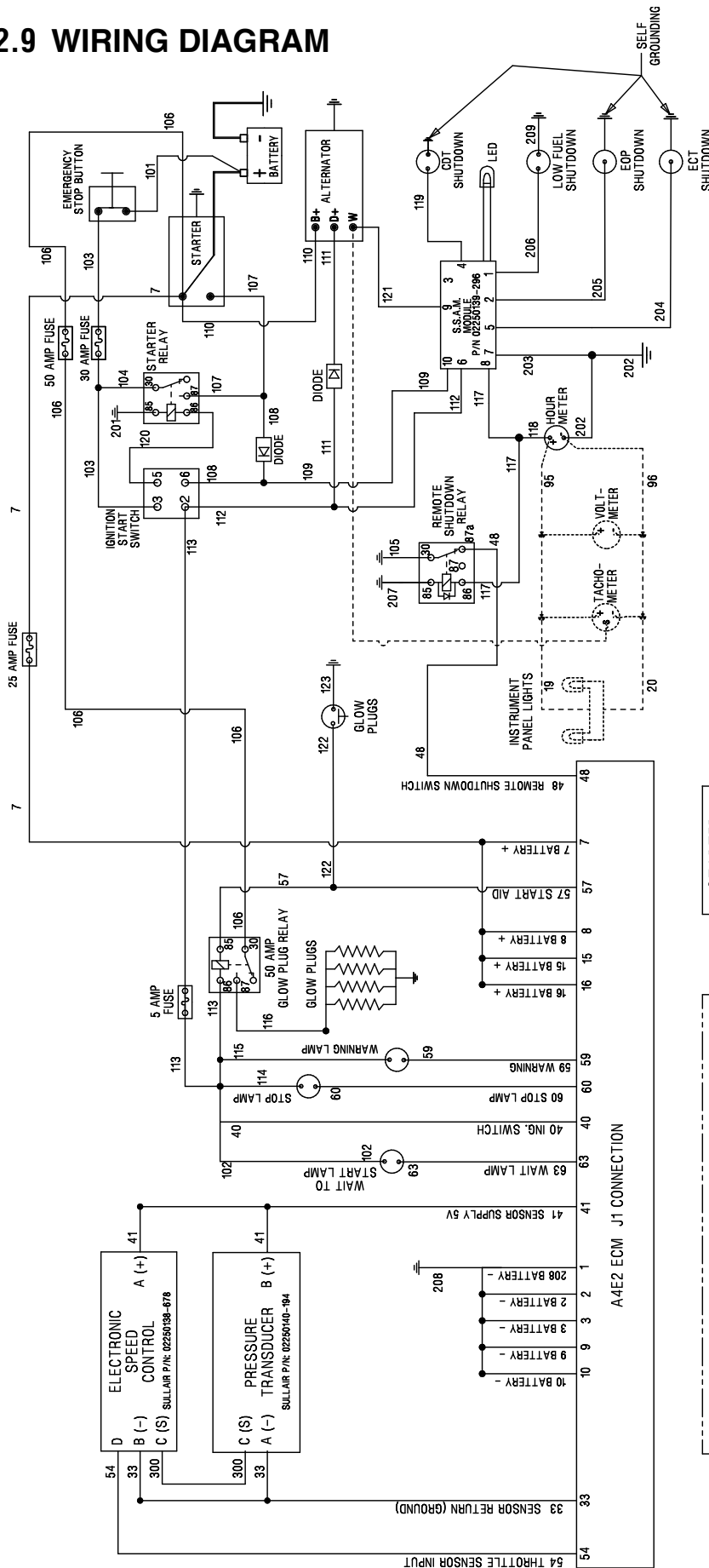

NOTE: GROUND WIRES 201, 202, 207, 208 AND 209 ARE DIRECT TO BATTERY NEGATIVE.

REF: SULLAIR DECAL P/N 02250165-171
SULLAIR WIRING HARNESS P/N 02250165-172

02250165-168_R06

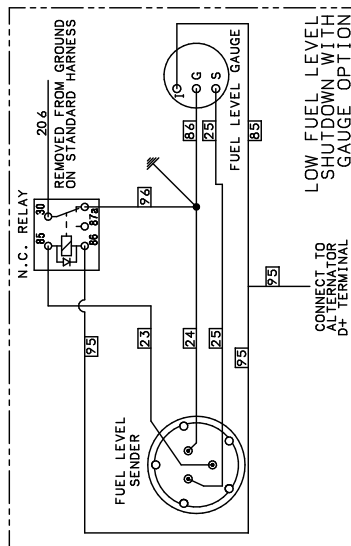
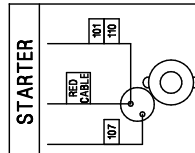

2.10 ELECTRICAL SYSTEM, FUNCTIONAL DESCRIPTION

The electrical system consists of the basic electrical elements required to operate the compressor and also has a system feature that automatically shuts down the compressor when a malfunction occurs. The system's components include: an engine starter, battery, alternator/voltage regulator, and a fuel solenoid. It also has a compressor discharge temperature switch that will shut the compressor down if the compressor temperature exceeds 250° F (121° C). It has an engine water temperature switch set to shut down the compressor when the coolant temperature reaches 234° F (112° C) and an oil pressure switch that will shut down the compressor if the engine oil pressure goes too low. An underspeed sensor shuts down the compressor if the engine speed falls below 1500 rpm and a low fuel level switch shuts down the engine when fuel level is low to prevent running the engine dry (out of fuel). The engine is also equipped with an ECM (electronic control module).

2.11 COMPRESSOR SHUTDOWN & WARNING SYSTEM, FUNCTIONAL DESCRIPTION

The Shutdown System and Annunciator Module (SSAM) continuously monitors the status of the compressor. In the event of a shutdown condition, the SSAM will shut down the compressor and display (flashing) the appropriate code on the instrument panel annunciator light. The display will continue flashing until the ignition switch is turned OFF. The shutdown codes are:

- One flash: high compressor discharge temperature
- Two flashes: high engine coolant temperature
- Three flashes: low engine oil pressure
- Four flashes: low engine speed
- Five flashes: low fuel level

The SSAM also provides startup logic for the compressor. When the ignition switch is in the ON position, the annunciator light will illuminate for 30 seconds. During this 30 second period, pressing the ignition switch will engage the engine starter. The low engine speed switch is inactive during this startup time interval. By the end of these 30 seconds, the annunciator light goes out and the engine START cycle is disabled. At this time the system runs all safety checks including low fuel level.

The engine is equipped with an electronic speed control and has a shutdown protection/diagnostic capability. A variety of sensors and a speed control module interface with the ECM. These sensors include the following: oil pressure, coolant temperature, intake manifold, fuel temperature, timing cranking; and a remote shutdown switch. The engine speed control module consists of the module and a pressure transducer. The pressure transducer senses the compressor control pressure and as the control pressure increases, the speed control module decreases the engine speed by lowering the output voltage to the ECM.

2.12 AFTERCOOLED AND FILTERED AIR SYSTEM, FUNCTIONAL DESCRIPTION

Refer to *Figure 2-3*. The purpose of the aftercooled system is to operate the air compressor in conditions when compressed air temperature is required to be within 20° to 25°F (13° to 17°C) of the ambient temperature.

A selector valve is provided on all aftercooled compressors. Choosing the aftercooled air completely forces the airflow from the receiver tank to the aftercooler. The ambient air which is drawn through the aftercooler by the engine fan, cools the compressed air as it passes through the aftercooler core. Cooled air enters the moisture separator where condensation is removed from the cooler air and discharged. **This condensate does carry some oil and it should be disposed of properly in accordance with local regulations.**

From the moisture separator the air enters the (optional) first stage filter. Particles and additional water are removed

from the first stage filter. **The condensate should be drained and stored in a suitable container.** From the first stage filter, the air enters the (optional) second stage filter. This filter removes smaller particles and any additional water. **The condensate should be drained and stored in a suitable container.** Upon compressor shutdown, the filters will drain to clear the condensate from the system. This will prevent freezing in cold conditions.

NOTE

The aftercooler system should not be operated when the ambient temperature is below 32°F (0°C). To operate in the non-aftercooled mode close the aftercooler selector valve completely.

2.13 LISTING OF DIAGNOSTIC CODES

NOTE

In some cases there are differences between J1939SPN and CDL codes (those normally viewed on the service tool).

Trouble Codes

Type	CID/EID	J1939SPN	FMI	Lamp Flash Code (future)	Component	Description
Diagnostic	91	91	2	154	Throttle Position Sensor	Data Erratic, Intermittent, or Incorrect
Diagnostic	91	91	3	154	Throttle Position Sensor	Voltage Above Normal or Shorted High
Diagnostic	774	91	3	155	Secondary Throttle Position Sensor	Voltage Above Normal or Shorted High
Diagnostic	91	91	4	154	Throttle Position Sensor	Voltage Below Normal or Shorted Low
Diagnostic	774	91	4	155	Secondary Throttle Position Sensor	Voltage Below Normal or Shorted Low
Diagnostic	91	91	8	154	Throttle Position Sensor	Abnormal Frequency, Pulse Width, or Period
Diagnostic	774	91	8	155	Secondary Throttle Position Sensor	Abnormal Frequency, Pulse Width, or Period
Diagnostic	91	91	12	154	Throttle Position Sensor	Bad Device or Component
Diagnostic	774	91	12	155	Secondary Throttle Position Sensor	Bad Device or Component
Diagnostic	100	100	3	157	Engine Oil Pressure Sensor	Voltage Above Normal or Shorted High
Diagnostic	100	100	4	157	Engine Oil Pressure Sensor	Voltage Below Normal or Shorted Low
Diagnostic	100	100	10	157	Engine Oil Pressure Sensor	Engine Oil Pressure Sensor 5V Supply Connection Circuit Open
Event	360	100	17	n/a	Engine Oil Pressure Sensor	Low Oil Pressure - WARNING
Event	360	100	18	n/a	Engine Oil Pressure Sensor	Low Oil Pressure - DERATE
Event	360	100	1	n/a	Engine Oil Pressure Sensor	Low Oil Pressure - SHUTDOWN
Event	539	105	15	n/a	Inlet Manifold Air Temp Sensor	High Intake Manifold Pressure - WARNING
Event	539	105	16	n/a	Inlet Manifold Air Temp Sensor	High Intake Manifold Pressure - DERATE
Diagnostic	172	105	3	133	Inlet Manifold Air Temp Sensor	Voltage Above Normal or Shorted High
Diagnostic	172	105	4	133	Inlet Manifold Air Temp Sensor	Voltage Below Normal or Shorted Low
Diagnostic	1785	106	3	135	Inlet Manifold Pressure Sensor	Voltage Above Normal or Shorted High
Diagnostic	1785	106	4	135	Inlet Manifold Pressure Sensor	Voltage Below Normal or Shorted Low
Diagnostic	1785	106	10	135	Inlet Manifold Pressure Sensor	Inlet Manifold Pressure Sensor 5V Connection Circuit Open
Event	361	110	15	n/a	Engine Coolant Temp Sensor	High Coolant Temp - WARNING
Event	361	100	16	n/a	Engine Coolant Temp Sensor	High Coolant Temp - DERATE
Diagnostic	110	100	3	169	Engine Coolant Temp Sensor	Voltage Above Normal or Shorted High

Type	CID/EID	J1939SPN	FMI	Lamp Flash Code (future)	Component	Description
Event	361	110	0	n/a	Engine Coolant Temp Sensor	High Coolant Temp - SHUTDOWN
Diagnostic	110	110	4	169	Engine Coolant Temp Sensor	Voltage Below Normal or Shorted Low
Diagnostic	1797	157	3	n/a	Fuel Rail Pressure Sensor	Voltage Above Normal or Shorted Low
Diagnostic	1797	157	4	n/a	Fuel Rail Pressure Sensor	Voltage Below Normal or Shorted Low
Diagnostic	1834	158	2	439	Keyswitch	Data Erratic, Intermittent, or Incorrect
Diagnostic	168	168	0	422	ECM Battery Power	Excessive Battery Power
Diagnostic	168	168	1	422	ECM Battery Power	Low Battery Power
Diagnostic	168	168	2	422	ECM Battery Power	Intermittent
Diagnostic	190	190	8	141	Speed/Timing Sensor	Abnormal Signal Frequency
Event	362	190	15	n/a	Engine Speed	Engine Overspeed - WARNING
Diagnostic	91	588	2	154	Throttle Position Switch	Idle Validation Switch
Diagnostic	774	558	2	155	Secondary Throttle Position Switch	Data Erratic, Intermittent, or Abnormal
Diagnostic	268	630	2	527	Customer or System Parameters	Data Incorrect
Diagnostic	253	631	2	415	Engine Software	Data Incorrect
Diagnostic	247	639	9	514	SAE J1939 Data Link	Abnormal Update
Diagnostic	526	646	5	177	Turbo Wastegate	Solenoid Current Low
Diagnostic	526	646	6	177	Turbo Wastegate	Solenoid Current High
Diagnostic	526	646	7	177	Turbo Wastegate	Turbo Wastegate Not Responding
Diagnostic	1	651	5	n/a	Cylinder #1 Injector	Injector Current Low
Diagnostic	1	651	6	n/a	Cylinder #1 Injector	Injector Current High
Diagnostic	1	651	7	n/a	Cylinder #1 Injector	Injector Not Responding
Diagnostic	2	652	5	n/a	Cylinder #2 Injector	Injector Current Low
Diagnostic	2	652	6	n/a	Cylinder #2 Injector	Injector Current High
Diagnostic	2	652	7	n/a	Cylinder #2 Injector	Injector Not Responding
Diagnostic	3	653	5	n/a	Cylinder #3 Injector	Injector Current Low
Diagnostic	3	653	6	n/a	Cylinder #3 Injector	Injector Current High
Diagnostic	3	653	7	n/a	Cylinder #3 Injector	Injector Not Responding
Diagnostic	4	654	5	n/a	Cylinder #4 Injector	Injector Current Low
Diagnostic	4	654	6	n/a	Cylinder #4 Injector	Injector Current High
Diagnostic	4	654	7	n/a	Cylinder #4 Injector	Injector Not Responding
Diagnostic	5	655	5	n/a	Cylinder #5 Injector	Injector Current Low
Diagnostic	5	655	6	n/a	Cylinder #5 Injector	Injector Current High
Diagnostic	5	655	7	n/a	Cylinder #5 Injector	Injector Not Responding
Diagnostic	6	656	5	n/a	Cylinder #6 Injector	Injector Current Low
Diagnostic	6	656	6	n/a	Cylinder #6 Injector	Injector Current High
Diagnostic	6	656	7	n/a	Cylinder #6 Injector	Injector Not Responding
Diagnostic	41	678	3	517	8V DC Supply	ECM 8V DC Supply - Voltage Above Normal or Shorted High

SECTION 2

Type	CID/EID	J1939SPN	FMI	Lamp Flash Code (future)	Component	Description
Diagnostic	41	678	4	517	8V DC Supply	ECM 8V DC Supply - Voltage Below Normal or Shorted Low
Diagnostic	342	723	8	142	Secondary Engine Speed Sensor	Abnormal Signal Frequency
Diagnostic	262	1079	3	516	5V DC Supply Sensor	Voltage Above Normal or Shorted High
Diagnostic	262	1079	4	516	5V DC Supply Sensor	Voltage Below Normal or Shorted Low
Diagnostic	261	637	11	143	Primary to Secondary Speed Sig.	Calibration Fault
Diagnostic	1779	1347	5	162	Fuel Rail Pump	Output Current Low
Diagnostic	1779	1347	6	162	Fuel Rail Pump	Output Current High
Diagnostic	1779	1347	7	162	Fuel Rail Pump	Not Responding
Diagnostic	2246	676	5	199	Glow Plug Start Aid Relay	Current Low
Diagnostic	2246	676	6	199	Glow Plug Start Aid Relay	Current High

2.14 OPERATION OF THE INDICATOR LAMPS

Warning Lamp (Alert Lamp)	Stop Lamp (Action Lamp)	Lamp State	Description of the Indication	Engine State
On	On	Lamp Check	When the engine switch is moved to the ON position, the lamps come on for a period of 2 seconds and the lamp will then go off.	The engine switch is in the ON position but the engine has not yet been cranked.
Off	Off	No Faults	With the engine in operation, there are no active warnings, diagnostic codes or event codes	The engine is operating with no detected faults.
On	Off	Active Diagnostic	If the warning lamp comes on during engine operation, this indicates that an active diagnostic code (an electrical fault) is present.	The engine is operating normally but there is one or more faults with the electronic management system for the engine.
On	Flashing	Derate (A derate is caused by certain active codes.)	If the warning lamp comes on and the stop lamp flashes during engine operation, this indicates that an active diagnostic code (an electrical fault) is present. The diagnostic is sufficiently serious in order to cause an engine derate.	The engine is operating but there is one or more active diagnostic codes that have initiated an engine derate.
Flashing	Off	Warning (Warning only)	When the warning lamp flashes during operation of the engine, the lamp indicates that one or more of the warning values for the engine protection strategy has been exceeded. However, the value has not been exceeded to a level that will cause a derate or a shutdown.	The engine is operating normally. However, there is one or more of the monitored engine parameters that are outside of the range that is acceptable.
Flashing	Flashing	Derate (Warning and Derate)	If both the warning lamp and stop lamp flash during operation of the engine, the lamps indicate that one or more of the values for the engine protection strategy have been exceeded beyond the level that will cause an engine derate.	The engine is operating. However, one or more of the monitored engine parameters is outside of the acceptable range. The acceptable range has been exceeded to a level which requires a warning and an engine derate.
On	On	Engine Shutdown	If both the warning lamp and the stop lamp come on during engine operation, this indicates one of the following conditions. <ol style="list-style-type: none"> One or more of the shutdown values for the engine protection strategy has been exceeded. A serious active diagnostic code has been detected. After a short period of time, the engine will shut down.	The engine is either shutdown or an engine shutdown is imminent. One or more monitored engine parameters have exceeded the limit for an engine shutdown. This pattern of lamps can be caused by the detection of a serious active diagnostic code.

2.15 FLASH CODES

The “Flash Code” feature is used to flash the code of all active diagnostic codes and logged diagnostic codes. The sequence for the flash code is started by moving the engine switch to “Off” and then move the engine switch to “On” twice within a period of three seconds. After a delay of 2 seconds, the “Stop” lamp will flash once for a period of half a second. This sequence indicates the start of the active fault codes. After a further delay of 2 seconds, the “Warning” lamp will flash repeatedly in order to indicate the active diagnostic codes. Each flash will be on for half a second and off for 300 milliseconds. The “Warning” lamp will remain off for 2 seconds between each digit of a code. If there is more than one active diagnostic code, the “Stop” lamp will go off for 2 seconds. The lamp will then come on for a period of half a second. The “Warning” lamp will go off for a period of 2 seconds before starting the next code. If there are no active diagnostic codes, the “Warning” lamp will flash the code “551”. Refer to Troubleshooting Guide, “No Diagnostic Code Detected”. As an example, an active diagnostic code of “21” is indicated by the “Warning” lamp coming on for 500ms, then off for 300 ms, the on for 500 ms, then off for 2000 ms, then on for 500 ms and then off. After all the active diagnostic codes have been displayed, the “Stop” lamp will go off for 2 seconds. The “Stop” lamp will flash twice in order to indicate the start of the sequence that will display the logged diagnostic codes. The process for flashing logged diagnostic codes is identical to the process for flashing active diagnostic codes.

After all of the codes have been displayed, the “Stop” lamp will flash 3 times in order to indicate that there are no further codes. Cycling the engine switch twice within a period of 3 seconds will start the process again. All codes will be displayed in ascending numerical order.

Refer to the listing of “Diagnostic Codes” for the diagnostic code that relates to the flash code.

NOTE

Flash codes are always sent in ascending numerical order.

NOTE

If there are no logged codes then the “551” code should be flashed again.

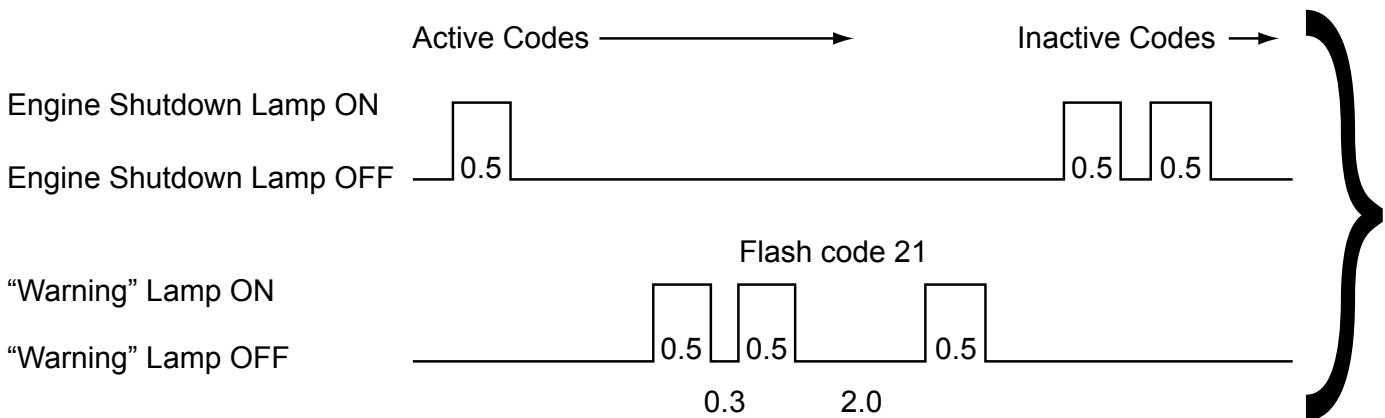

Note: Times shown in seconds



Section 3

SPECIFICATIONS

3.1 SPECIFICATIONS – 300HH AND 375 CATERPILLAR

DIMENSIONS								
Model Series	Length (l)		Width		Height		Weight (wet)	
	in	mm	in	mm	in	mm	lb	kg
300HH, and 375 2-Wheel	156.2	3967.5	77.2	1960.9	74.0	1879.6	4420*	2004.9*
300HH, and 375 Less Running Gear	98.8	2509.5	59.3	1506.2	63.6	1615.4	4175*	1893.8*

(l) Length over drawbar for 2 – wheel version
***Add 115 lbs (52 kg) for Aftercooled Version**

COMPRESSOR	300HH	375
Type	Rotary Screw	Rotary Screw
Maximum Operating Pressure	200 psig (13.8 bar)	125 psig (8.6 bar)
Pressure Delivery	300 Free CFM (142 L/S)	375 Free CFM (177 L/S)
Rated Pressure	200 psig (13.8 bar)	100 psig (6.9 bar)
Cooling	Pressurized Compressor Fluid	Pressurized Compressor Fluid
Lubricating Compressor Fluid	See Table 1	See Table 1
Sump Capacity	7 US gallons (26.5 liters)	7 US gallons (26.5 liters)
Track Width	67.5" (1714.5 mm)	67.5" (1714.5 mm)
Tire Size (Load Range)	H78 x 15ST (D)	H78 x 15ST (D)
Tire Pressure	65 psig (4.4 bar)	65 psig (4.4 bar)
Wheel Size	15 x 6JJ	15 x 6JJ
Lug Nut Torque	60 ft-lbs (81 Nm)	60 ft-lbs (81 Nm)
Operating Tilt (maximum)	15°	15°
Electrical System	12 volt	12 volt
Compressor Discharge Temperature	Shutdown 250°F (121°C)	Shutdown 250°F (121°C)
Service Valves	(2) ¾"	(2) ¾"
Maximum Towing Speed	55 mph (88 kmph)	55 mph (88 kmph)
Axle Rating	5000 lbs (2268 kg)	5000 lbs (2268 kg)
Sound Level	76 dBA at 7 m	76 dBA at 7 m

SECTION 3

ENGINE:	300HH	375
Type	Diesel	Diesel
Make	Caterpillar	Caterpillar
Model	C4.4	C4.4
Displacement	268 cu/in (4.4L)	268 cu/in (4.4L)
Cylinders	4	4
Bore x Stroke	4.13 x 5.00 (105 mm x 127 mm)	4.13 x 5.00 (105 mm x 127 mm)
Rated Speed	2200 rpm	2200 rpm
Rated Power	130HP/97kW	117HP/87kW
Type of Motor Oil	See Engine Operator Manual	See Engine Operator Manual
Fuel Tank Capacity	56 gallons (212 liters)	56 gallons (212 liters)
Radiator Capacity	4 gallons (15 liters)	4 gallons (15 liters)
Engine Water Temperature	Shutdown 234°F (112°C)	Shutdown 234°F (112°C)
Minimum Idle Speed	1600 rpm (II)	1600 rpm (II)
Alternator Rating	65 amp	65 amp
<p>(II) DO NOT allow engine idle rpm to drop below minimum idle speed. Compressor and/or coupling damage will occur. The compressor is equipped with a Low Speed Shutdown System that will shutdown the compressor if engine speed falls below 1500 rpm.</p>		

3.2 SPECIFICATIONS – 375H AND 425 CATERPILLAR

DIMENSIONS								
Model Series	Length (I)		Width		Height		Weight (wet)	
	in	mm	in	mm	in	mm	lb	kg
375H and 425 2-Wheel	156.2	3967.5	77.2	1960.9	74.0	1879.6	4420*	2004.9*
375H and 425 Less Running Gear	98.8	2509.5	59.3	1506.2	63.6	1615.4	4175*	1893.8*
<p>(I) Length over drawbar for 2 – wheel version *Add 115 lbs (52 kg) for Aftercooled Version</p>								

COMPRESSOR	375H	425
Type	Rotary Screw	Rotary Screw
Maximum Operating Pressure	150 psig (10 bar)	125 psig (8.6 bar)
Delivery	375 Free CFM (177 L/S)	425 Free CFM (201 L/S)
Rated Pressure	150 psig (10.3 bar)	100 psig (6.9 bar)
Cooling	Pressurized Compressor Fluid	Pressurized Compressor Fluid
Lubricating Compressor Fluid	See Table 1	See Table 1
Sump Capacity	7 US gallons (26.5 liters)	7 US gallons (26.5 liters)
Track Width	67.5" (1714.5 mm)	67.5" (1714.5 mm)
Tire Size (Load Range)	H78 x 15ST (D)	H78 x 15ST (D)
Tire Pressure	65 psig (4.4 bar)	65 psig (4.4 bar)
Wheel Size	15 x 6JJ	15 x 6JJ
Lug Nut Torque	60 ft-lbs (81 Nm)	60 ft-lbs (81 Nm)
Operating Tilt (maximum)	15°	15°

Electrical System	12 volt	12 volt
Compressor Discharge Temp	Shutdown 250°F (121°C)	Shutdown 250°F (121°C)
Service Valves	(2) ¾"	(2) ¾"
Maximum Towing Speed	55 mph (88 kmph)	55 mph (88 kmph)
Axle Rating	5000 lbs (2268 kg)	5000 lbs (2268 kg)
Sound Level	76 dBA at 7 m	76 dBA at 7 m

ENGINE:	375H	425
Type	Diesel	Diesel
Make	Caterpillar	Caterpillar
Model	C4.4	C4.4
Displacement	268 cu/in (4.4L)	268 cu/in (4.4L)
Cylinders	4	4
Bore x Stroke	4.13 x 5.00 (105 mm x 127 mm)	4.13 x 5.00 (105 mm x 127 mm)
Rated Speed	2200 rpm	2200 rpm
Rated Power	130HP/97kW	130HP/97kW
Type of Motor Oil	See Engine Operator Manual	See Engine Operator Manual
Fuel Tank Capacity	56 gallons (212 liters)	56 gallons (212 liters)
Radiator Capacity	4 gallons (15 liters)	4 gallons (15 liters)
Engine Water Temperature	Shutdown 234°F (112°C)	Shutdown 234°F (112°C)
Minimum Idle Speed	1600 rpm (II)	1600 rpm (II)
Alternator Rating	65 amp	65 amp

(II) DO NOT allow engine idle rpm to drop below minimum idle speed. Compressor and/or coupling damage will occur. The compressor is equipped with a Low Speed Shutdown System that will shutdown the compressor if engine speed falls below 1500 rpm.

3.3 LUBRICATION GUIDE – COMPRESSOR

FLUID TYPE	CHANGE PERIOD/HOURS	AMBIENT TEMPERATURE RANGE °F (°C)
Sullair AWF (I)	1500	-20 to 120 (-29 to 49)
SAE 10W SE, SF, SG, CD	250	0 to 100 (-18 to 38)
MIL-L-2104E 10W	250	0 to 100 (-18 to 38)

(I) Sullair part numbers for Sullair AWF are 250030-757 (5 gallons/18.9 liters) and 250030-758 (55 gallon drum/208 liters).

3.4 APPLICATION GUIDE

Sullair air compressors are supplied with Sullair AWF which is a heavy duty multi-viscosity, all weather fluid which provides an extended change interval when compared to other fluids. Detergent motor oils (SAE 10W Class SE, SF, SG, or CD) can also be used. Any of these oils are suitable under conditions where severe oil oxidation can occur.

Water must be drained from the receiver tank periodically. In high ambient temperature and humidity conditions, condensed moisture can emulsify with the oil forming a “milky” color. SAE 10W is especially prone to this condition. The fluid should be changed if this condition develops. DO NOT mix different fluids. Combinations of different fluids can lead to operational problems such as foaming, plugged filters, blocked orifices or lines.

When ambient conditions exceed the recommended ranges, or if other conditions warrant the use of other extended life lubricants, contact your local Sullair representative for recommendations.

Sullair encourages users to participate in a fluid analysis program. The analysis might indicate a need for change intervals different from those recommended in this manual. Sullair Corporation offers a fluid analysis for Sullair AWF. Contact Sullair for details.

D-A Lubricant® Company Inc. offers an analysis for users of Sullair AWF. Contact your Sullair representative for details.

3.5 LUBRICATION GUIDE – ENGINE

Refer to the **Engine Operator’s Manual** for oil specifications.

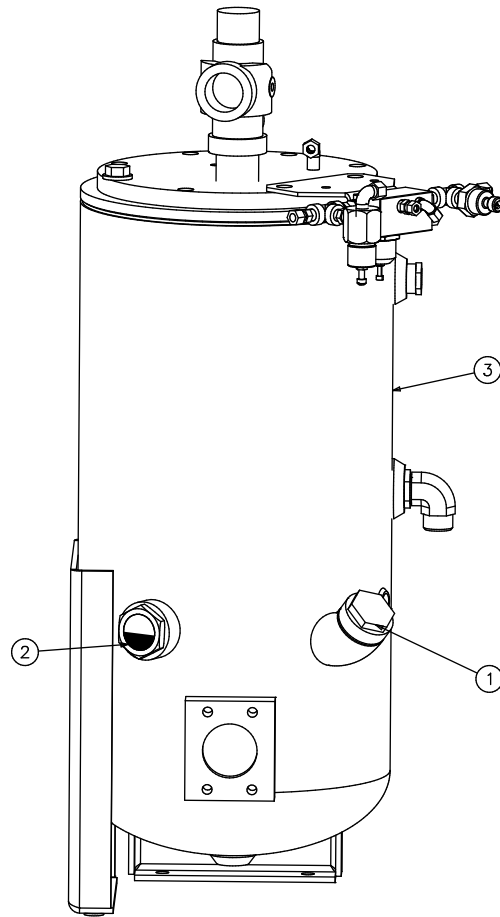

SU_0000699

1. Fluid Fill Port
2. Sight Glass
3. Sump Tank

Figure 3-1

NOTE

Proper Compressor Fluid Level
Visible halfway in fluid sight glass
when checked on a level surface with
the compressor not running.

Section 4

GENERAL

4.1 GENERAL

While Sullair has built into this compressor a complete set of controls and indicators that allow the operator to control and monitor the compressor's operation and performance. Operators should learn to recognize indications which identify a service requirement or conditions that could lead to (or show) a (current) malfunction. Before starting the compressor, read this section thoroughly to gain familiarity with the controls and indicators – their function and location.

4.2 PURPOSE OF CONTROLS

Control or Indicator Purpose

Engine Switch

Press this switch to the ON (ignition) position to energize the electrical system of the compressor. Press the switch to the START position to momentarily engage the starter and start the compressor. Press the switch to the OFF position to shut the compressor down. This switch is located on the instrument panel.

Emergency Stop Switch

Press in case of emergency when immediate shutdown is required.

Pressure Transducer

Monitors the system control pressure.

Speed Module

Monitors the pressure transducer output and determines the appropriate speed signal for the engine.

Air Pressure Gauge

Continuously monitors the pressure inside the receiver sump at various load and unload conditions.

Fluid Sight Level Glass

Indicates the fluid level in the sump. Proper level is marked halfway up the sight glass. Check the level when the compressor is shutdown and on level ground.

Compressor Discharge Temperature Switch

Opens the electrical circuit to shut down the compressor when the discharge temperature reaches a specific value (*See Specifications on page 53 and on page 55*).

Thermal Valve

Functions as a temperature regulator by directing the compressor fluid either to the cooler or to the compressor unit.

Minimum Pressure Device

Maintains the minimum of 80 psig (5.6 bar) in the compressor sump.

Pressure Relief Valve

Vents sump pressure to the atmosphere if pressure inside the sump exceeds 250 psig (17.3 bar).

Air Inlet Valve

Regulates the amount of air allowed to enter the air compressor inlet. Regulation is determined by a signal from the pressure regulator(s).

Pressure Regulator(s)

Allows the pressure signal to reach the engine speed transducer and the air inlet valve to control air delivery according to demand.

Discharge Air Filter Differential Pressure Gauge (Optional Aftercooled and Filtered Models Only)

Monitors the air filter (first and second stage) condition. A reading over 10 psig (0.7 bar) in the red zone indicates the air filters require servicing.

Shutdown System/Annunciator Module (SSAM)

SECTION 4

Monitors the compressor safety system for conditions requiring shutdown. The annunciator on the instrument control will flash the applicable shutdown code.

Blowdown Valve

Vents sump pressure to the atmosphere at shutdown.

Idle Warm-Up Control

Keeps the compressor inlet valve closed for reduced compressor load at start-up. When the compressor is warmed-up, the handle is turned from the START to the RUN position for full operation.

Pressure Selector Switch (H and HH Models)

Sets compressor operation in the LOW range from 80 to 110 psig (5.6 to 7.6 bar), or in the HIGH range from 80 to 165 psig (5.6 to 11.4 bar) on H models, and from 80 to 220 psig (5.6 to 15.2 bar) on HH models.

4.3 INITIAL STARTUP/SHUTDOWN PROCEDURE

Startup

Perform the following actions when starting the compressor for the first time:

1. Ensure that the compressor is on a level surface. (If the compressor is on an uneven surface, the fluid sight gauge readings will not be accurate, and it will not be possible to determine if fluid levels are too low.) (I)
2. Check the oil and fluid levels in the engine and compressor: add oil and/or fluid if necessary.
3. Fill the fuel tank and drain any water from the fuel/water separator.
4. Crack open one service line.
5. Place the WARM-UP control in the START position.
6. Place the PRESSURE SELECTOR switch to the LOW position (H and HH models).
7. Press the ENGINE SWITCH to the ON position.
8. When glow plugs are required, when the engine start switch is pressed on the ON position, the amber "Wait to Start" warning lamp will light. Leave the engine switch in the ON position until the warning light for the glow plugs is extinguished.
9. Momentarily press the ENGINE SWITCH to the START position to engage the starter: release the switch when the engine starts.
10. After 30 seconds (the annunciator light will go off after 30 seconds) Turn the IDLE WARM-UP SWITCH from START to RUN to put the compressor in full operation.
11. Close all doors to maintain proper noise level.

(I) The radiator is filled with a 50/50 mixture of ethylene glycol and water. All engines receive Supplemental Coolant Additive (SCA) at the factory before shipment. Refer to the **Engine Operator's Manual** for specific requirements.

Shutdown

1. Close the service valves and run the compressor for approximately five minutes to allow the compressor to cool down.
2. Place the pressure selector switch in the low position (H and HH models).
3. Press the ENGINE SWITCH to the OFF position after five minutes. When an emergency shutdown is required, IMMEDIATELY press the EMERGENCY SHUTDOWN BUTTON.

4.4 RESTART PROCEDURE

After running and shutting down the compressor for the first time, perform the following actions when restarting the compressor:

1. Check engine oil, engine coolant, and fuel levels.
2. Check the compressor fluid level (sight glass) and drain any water from the fuel/water separator.
3. Check the dust collectors and clean if necessary.
4. Crack open the service valve.
5. Place the WARM-UP control in the START position.
6. Place the PRESSURE SELECTOR switch to the LOW position (H and HH models).
7. Press the ENGINE SWITCH to the ON position.
8. When glow plugs are required, when the engine start switch is pressed on the ON position, the amber "Wait to Start" warning lamp will light. Leave the engine switch in the ON position until the warning light for the glow plugs is extinguished.
9. Momentarily press the ENGINE SWITCH to the START position to engage the starter: release the switch when the engine starts.
10. After 30 seconds (the annunciator light will go off after 30 seconds) Turn the IDLE WARM-UP SWITCH from START to RUN to put the compressor in full operation.
11. Close all doors to maintain proper noise level.
12. To shut down the compressor, see *Shutdown on page 58*.

WARNING

DO NOT use aerosol types of starting aids such as ether.

Such use could result in an explosion and personal injury.

If the engine fails to start within 30 seconds, release the starter switch or button and wait two minutes to allow the starting motor to cool before attempting to start the engine again.

Section 5

MAINTENANCE

WARNING

DO NOT remove caps. Plugs and/or other components when the compressor is running or pressurized. Shutdown the compressor before removing any components.

5.1 GENERAL

Consistent and correctly performed maintenance will ensure the compressor's performance and extend its operational life. See *Part Replacement and Adjustment Procedures on page 61* for a detailed description of specific compressor components. Before performing maintenance actions, read the CIMA Safety Manual, if applicable. For engine maintenance requirements and procedures, refer to the **Engine Operator's Manual**.

5.2 DAILY MAINTENANCE

See *Initial Startup Shutdown/Procedure on page 58* for general operation.

NOTE

The radiator and engine cooling system must be drained and flushed every 1500 hours. Replace the solution coolant with a 50% ethylene glycol and 50% water solution or as required for local climatic conditions. **DO NOT** use a leak-sealing type antifreeze. All engines must have Supplemental Coolant Additive (SCA) added to the engine coolant system. Refer to the **Engine Operator's Manual** for specific requirements.

If fluid must be added too frequently at startup, a problem might have developed causing an excessive fluid loss. See *Trouble Shooting on page 68 (Excessive Fluid Consumption)* for a probable cause and remedy. After the compressor has warmed-up, make a general inspection of its components and instrument panel to ensure that the compressor is running properly.

NOTE

Dispose of fluids in accordance with applicable federal, state and local regulations.

5.3 MAINTENANCE AFTER INITIAL 50 HOURS OF OPERATION

After the initial 50 hours of operation, the following maintenance actions are required to eliminate contaminants from the system:

1. Clean the return line orifice and change the strainer.
2. Change the compressor fluid filter.
3. Check the **Engine Operator's Manual** for service requirements.
4. Check the fuel filter for water.
5. Confirm that the sump cover bolts are tightened to 160 lb-ft (215N•m).

5.4 MAINTENANCE EVERY 50 HOURS

1. Inspect air filter elements and replace if necessary.
2. Check the fuel filter for water.

5.5 MAINTENANCE EVERY 100 HOURS

After 100 hours of operation:

1. Clean the radiator and cooler exterior surfaces.
2. Check the **Engine Operator's Manual** for service requirements.

5.6 MAINTENANCE EVERY 250 HOURS

After 250 hours of operation:

1. Check fan belt tension.
2. Clean the radiator and cooler exterior surfaces. (Where dust and other atmospheric contaminants are present, it might be necessary to clean these parts more frequently.)
3. Check the **Engine Operator's Manual** for service requirements.
4. Change the engine oil and filter.

NOTE

The fluid change period varies by fluid brand, Refer to the *Lubrication Guide – Compressor on page 56*.

5. Change the compressor fluid if it is not Sullair AWF:
 - a. Run the compressor for five to ten minutes to warm the fluid
 - b. Shut the compressor down and relieve all internal pressure
 - c. Drain the fluid sump by removing the plug, or opening the valve at the bottom of the sump tank
 - d. Remove any dirt from the fluid filter cap before filling the sump
 - e. Fill the sump with fluid in accordance with the specifications in *Specifications on page 53 and on page 54*.
6. Clean or replace the return line strainer.
7. Change the air filter primary elements.
8. Change the compressor fluid filter.
9. Clean the return line orifice.
10. Change the fuel filter. (If the filter tends to clog more often than what is expected, change the filter more frequently.)
11. Change the engine fuel/water separator.
12. Check the engine rpm idle speed. The idle speed should be at the specified minimum idle speed listed in *Specifications on page 53 and on page 55*.

⚠ WARNING

Operating the compressor at below its minimum specified idle speed will damage the compressor. Operating the compressor in this condition will cause coupling and/or compressor failure.

5.7 MAINTENANCE EVERY 1500 HOURS

1. If the compressor fluid is Sullair AWF, change the fluid and replace the fluid filter element. (*See Compressor Fluid Filter Element Replacement on page 61*).
2. Service the engine cooling system.
3. Lubricate axle bearings on wheel-mounted units.

5.8 PART REPLACEMENT AND ADJUSTMENT PROCEDURES

Compressor Fluid Change Procedure

1. Run the compressor five to ten minutes to warm the fluid.
2. Shut the compressor down and relieve all internal pressure.
3. Drain the fluid sump by removing the plug, or opening the valve at the bottom of the sump tank.
4. Change the compressor fluid and replace the fluid filter element (For element replacement see the filter servicing procedure in this Section.)
5. Fill the sump with fluid in accordance with the specifications in *Specifications on page 53 and on page 54.*

Compressor Fluid Filter Element Replacement

Refer to *Figure 5-1.*

1. Remove the old element with a strap wrench.
2. Clean the gasket seating surface.
3. Apply a light coating of fluid to the new gasket.
4. Hand tighten the new element (P/N 250025-525) until the new gasket is seated.
5. Continue tightening the element by hand an additional 1/2 to 3/4 turn.
6. Restart the compressor and check for leaks.

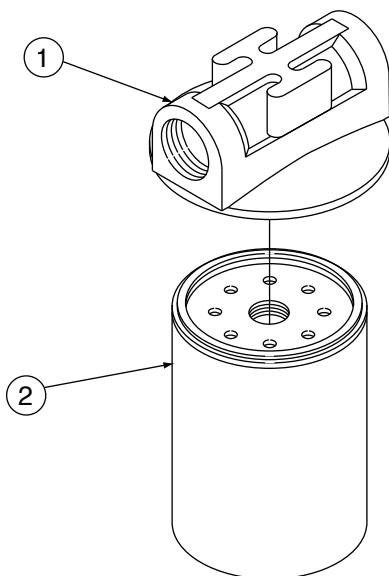

SU_0000669

1. Filter Head
2. Fluid Filter

Figure 5-1

Air Filter Maintenance

Refer to *Figure 5-2.* Air filter maintenance should be performed as often as conditions require. If the filters are equipped with optional maintenance indicators, change the filters every time the indicators show a change is necessary.

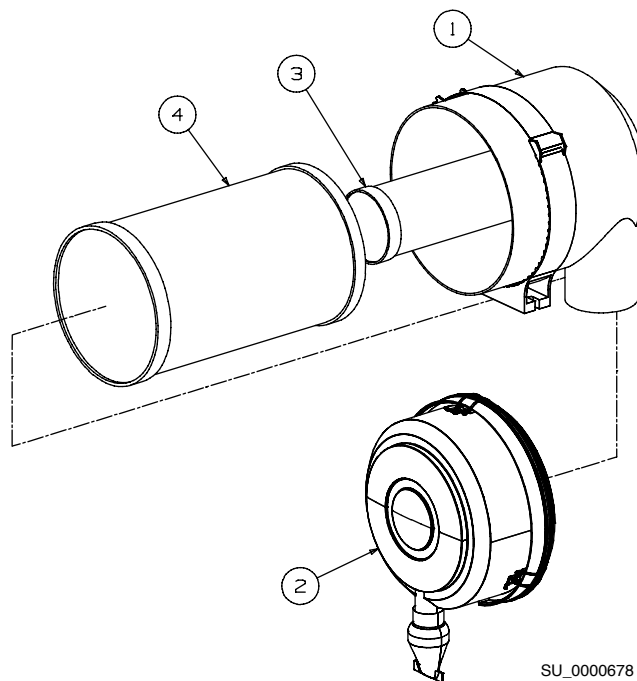

SU_0000678

1. Filter Body
2. Filter Cover
3. Safety (Secondary) Element**
4. Primary Element*

*Replacement Primary Element
P/N 02250164-532

**Replacement Safety (Secondary) Element
P/N 02250164-533

Figure 5-2

Air Filter Replacement

1. Loosen and remove the air filter and cover.
2. Remove the primary and secondary elements.
3. Clean the body, inside and out, with a damp cloth.
4. Reinstall (if clean) or replace the secondary element.
5. Replace the new primary filter element.
6. Reposition the cover and lock it into the position.
7. Reset the filter restriction indicator (if equipped).

Element Inspection

1. Insert a bright light source into the element and look for any light leaks which indicate the presence of damage (holes, cracks, etc.)
2. Inspect all gaskets and gasket contact surfaces of the housing and replace any damaged ones.
3. Store clean elements for later use in a clean container.
4. After installing the element, inspect and tighten all air inlet connections before operating the compressor.

Separator Element Replacement

Refer to *Figure 5-3*. When compressor fluid carryover is evident, after replacing or inspecting the fluid return line strainer and orifice, and the blowdown valve; and all are in satisfactory condition, the separator element must be replaced with Kit number 250034-087 (element for air/fluid separator).

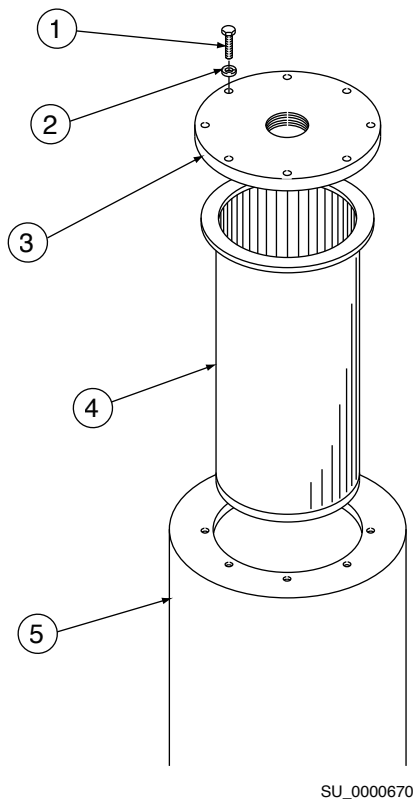

1. Capscrew
2. Washer
3. Cover
4. Separator Element with Gaskets
5. Receiver Tank

Figure 5-3: Air/Fluid Separator

1. Disconnect all sump cover piping connections to permit removal (return line, service line, etc.).
2. Remove the fluid return line from the fitting on the cover.

3. Remove the eight (8) cover bolts and washers and lift the cover off the sump.
4. Remove the separator element.
5. Scrape the old gasket material from the cover and the flange on the sump. Do not allow the scrapings to fall into the tank.
6. Install the new element.
7. Replace the sump cover and bolts. Lightly tighten all the bolts and then gradually tighten them alternating between bolts which are diagonally opposite each other. Torque the bolts to 160 ft-lbs (215 N•m).
8. Reconnect all piping. The fluid return line tube should extend to the bottom of the separator element which will ensure proper return line flow.
9. Clean the fluid return line strainer and clear the orifice before starting the compressor.
10. After 24 hours of operation, tighten the sump cover bolts to the value given in step 7.

Procedure For Setting Speed And Pressure Controls On Portable Compressors Equipped With Poppet Valves

Refer to *Figure 5-4* and *Figure 5-5*. Before adjusting the compressor's control system, the rated full-load pressure and the high/low rpm settings must be determined. This information is provided in *Specifications on page 54* and *on page 55* or can be obtained by contacting a Sullair representative.

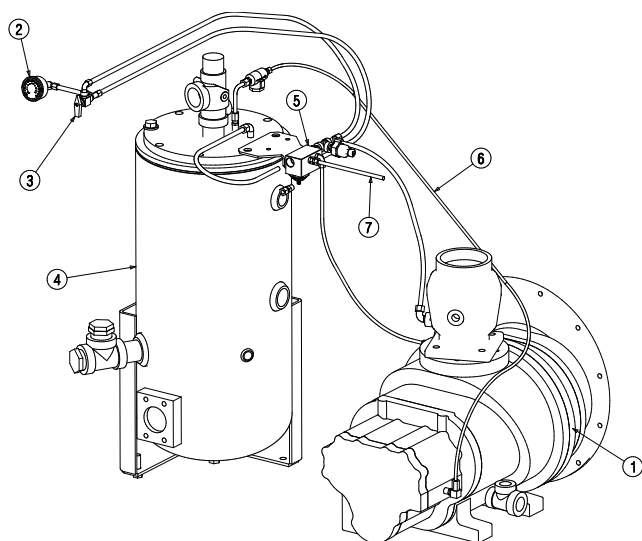

fig_5-4a-hi-press-t3-r01

1. Compressor Unit
2. Air Pressure Gauge
3. Warm-Up Control Valve
4. Receiver/Sump Tank
5. Pressure Regulator/Blowdown Manifold
6. Oil Return Line
7. Blowdown Line (To Fitting At Filter Hose)

Figure 5-4: Control System Adjustment – Standard Pressure

The following procedure applies to a compressor with full-load pressure rating of 100 psig (6.9 bar).

1. Remove the speed control module (mounted on lifting bail) mounting screws and lift the module away from the mounting surface. Turn the module over to expose the engine speed adjustment buttons.
2. Start the compressor and allow the engine to warm-up to its normal operating temperature with the service valve closed.
3. With service valve closed, set the engine low speed (idle) to its specified setting with the LO (+) or LO (-) buttons on the speed control module. Holding the LO (+) button will increase the idle speed; holding the LO (-) button will decrease the idle speed setting.

WARNING

Operating the compressor at below its minimum specified idle speed will damage the compressor. Operating the compressor in this condition will cause coupling and/or compressor failure.

4. Adjust the pressure regulator setting to maintain 115 psig (8 bar) receiver tank pressure.
5. Gradually open the service valve to atmosphere until the engine speed increases and the receiver tank pressure stabilizes at 100 psig (6.9 bar). Adjust the engine high idle speed to its specified setting with the HI (+) or HI (-) buttons on the speed control module. Holding the HI (+) button will increase the high idle speed; holding the HI (-) button will decrease the high idle speed setting.
6. Open the service valve to 100 psig (6.9) (rated full-load pressure) and recheck maximum engine speed and control response. Close the service valve and allow the compressor to cycle and recheck the low engine idle speed.
7. To reset the speed control module to the default values, press the LO (+) and LO (-) buttons at the same time.

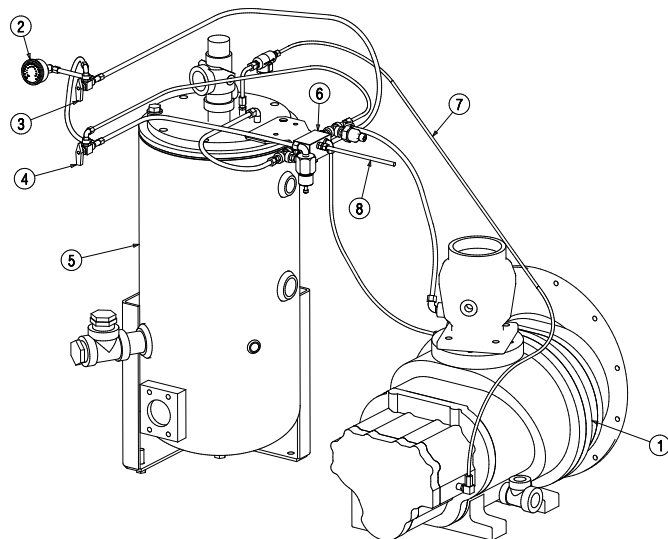

fig_5-4std-press-t3-r01

1. Compressor Unit
2. Air Pressure Gauge
3. Warm-Up Control Valve
4. High/Low Pressure Valve
5. Receiver/Sump Tank
6. Pressure Regulator/Blowdown Manifold
7. Oil Return Line
8. Blowdown Line (To Fitting At Filter Hose)

Figure 5-5: Control System Adjustment – Dual Pressure

SECTION 5

The following steps apply to “H” and “HH” compressors equipped with dual pressure controls.

1. Start the compressor and allow the engine to warm up to its normal operating temperature with the service valve closed and the pressure selector valve set to the LOW position.
2. Follow the procedure for setting the controls to 100 psig (6.9 bar) rated full load pressure as describe in preceding steps 2 through 6.
3. Turn the pressure selector valve to the HIGH position with the service valve closed.
4. Adjust the high pressure regulator so that the compressor maintains a receiver tank pressure of 165 psig (11.4 bar) on “H” models or 220 psig (15.2 bar) on “HH” models.
5. Gradually open the service valve to atmosphere until the engine speed increases and the receiver tank pressure stabilizes at 150 psig (10.3 bar) on “H” models or 200 psig on “HH” models. At this point the engine should be operating at its rated speed. If necessary use the HI (+) or HI (-) buttons on the speed control module to set the specified idle speed.

Bearing Lubrication

Refer to *Figure 5-6*. Proper lubrication of the portable compressor’s bearing axle is critical to its proper function and reduction of wear on this part. Wheel bearings should be lubricated at least every 12 months, or more, to ensure proper performance and minimize wear. Use a wheel bearing grease that conforms to MILSPEC MIL-G-10924 or a high temperature one such as lithium complex NLGI consistency #2.

Axles with the E-Z Lube feature can be periodically lubricated without removing the hubs from the axle. This feature consists of axle spindles that have been fitted with a grease zerk in their ends. When grease is pumped into the zerk, it is channeled to the inner bearing and then flows back to the outer bearing, and then back out of the grease cap hold (*see Figure 5-6*).

1. Remove the rubber cap from the grease cap’s end.
2. Using a full charged grease gun, place the gun onto the grease zerk located on the end of the spindle. Make sure the nozzle is fully engaged on the fitting.
3. Pump grease into the zerk. The old grease will be displaced and flow out of the cap around the grease gun nozzle.
4. When the new grease starts flowing out of the cap, disengage the gun and wipe off any excess off the cap; and replace the rubber plug.

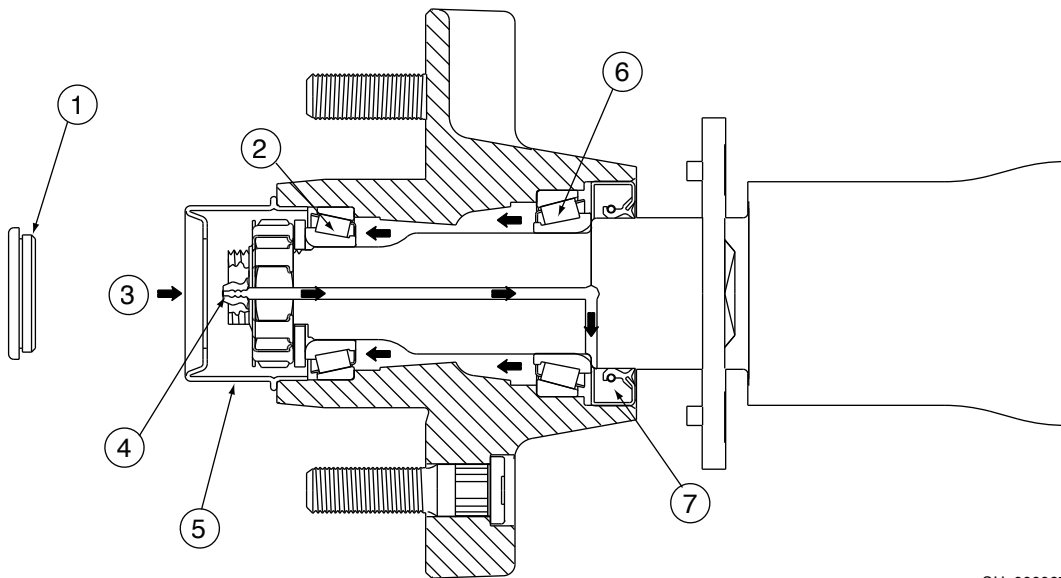

SU_0000671

1. Rubber Plug
2. Outer Bearing
3. Grease Flow
4. Grease Fitting

5. Metal End Cap
6. Inner Bearing
7. Spring Loaded Double Lip Seal

Figure 5-6: Typical E-Z Lube Axle

First and Second Stage Discharge Air Filter Maintenance – Aftercooled & Filtered Models

General

Refer to *Figure 5-7*. Familiarity with the filtration process and the unit's monitoring system (consisting of a complete set of gauges) will enable the operator to locate and analyze malfunctions.

The first and second stage filter element should be changed when the pressure drop reaches the red band on the pressure differential gauge.

Daily Operation

Check the automatic drain trap daily to ensure it is operating properly.

First and Second Stage Element Replacement

1. Depressurize the filter and remove the filter housing.
2. Remove the element.
3. Clean the inside of the filter housing, if necessary.
4. Install a new element and gaskets (P/N 02250153-294 FIRST STAGE) (P/N 02250153-305 SECOND STAGE)
5. Reassemble the unit and check for air leaks.
6. Record the initial pressure drop when the compressor is started.

Safety

Toxic And Irritating Substances

 WARNING
<p>Death or serious injuries can result from inhaling compressed air without using proper safety equipment. (See applicable OSHA Standards)</p>

DO NOT use air from this filter as a source for respiration (breathing air) except when in compliance with OSHA STANDARDS 29 CFR 1910, and all other applicable Federal, state, or local codes or regulations.

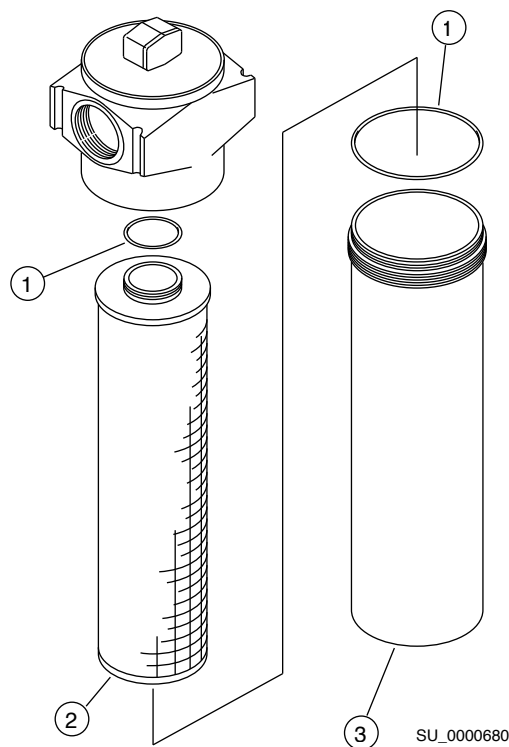

1. O-Ring
2. Filter Element
3. Filter Housing

Figure 5-7: First and Second Stage Discharge Air Filter (Optional)

These filters will not remove water vapor, oil vapor, carbon monoxide, or other toxic gases.

The first stage filter efficiently removes contaminants such as ash, dust, water aerosols, lubricant mist, carbon particles, rust and other contaminants (0.3 microns and larger).

The second stage filter removes particulates and all lubricant aerosols of 0.01 micron size and larger.

Design Ratings

Design ratings are 150°F (66°C) maximum air inlet temperature. All welded filter housings are ASME code stamped for 250 psig (17.3 bar) maximum working pressure.

5.9 TROUBLE SHOOTING

The following Trouble Shooting chart is based upon data obtained from factory tests and information from the field. It lists symptoms, probable causes and remedies. This chart does not cover all possible malfunctions or cases of abnormal operation. Before undertaking repairs or replacement actions, analyze all of the available data.

Performing a detailed visual inspection in all cases can prevent additional damage or abnormal operation.

Always:

1. Check for loose wiring or connections.
2. Check for damaged piping.
3. Check for heat damage to parts (electrical short circuits can cause heat damage) which can appear as discolorations or the presence of a burnt odor.

If the troubleshooting remedy does not work, or the malfunction is not covered in this Trouble Shooting chart, contact your nearest Sullair representative or Sullair for technical assistance.

ENGINE DOES NOT CRANK OR CRANKS BUT DOES NOT START		
SYMPTOM	PROBABLE CAUSE	REMEDY
NO SSAM FLASH CODE	Low voltage or battery disconnected	Check battery cables and tighten if loose
		Check ground wire for proper attachment to frame. Tighten if required.
		Recharge or replace battery if required.
	Blown fuse in wiring harness	Remove and inspect fuse. Replace if necessary.
	Instrument panel connectors loose or disconnected.	Check instrument panel connectors and reattach if required
Check instrument panel wires for broken connections or corrosion. Clean and/or replace if damaged.		
	Faulty SSAM module	Replace the module
SSAM FLASH CODE: ONE FLASH	Compressor temperature switch is open	Check wiring connection to the switch and tighten if loose
		Check switch continuity to ground and replace if necessary
		If the compressor feels hot see COMPRESSOR OVERHEATING trouble shooting procedure
SSAM FLASH CODE: TWO FLASHES	Engine coolant temperature switch is open	Check wiring connection to the switch and tighten if necessary
		Check switch continuity to ground and replace if necessary
	Cooling air flow is insufficient	Clean cooler and check for proper ventilation
	Loose or broken fan belt	Check fan belt and tighten or replace if necessary
	Engine problems might be present	Refer to the Engine Operator's Manual
	No engine coolant	Fill with proper water/glycol mixture as required
SSAM FLASH CODE:THREE FLASHES	Engine oil pressure switch is open	Check wiring connection to switch and tighten if necessary
		Install gauge in parallel with the switch. Replace the switch if the pressure exceeds 15 psig and stays open. If the pressure is less than 15 psig, refer to the Engine Operator's Manual .

ENGINE DOES NOT CRANK OR CRANKS BUT DOES NOT START

SYMPTOM	PROBABLE CAUSE	REMEDY
SSAM FLASH CODE:FOUR FLASHES	Did not start compressor within the 30 seconds from turning the ignition switch to the ON position	After turning the ignition switch to the ON position, press the switch to the START position within 30 seconds
	Low battery voltage	Check the battery cables and tighten if necessary
		Recharge or replace battery if necessary
	No fuel	Refuel
	Water or dirt in the fuel and/or filter	Drain water from the fuel/water separators on the fuel filters. Siphon water from the fuel tank and clean the tank if necessary
	Plugged air filter	Clean and replace if necessary
	Plugged fuel filter	Replace the fuel filter
	Engine problems	Turn the compressor OFF. Use the PowerView menu to determine the engine fault. Ignore the SSAM Flash Code. See the Engine Warning/Shutdown Table for probable causes
	Starter solenoid relay does not engage	Check wiring and tighten all connectors Replace relay
No input frequency from alternator	Check alternator "W" terminal (7.5 ± 2.50 VAC greater than 300 HZ)	
SSAM FLASH CODE: FIVE FLASHES	No fuel	Check fuel level and fill tank if empty
	Defective fuel switch	Replace switch

COMPRESSOR SHUTS DOWN

SYMPTOM	PROBABLE CAUSE	REMEDY
NO FLASH CODE:	Blown fuse in wiring harness	Remove/inspect fuse and replace if necessary
	Instrument panel connectors loose or disconnected	Check instrument panel connectors and reattach if required
		Check instrument panel wires for broken connections or corrosion. Clean and/or replace if required
Faulty SSAM module	Replace the SSAM module	
SSAM FLASH CODE: ONE FLASH	Compressor temperature switch is open	Check wiring connection to switch and tighten as required
		Check switch continuity when cool and replace if necessary
	Cooling air flow is insufficient	Clean the cooler and check for proper ventilation
	Low compressor receiver tank fluid level	Add fluid as required
	Clogged compressor fluid filter	Change the filter element
	Faulty thermostat	Change the thermostat element
	Loose or broken fan belt	Check the fan belt and tighten or replace if necessary
	Plugged fluid cooler tube (internal)	Replace the cooler

SECTION 5

COMPRESSOR SHUTS DOWN		
SYMPTOM	PROBABLE CAUSE	REMEDY
COMPRESSOR DOES NOT ACHIEVE FULL DISCHARGE PRESSURE	Run/start switch not in run position	For compressors with idle warm-up controls, switch toggle to RUN for full operation
	Air demand is excessive	Check service lines for leaks or open valves
	Dirty air filter	Check the filter and change the element if required
	Defective pressure regulator	Check the diaphragm and replace with Kit if necessary
	Defective idle warm-up control	Replace control
	Engine Warning/Shutdown lamp flashing—engine is derating	Turn the compressor OFF. Use PowerView menu and arrow keys to determine engine fault. Ignore the SSAM Flash Code. See the Engine Warning/Shutdown table for probable cause
IMPROPER UNLOADING WITH AN EXCESSIVE PRESSURE BUILD-UP CAUSING THE PRESSURE RELIEF VALVE TO OPEN	Pressure regulating valve is set too high	Readjust
	Control system leak causing loss of pressure signal	Check control lines
		Defective pressure regulating valve. Repair valve (kit available)
	Inlet valve jammed	Free or replace valve
	Restriction in the control system	Check all control lines and components—ice and/or other contaminants could be the cause
	Defective pressure relief valve opens when pressure is too low	Replace the pressure relief valve
Defective pressure regulator	Check the diaphragm and replace with Kit if necessary	
INSUFFICIENT AIR DELIVERY	Run/start switch not in run position	For compressors with idle warm-up controls, switch toggle to RUN for full operation
	Plugged air filter	Replace
	Defective idle warm-up control	Replace control
	Plugged air/fluid separator	Replace separator element and also change compressor fluid and fluid filter
	Defective pressure regulator	Adjust or repair
	Engine speed too low	Readjust engine speed
	Engine Warning/Shutdown lamp flashing—engine is derating	Turn the compressor OFF. Use PowerView menu and arrow keys to determine engine fault. Ignore the SSAM Flash Code. See the Engine Warning/Shutdown table for probable cause
EXCESSIVE COMPRESSOR FLUID CONSUMPTION	Clogged return line	Clear orifice and return line strainer
	Lubrication system leak	Check all pipes, connections and components
	Separator element damaged or malfunctioning	Change separator element

COMPRESSOR SHUTS DOWN		
SYMPTOM	PROBABLE CAUSE	REMEDY
COMPRESSOR OVERHEATING	Low receiver tank fluid level	Fill receiver tank
	Loose or broken fan belt	Tighten or replace belt
	Dirty fluid cooler core	Clean core thoroughly
	Plugged compressor fluid filter	Change element
	Faulty thermostat	Change thermostat element
	Plugged fluid cooler tube (internal)	Replace cooler
ENGINE OVERHEATING	Loose or broken fan belt	Tighten or replace belt
	Dirty radiator core	Clean thoroughly
	Low fluid level	Refill
	Faulty water pump	Change pump
	Plugged radiator	Clean and flush thoroughly
	Defective engine thermostat	Replace

THIS PAGE INTENTIONALLY LEFT BLANK



Section 6

NOISE CONTROL

6.1 NOISE EMISSIONS WARRANTY

Sullair Corporation warrants to the ultimate purchaser and each subsequent purchaser that this air compressor was designed, built and equipped to conform at the time of sale to the first retail purchaser, with all applicable U.S. E.P.A. and/or any Federal, State or Local noise control regulations.

This warranty is not limited to any particular part, component, or system of the air compressor. Defects in the design, assembly, or in any part, component, or system of the compressor which, at the time of sale to the first retail purchaser, caused noise emissions to exceed Federal standards are covered by this warranty for the life of the air compressor.

6.2 TAMPERING WITH THE NOISE CONTROL SYSTEM IS PROHIBITED

Federal Law prohibits the following acts or the causing thereof:

1. The removal or rendering inoperative by any persons, other than for purposes of maintenance, repair, or replacement, of any device or element of design incorporated into any new compressor for the purpose of noise control prior to its sale or delivery to the ultimate purchaser or while it is in use.
 2. The use of the compressor after such device or element of design has been removed or rendered inoperative by any person.
- Among those acts included in the prohibition against tampering are the acts listed below:
1. Removal or rendering inoperative any of the following:
 - a. Engine exhaust system or parts thereof
 - b. Compressor air intake system or part thereof
 - c. Enclosure of part thereof
 2. Removal of any of the following:
 - a. Vibration isolators
 - b. Control silencer
 - c. Floor panel
 - d. Fan shroud
 - e. Acoustical materials including fiberglass foam or foam tape
 3. Operation with canopy doors open for any purpose other than starting, stopping, adjustment, repair, replacement of parts or maintenance.

6.3 NOISE EMISSIONS MAINTENANCE AND MAINTENANCE RECORD LOG

The following instructions and maintenance record log book, for the proper maintenance, use and repair of this compressor, is intended to prevent noise emission degradation.

Noise Emission Maintenance and Maintenance Record Log

1. ANNUAL MUFFLER AND EXHAUST SYSTEM INSPECTION
At least annually inspect muffler(s) and engine exhaust system to make sure all parts are securely mounted, that all joints and connections are tight, and that the muffler is in good condition. DO NOT operate compressor with defective exhaust system. Remove and replace any defective parts by ordering with part numbers indicated in the Parts List.
Maintenance Performed
By
Location
Date
Maintenance Performed
By
Location
Date
2. ANNUAL AIR FILTER(S) AND AIR INLET SYSTEM INSPECTION
In addition to the instructions in the Maintenance section of the Operator's Manual, the air filter(s) and entire air inlet system should be inspected at least annually, to make sure all parts are securely mounted, that all joints and connections are tight, that there are no other leaks in the system, and that the filter element(s) are intact. DO NOT operate compressor with defective air inlet system. Remove and replace defective parts by ordering with part numbers indicated in the Parts List.
Maintenance Performed
By
Location
Date
Maintenance Performed
By
Location
Date

3. ANNUAL ENGINE VIBRATION MOUNT INSPECTION
At least annually inspect engine vibration mounts for security of attachment and to make sure the resilient parts are intact. DO NOT operate compressor with defective engine mounting system. Remove and replace defective parts by ordering with part numbers indicated in Parts List.
Maintenance Performed
By
Location
Date
Maintenance Performed
By
Location
Date

4. ANNUAL FRAME, CANOPY, AND PARTS INSPECTION
At least annually inspect frame, canopy and parts, for security of attachment. Make sure there are not any missing or deformed members, including all hinged doors, covers and their fastening devices. DO NOT operate compressor with defective frame, canopy and parts. Remove and replace defective parts by ordering with part numbers indicated in Parts List.
Maintenance Performed
By
Location
Date
Maintenance Performed
By
Location
Date

5. ANNUAL ACOUSTICAL MATERIALS INSPECTION
At least annually inspect all acoustical materials, if any, for security of attachment. Make sure that there is not any material missing or damaged (refer to Parts List). Clean or replace, if necessary. DO NOT operate compressor with defective acoustical material. Remove and replace defective parts by ordering with part numbers indicated in the Parts List.
Maintenance Performed
By
Location
Date
Maintenance Performed
By
Location
Date

SECTION 6

6. ANNUAL INSPECTIONS FOR PROPER OPERATION OF ALL SYSTEMS.

In addition to other instructions in the Operator's Manual, at least annually, operate compressor and inspect to make sure all systems are operating properly and that engine runs at rated speed and pressure. DO NOT operate malfunctioning or improperly adjusted compressor. Repair or adjust, per instructions in Operator's Manual, as required.

Maintenance Performed

By

Location

Date

Maintenance Performed

By

Location

Date



Section 7

ILLUSTRATIONS AND PARTS LIST

7.1 PROCEDURE FOR ORDERING PARTS

Parts should be ordered from the nearest Sullair representative or the representative from whom the compressor was purchased. If parts cannot be obtained from these sources, contact the factory directly at the addresses, fax or phone numbers listed on following page.

When ordering parts always indicate the Serial Number of the compressor. This can be obtained from the compressor's bill of lading or the Serial Number Plate on the front of the compressor (see *Figure 7-1*).

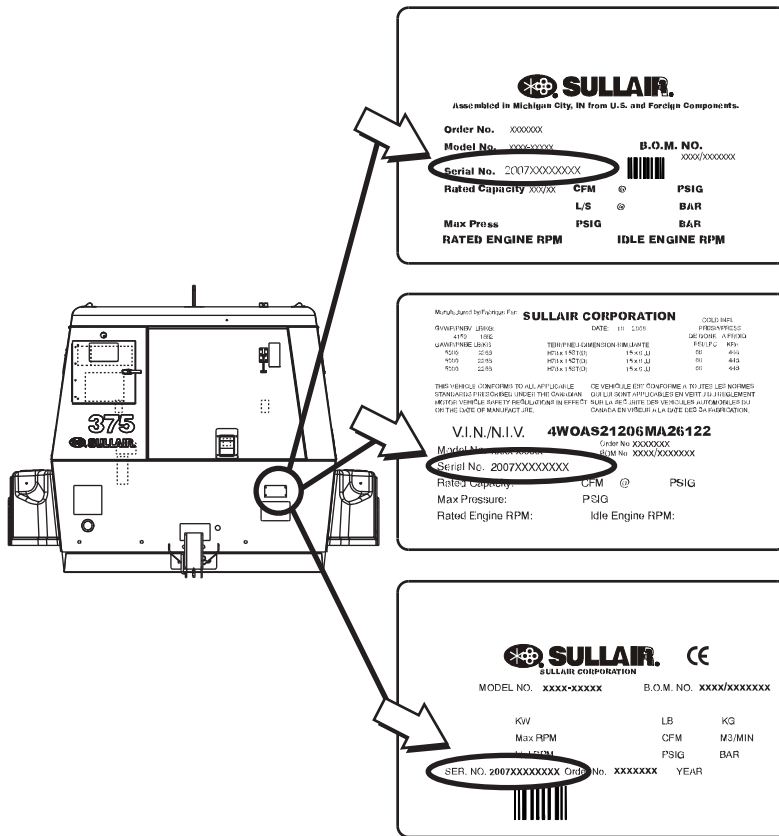

SU_0000675

Figure 7-1: Serial Number Plate Location

SULLAIR ASIA, LTD.

Sullair Road, No. 1
Chiwan, Shekou
Shenzhen, Guangdong PRV.
PRC POST CODE 518068
Telephone: 755-6851686
Fax: 755-6853473
www.sullair-asia.com

SULLAIR CORPORATION

3700 East Michigan Boulevard
Michigan City, Indiana 46360 U.S.A.
www.sullair.com
Telephone: 1-800-SULLAIR (U.S.A. Only)
or 1-219-879-5451
Fax: (219) 874-1273

CUSTOMER CARE PARTS

1-888-SULLAIR (785-5247)
Fax: (219) 874-1835
www.sullair.com

SERVICE

1-888-775-1604 (U.S.A. & Canada Only)
Fax: (219) 874-1205
www.sullair.com

SULLAIR EUROPE, S.A.

Zone Des Granges BP 82
42602 Montbrison Cedex, France
Telephone: 33-477968470
Fax: 33-477968499
www.sullaireurope.com

CHAMPION COMPRESSORS, LTD.

Princess Highway
Hallam, Victoria 3803
Australia
1800-810-015
(for Australia wide branch network only)
Telephone: 61-3-9796-4000
Fax: 61-3-9703-8053
www.championcompressors.com.au

7.2 RECOMMENDED SPARE PARTS LIST

Key	Description	Part Number	Note	Quantity
1	element for air filter assy (primary)	02250164-532		2
2	element for air filter assy (secondary)	02250164-533		2
3	element for main compressor fluid filter 250025-521	250025-525		1
4	element for air/fluid separator	250034-087		1
5	element for 1st stage discharge filter (aftercooled)	02250153-293		1
6	element for 2nd stage discharge filter (aftercooled)	02250153-304		1
7	element for engine oil filter	02250083-017		1
8	element for engine primary fuel filter	02250168-191		1
9	element for final fuel filter	02250168-192		1
10	repair kit for thermal valve 02250113-796	044583		1
11	repair kit for flange SAE O-ring	02250099-416		1
12	repair kit for pressure regulator valve 250017-280	250019-453		1
13	repair kit for inlet valve 250026-779	250029-249		1
14	repair kit for return line strainer 241771	241772		1
15	repair kit for minimum pressure/check valve 02250094-294	250019-444		1
16	repair kit for shaft seal	602541-002		1
17	repair coupling assemblies (375)	250031-586		1
18	repair coupling assemblies (300HH, 375H, & 425)	250024-470		1
19	Sullair AWF (5 gallons/18.9 liters)	250030-757		1
20	Sullair AWF (55 gallon drum/208 liters)	250030-758		1
21	manual, CIMA safety	250023-146		1
22	manual, Portable Component Service	02250056-343		1
23	repair kit for regulator/blowdown valve manifold	02250147-737		1

NOTE

When ordering parts, indicate the serial number of the compressor.

7.3 ENGINE, COMPRESSOR AND PARTS

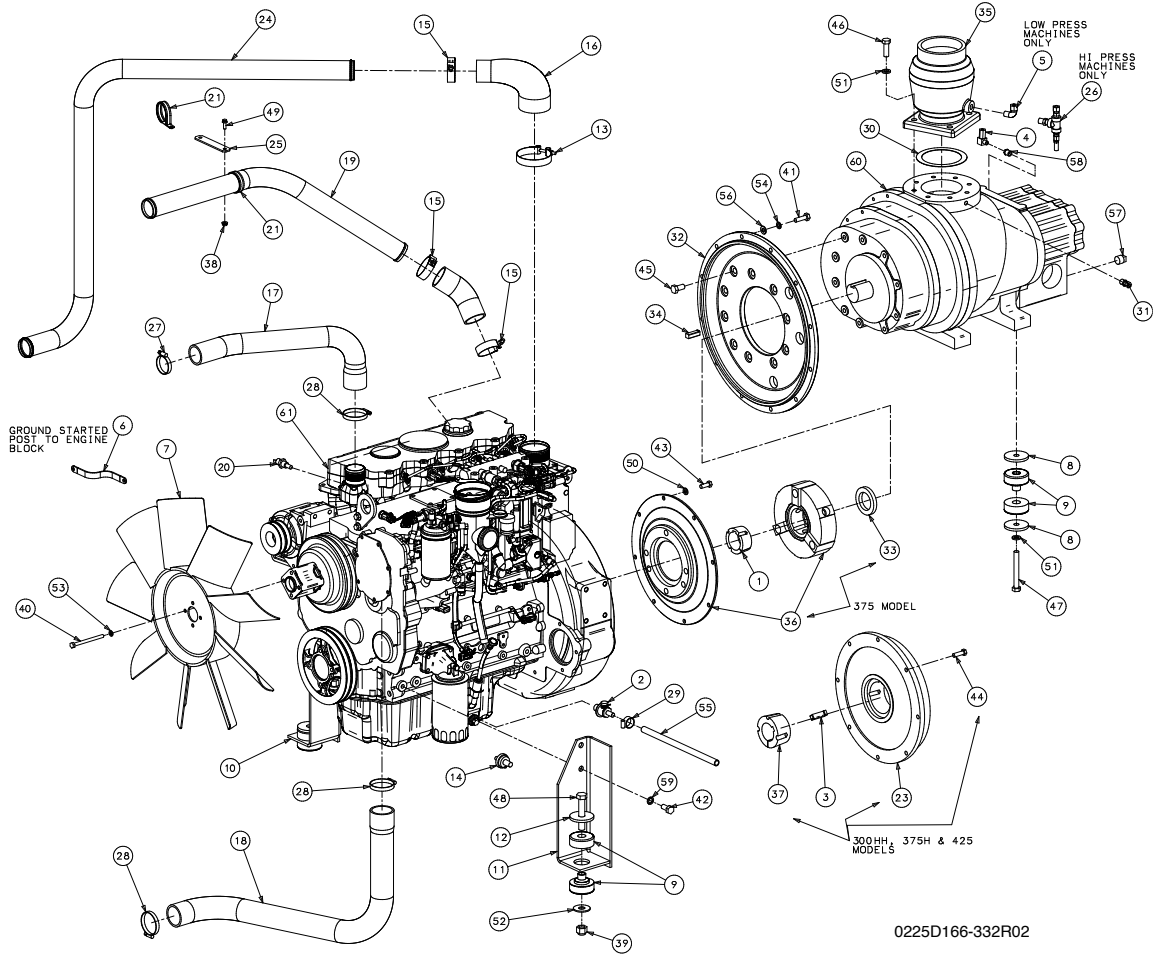

7.3 ENGINE, COMPRESSOR AND PARTS (CONTINUED)

Key	Description	Part Number	Note	Quantity
1	bushing, taperlock 2012	02250049-415		1
2	valve, drain eng oil 19mm x 1.50	02250051-231		1
3	key, shaft step 375h	02250053-263		1
4	elbow, check valve 1/4t x 1/8p	02250058-275		1
5	elbow, 90 3/8" tube x 1/4"npt m	02250099-626		1
6	cable, ground 4-gauge strap	02250101-258		1
7	fan, blower 25" 300h-425 cat	02250115-570		1
8	washer, snubbing vibration mount	02250125-471		4
9	mount, vibration isolator 375	02250125-473		4
10	support, engine front rh cat	02250125-479		1
11	support, engine front lh cat	02250125-480		1
12	washer, snubbing 375 vibration mount	02250125-604		2
13	clamp, t-bolt ss band 3.50" id	02250129-227		1
14	switch, engine oil pressure n.o.	02250130-668		1
15	clamp, t-bolt ss band 2 1/4" id	02250137-795		3
16	elbow, silicone cac reducing 2 x 3	02250137-802		1
17	hose, rad upper cat 375 tier ii	02250138-190		1
18	hose, rad lower cat 375 tier ii	02250138-191		1
19	pipe, cac hot/upper cat t2	02250138-194		1
20	switch, engine hi-temp 225f nc 1/2 npt	02250138-450		1
21	clamp, 2" id high temp	02250140-362		1
22	elbow, silicone cac 2" id x 45 deg	02250145-483		1
23	coupling, assembly ringfedder ac-t4.1	02250146-634		1
24	tube, cac hot sd 375 cat t3	02250164-546		1
25	strap, cac pipe supt 375 ca t3	02250166-753		1
26	sub assembly, control orifice 375h jd t3	02250168-182	(l)	1
27	clamp, hose 1 5/16" to 2 1/4" adj.	040014		1
28	clamp, hose 1 13/16" x 2 3/4" adj.	040083		3
29	clamp, hose 13/16" to 1-1/2"	040513		1
30	gasket, 1/32 x 5 1/4 od x 4 1/8 id	040708		1
31	connector, 1/4t x 1/4 npt str	250018-428		1
32	adapter, eng-compr 375 jd	250022-732		1
33	spacer, coupling 375 jd & cat	250023-218		1
34	key, shaft 375	250023-340		1
35	valve, air inlet 4" 375 dpq	250026-779		1
36	coupling assy 375 jd & cat	250031-586		1
37	bushing, taper-loc 2517 1.93id	407848		1
38	nut, hex f pltd 1/4-20	825304-236		1
39	nut, hex locking 5/8-11	825510-329		2
40	capscrew, hex 8.8 m8 x 100mm	828008-100		4
41	capscrew, hex 8.8 m10 x 35mm	828010-035		12
42	capscrew, hex 8.8 m12 x 25mm	828012-025		4

7.3 ENGINE, COMPRESSOR AND PARTS (CONTINUED)

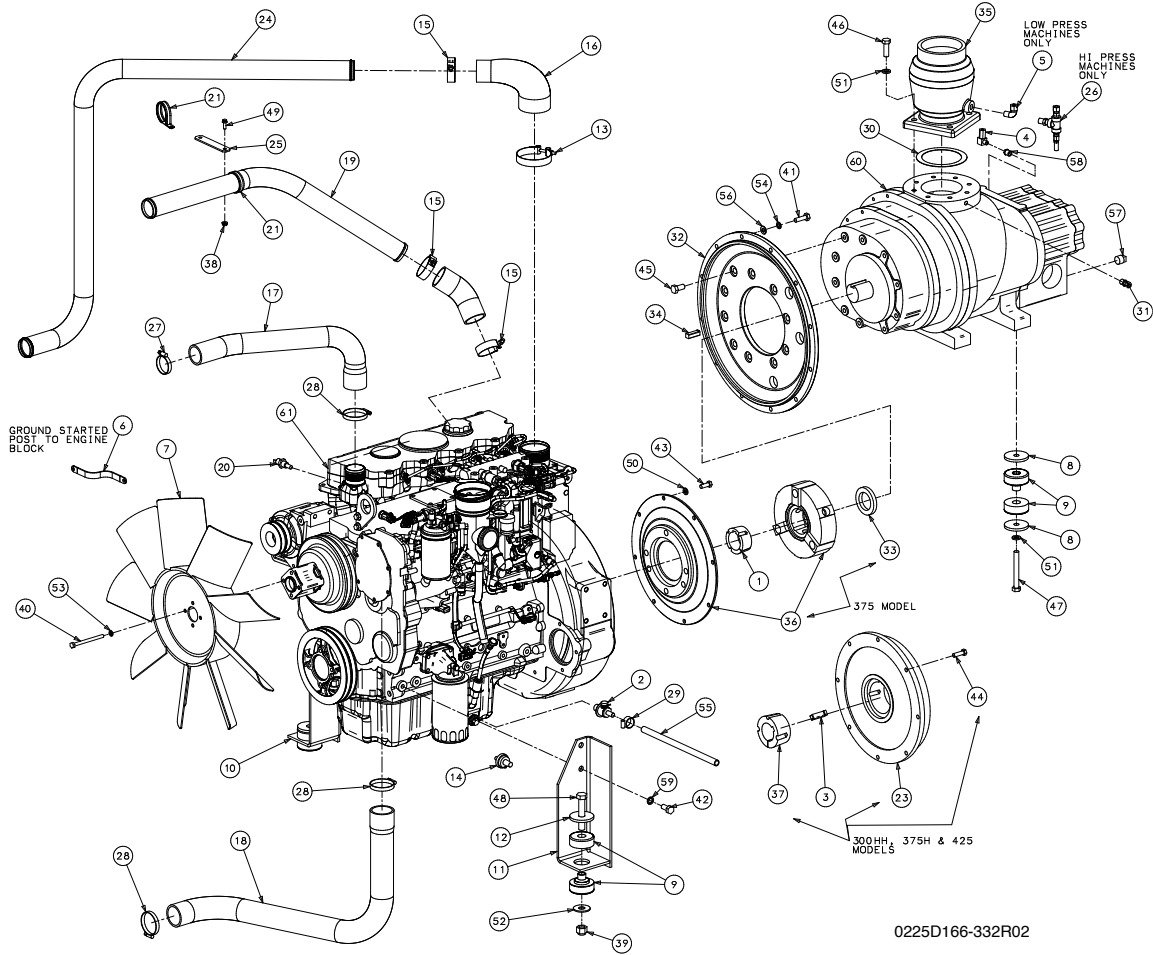

0225D166-332R02

7.3 ENGINE, COMPRESSOR AND PARTS (CONTINUED)

Key	Description	Part Number	Note	Quantity
43	capscrew, hex gr5 3/8-16 x 1	829106-100		8
44	capscrew, hex gr5 3/8-16 x 1 1/4	829106-125		8
45	capscrew, hex gr5 1/2-13 x 1	829108-100		10
46	capscrew, hex gr5 1/2-13 x 1 1/2	829108-150		4
47	capscrew, hex gr5 1/2-13 x 4	829108-400		2
48	capscrew, hex gr5 5/8-11 x 3 1/2	829110-350		2
49	screw, hex ser washer 1/4-20 x 3/4	829704-075		1
50	washer, spr lock reg pltd 3/8	837806-094		8
51	washer, spr lock reg pltd 1/2	837808-125		6
52	washer, pl-b reg pltd 5/8	838210-112		2
53	washer, spr lock-metric pltd m8	838808-200		4
54	washer, spr lock-metric pltd m10	838810-220		12
55	hose, heater 1/2" (ft)	842115-050		1
56	washer, metric-iso7089- 10	865410-210		12
57	plug, pipe 1/2" 3000# stl plt	866900-020		1
58	bushing, red pltd 1/4 x 1/8	867100-005		1
59	washer, nord-lock pl 1/2"	878608-077		4
60	unit, 16 series 375	consult factory		1
61	engine, cat 4.4 130hp t	consult factory		1

(I) See page 92.

7.4 RADIATOR & COMPRESSOR FLUID COOLING SYSTEM

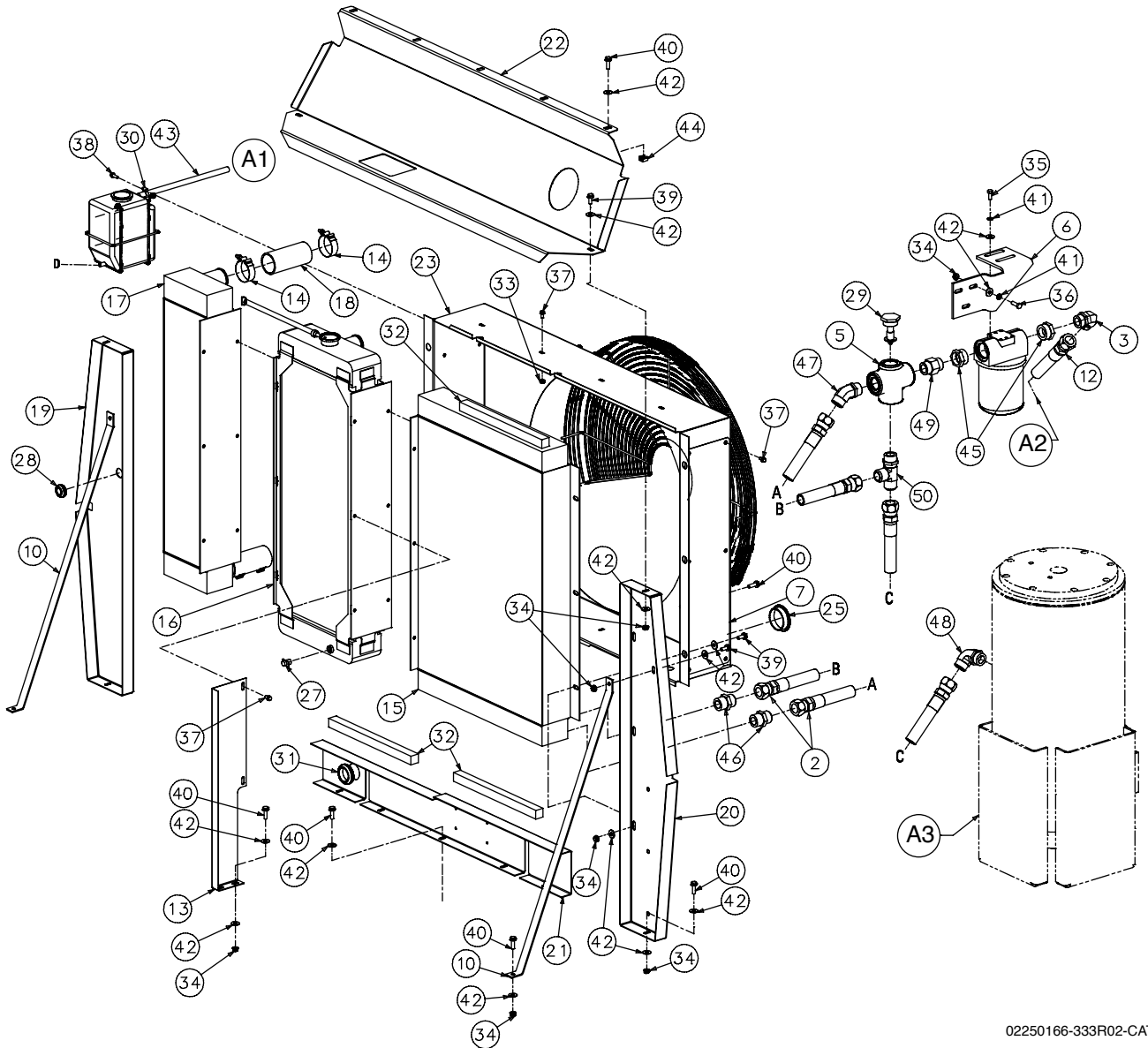

02250166-333R02-CAT

7.4 RADIATOR & COMPRESSOR FLUID COOLING SYSTEM (CONTINUED)

Key	Description	Part Number	Note	Quantity
1	bucket, radiator fluid recovery	02250083-466		1
2	hose, mp 1" x 48" lg	02250088-283		2
3	elb, 90 sae x orfs 1.25" x 1.00"	02250093-804		1
4	filter, fluid 1 5/8 sae str thrd co	02250096-783		1
5	housing, thermo vlv leak free 375	02250113-796		1
6	support, oil filter thrm-vlv 375	02250114-008		1
7	plate, access 375 after clr	02250116-321		1
10	support, cooler assy 375 dpq	02250119-030		2
12	hose, mp orfs f-swvl 1"	02250135-593		1
13	support, cooler center brace	02250137-235		1
14	clamp, t-bolt ss band 2 1/4" id	02250137-795		4
15	cooler, oil 375 jd/cat tier ii	02250137-798		1
16	radiator, 300h-425q jd/cat tier ii	02250137-799		1
17	cooler, cac 375 jd/cat tier ii	02250137-800		1
18	adapter, cac pipe 2" id x 6" lg	02250138-196		2
19	baffle, clrs. r.h. 375-425 t3	02250164-454		1
20	baffle, clrs. lh 375-425 t3	02250164-455		1
21	baffle, clrs bottom 375-425 t3	02250164-456		1
22	baffle, clrs top 375-425 t3	02250164-457		1
23	shroud, fan 26" 375-425 jd t3	02250164-458		1
25	plug, finishing 2.5" steel	02250164-475		2
26	guard, fan 28" 375-600t3	02250164-542		1
27	drainlock, 1/4"	040061		1
28	grommet, rubber 1" hole	040162		1
29	element, thrm vlv (155 deg f)	044583		1
30	clamp, hose 3/8"	047235		1
31	grommet, rubber 1-3/4" hole	250020-358		1
32	weatherstrip, 1" thick x 1" wide (ft) -	250041-174		7
33	nut, hex f pltd 1/4-20	825304-236		8
34	nut, hex f pltd 5/16-18	825305-283		19
35	capscrew, hex gr5 5/16-18 x 3/4	829105-075		4
36	capscrew, hex gr5 5/16-18 x 1	829105-100		3
37	screw, hex ser washer 1/4-20 x 1/2	829704-050		26
38	screw, hex ser washer 1/4-20 x 3/4	829704-075		2
39	screw, hex ser washer 5/16-18 x 3/4	829705-075		10
40	screw, hex ser washer 5/16-18 x 1	829705-100		20
41	washer, spr lock reg pltd 5/16	837805-078		7
42	washer, pl-b reg pltd 5/16	838205-071		45
43	hose, fuel line 5/16 (ft)	842315-031		3

7.4 RADIATOR & COMPRESSOR FLUID COOLING SYSTEM (CONTINUED)

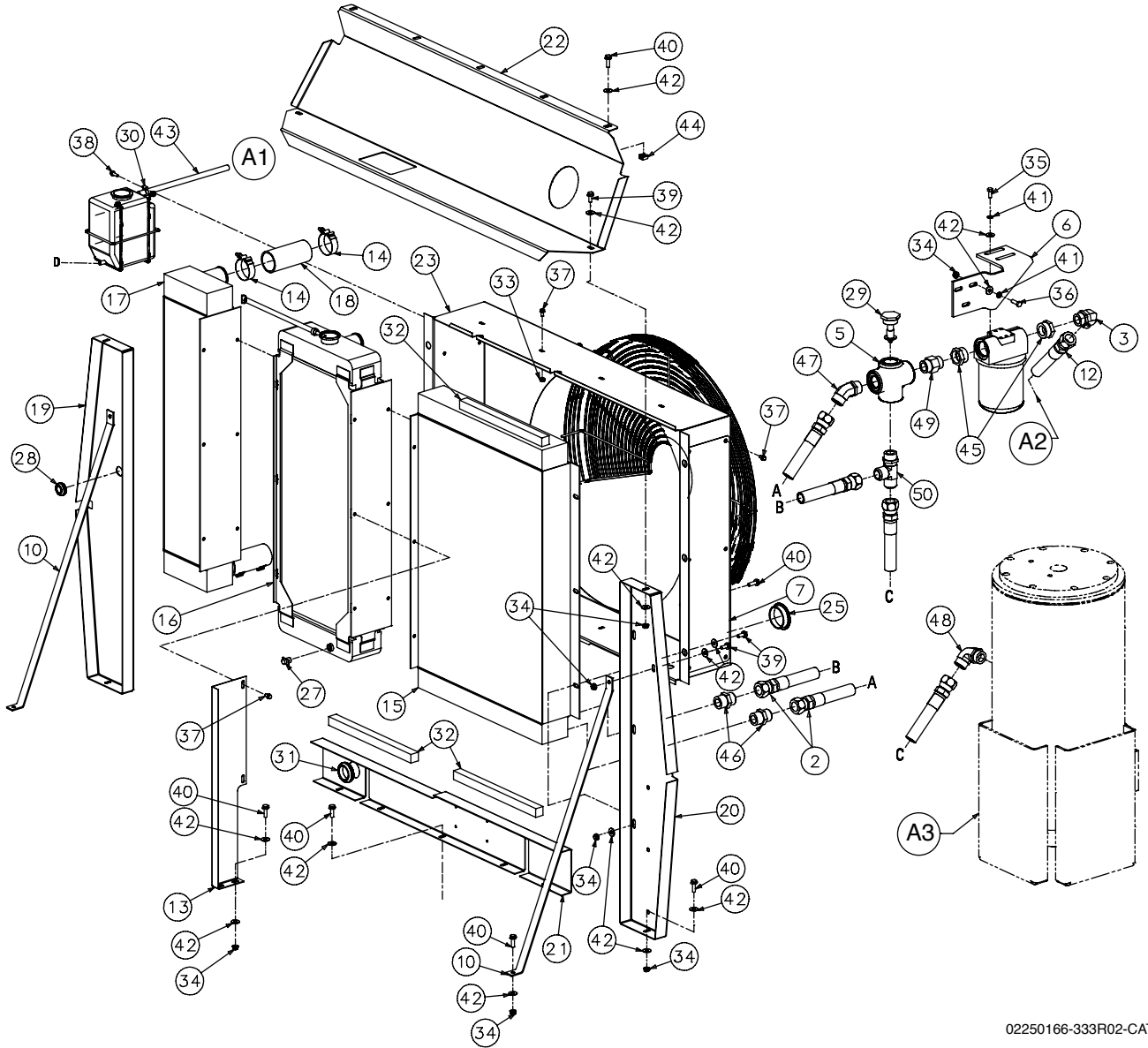

02250166-333R02-CAT

7.4 RADIATOR & COMPRESSOR FLUID COOLING SYSTEM (CONTINUED)

Key	Description	Part Number	Note	Quantity
44	nut, retainer 5/16-18 .092	861405-092		5
45	reducer, str thrd viton 1 1/4 x 1	870020-016		2
46	connector, straight x jic 1 5/16 x 1 5/16	870116-016		2
47	connector, 45 deg str x jic 1 5/16 x 1 5/16	870516-016		1
48	connector, 90d str x jic 1 5/16 x 1 5/16	870616-016		1
49	union, straight thrd 1 5/16-12	871316-131		1
50	tee, run 37fl str thd 1 5/16-12	871916-131		1
A1	Overflow to bottom of frame.			
A2	To unit fluid supply.			
A3	Air fluid separator tank assembly (reference).			

NOTE: For connection "D" to "D" use clear plastic tubing and clamps supplied with overflow bottle.

7.5 AIR INLET SYSTEM & EXHAUST SYSTEM

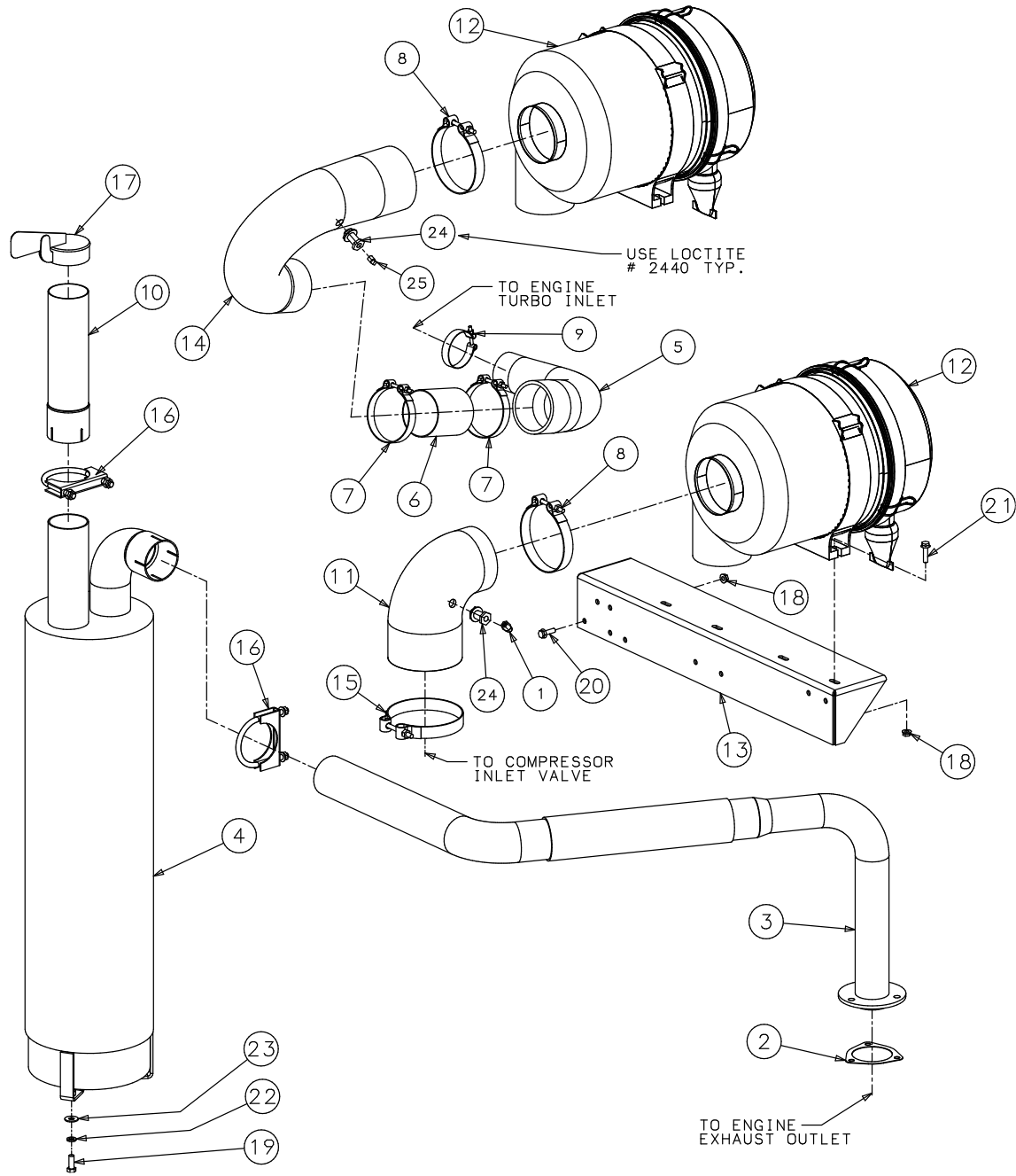

02250166-339R00

7.5 AIR INLET SYSTEM & EXHAUST SYSTEM (CONTINUED)

Key	Description	Part Number	Note	Quantity
1	elbow, 90m 5/16"tube x 1/8"npt -	02250109-423		1
2	gasket, exht ca3054na 185q	02250110-425		1
3	tube,exhaust 375-425 cat	02250115-010		1
4	muffler, exhaust 300h-425 ft mtg	02250115-201		1
5	hose, air inlet eng (part 1)	02250140-336		1
6	tube, aluminum 3.5"od x 4"lg 16ga	02250140-363		1
7	clamp, t-bolt ss band 4.00"id	02250140-869		2
8	clamp, t-bolt ss band 5.00"id	02250140-870		2
9	clamp, t-bolt ss band 2.75"id	02250152-375		1
10	tube,exhst ext 375-600q t3	02250164-526		1
11	elbow,air inl compr 375-600 t3	02250164-530		1
12	filter, air inl 375-600 cfm	02250164-531		2
13	support, air fltrs 375 t3	02250164-534		1
14	hose,eng inl 375 t3	02250164-547		1
15	clamp, t-bolt ss band 5.50"id	042324		1
16	clamp. exhaust 3"	043713		2
17	cap, rain exhaust 3"	047208		1
18	nut,hex f pltd 5/16-18	825305-283		7
19	capscrew,hex gr5 3/8-16 x 1	829106-100		3
20	screw, hex ser washer 5/16-18 x 1	829705-100		3
21	screw, hex ser washer 5/16-18 x 1 1/4	829705-125		4
22	washer, spr lock reg pltd 3/8	837806-094		3
23	washer, pl-b reg pltd 3/8	838206-071		3
24	bulkhead, pipe 1/8" npt	841500-002		2
25	plug, pipe 1/8" 3000# stl plt	866900-005		1

7.6 CONTROL PARTS & DISCHARGE PARTS - 375 AND 425

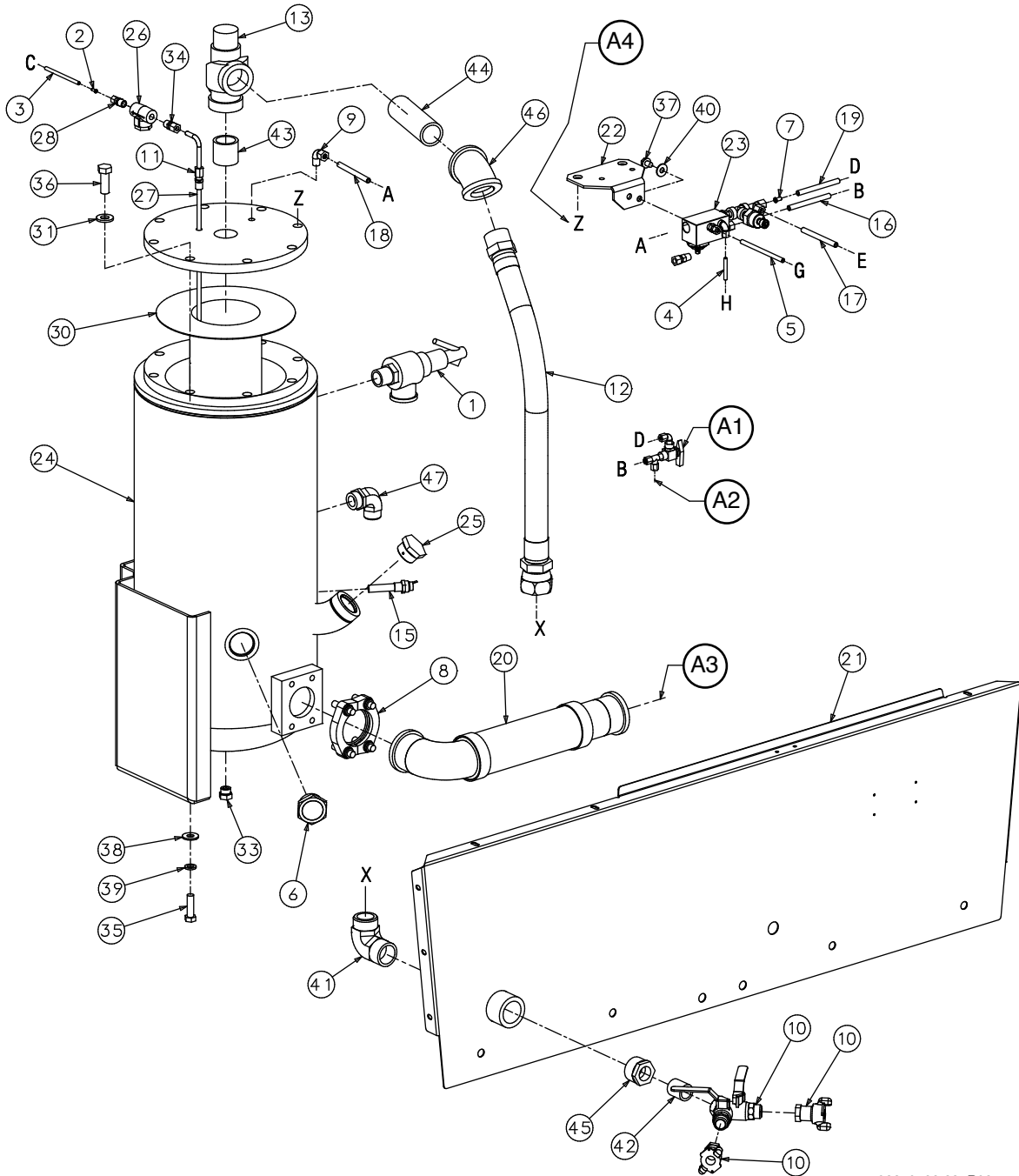

02250166-335R03

7.6 CONTROL PARTS & DISCHARGE PARTS - 375 AND 425 (CONTINUED)

Key	Description	Part Number	Note	Quantity
1	valve, relief 1" npt x 1 1/4" fnpt 200 psig	02250047-679		1
2	insert, nylon tubing 1/4" od	02250052-841		4
3	tube, nyl .25 od x .040w wht (ft)	02250054-860		4
4	tube, nyl .25 od x .040w blk (ft)	02250054-861		3
5	tube, 5/16 od x .040 wall	02250081-220		3
6	plug, sight glass 1-7/8" sae	02250097-611		1
7	insert, nyl tubing 3/8" od	02250099-052		8
8	flange, kit sae splt 2.5" - viton	02250099-416	(I)	2
9	elbow, 90 3/8" tube x 1/4" npt m	02250099-626		1
10	sub assembly, service valves std 375-425	02250118-603	(II)	1
11	connector, tube oil return 5/16 x 1/4	02250118-809		1
12	hose, air service std 375	02250119-080		1
13	valve, 1 1/2" npt min press chk	02250121-558		1
14	valve, ball 2-way 1/8" npt 90 deg	02250130-629		1
15	switch, temp n.c. 250°F, single pole	02250159-777		1
16	tubing, nylon 3/8" od red	02250139-950		3
17	tubing, nylon 3/8" od yellow	02250139-951		4
18	tubing, nylon 3/8" od blue	02250139-953		2
19	tubing, nylon 3/8" od orange	02250139-954		3
20	hose, discharge 375-600 dpq	02250164-548		1
21	panel, frm frt 375-600 t3	02250164-704	(III)	1
22	support, reg/bd assy 375-600 t3	02250166-243		1
23	sub assembly, reg/bd assy 375 t3	02250166-244	(IV)	1
24	tank, air-oil sep 300HH-600	02250170-513		1
25	plug, o-ring boss sae 1 1/4	040029		1
26	strainer, v-type 300 psi x 1/4	241771		1
27	tube, steel 5/16" od oil siphon	250009-253		1
28	connector, 1/4t x 1/4 npt str	250018-428		1
29	elbow, 90 1/4" tube x 1/8" npt	250018-429		1
30	element, oil sep 8.81 x 11.18	250034-087		1
31	washer, .625 hardened	250040-100		8
32	tee, m run 1/4t plsx 1/8 npt	250041-088		1
33	plug, str thd 3/4-16 sae vit	250042-623		1
34	connector, tube-male 5/16 x 1/4	812205-025		1
35	capscrew, hex gr8 1/2-13 x 1 3/4	828208-175		4
36	capscrew, hex gr5 5/8-11 x 1 3/4	829110-175		8
37	screw, hex ser washer 3/8-16 x 1/2	829706-050		2
38	washer, pl-b reg unfin 1/2	837208-112		4
39	washer, spr lock 1/2	837508-125		4
40	washer, pl-b reg pltd 3/8	838206-071		2
41	elbow, 37fl 90m 1 1/2 x 1 1/2	860224-150		1
42	nipple, pipe-xs plt 1 x cl	866416-000		1
43	nipple, pipe-xs plt 1 1/2 x cl	866424-000		1

7.6 CONTROL PARTS & DISCHARGE PARTS - 375 AND 425 (CONTINUED)

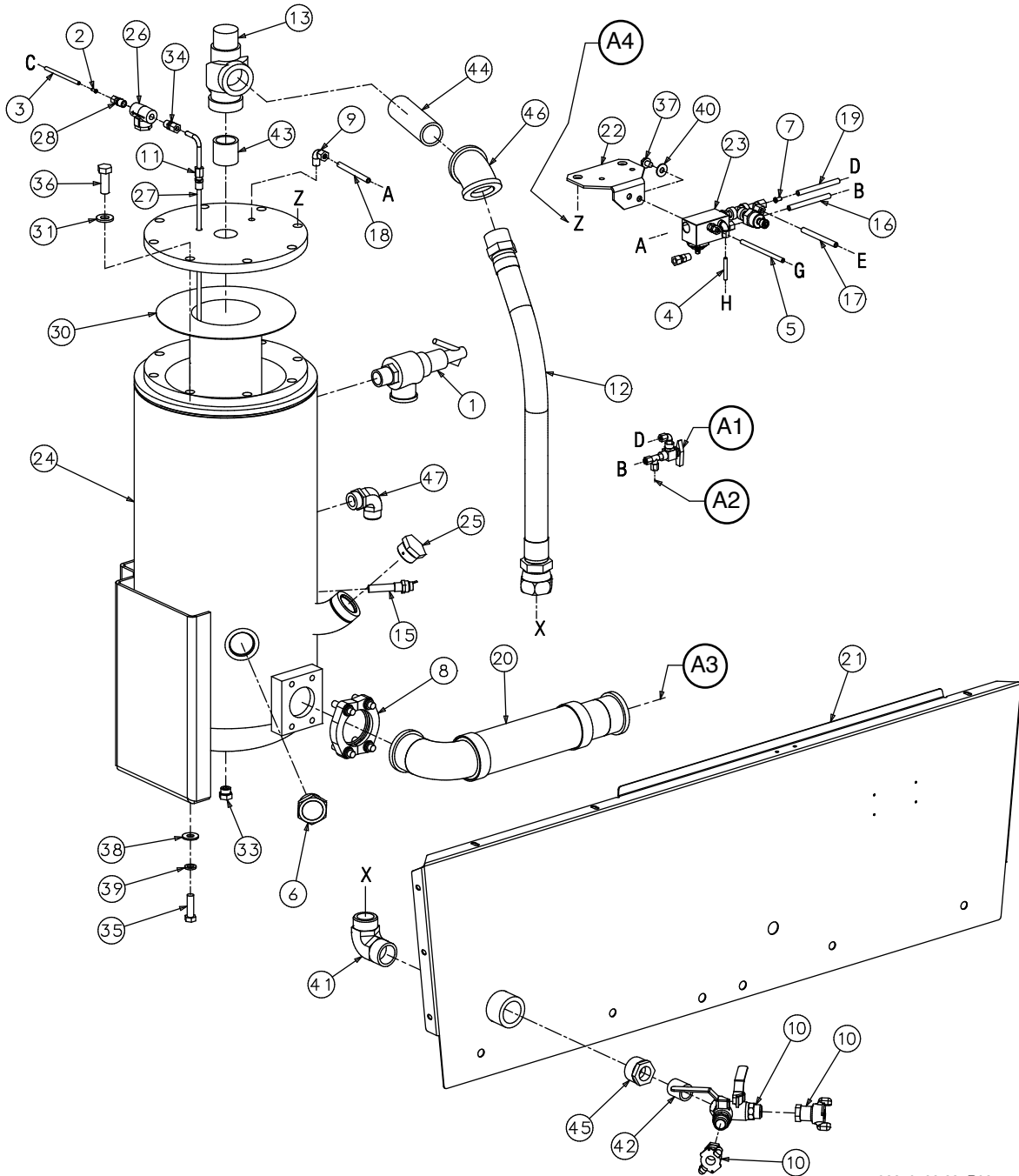

02250166-335R03

7.6 CONTROL PARTS & DISCHARGE PARTS - 375 AND 425 (CONTINUED)

Key	Description	Part Number	Note	Quantity
44	nipple, pipe-xs plt 1 1/2 x 6	866424-060		1
45	bushing, red pltd 1 1/2 x 1	867106-040		1
46	elbow, pipe 45 deg 300# plt 1 1/2"	869430-060		1
47	conn, 90d str x jic 1 5/16 x 1 5/16	870616-016		1
A	Shown 3/8" OD tubing blue			
B	To start run valve (end tee) 3/8 OD tubing red			
C	To unit oil return port 1/4" OD tubing white			
D	To start run valve (side) port 3/8" OD tubing orange			
E	To inlet valve 3/8" OD tubing yellow			
G	To inlet valve hose 5/16" OD white			
H	To unit (below inlet valve) 1/4" black			
A1	START/RUN warm-up valve at instrument panel			
A2	To pressure gauge			
A3	To unit			
A4	Line up "Z" and rotate CCW 90 degrees			
(I)	Replacement O-ring part number 826502-232.			
(II)	See page 94.			
(III)	For color variations consult factory.			
(IV)	See page 88.			

7.7 CONTROL PARTS & DISCHARGE PARTS - 300HH AND 375H

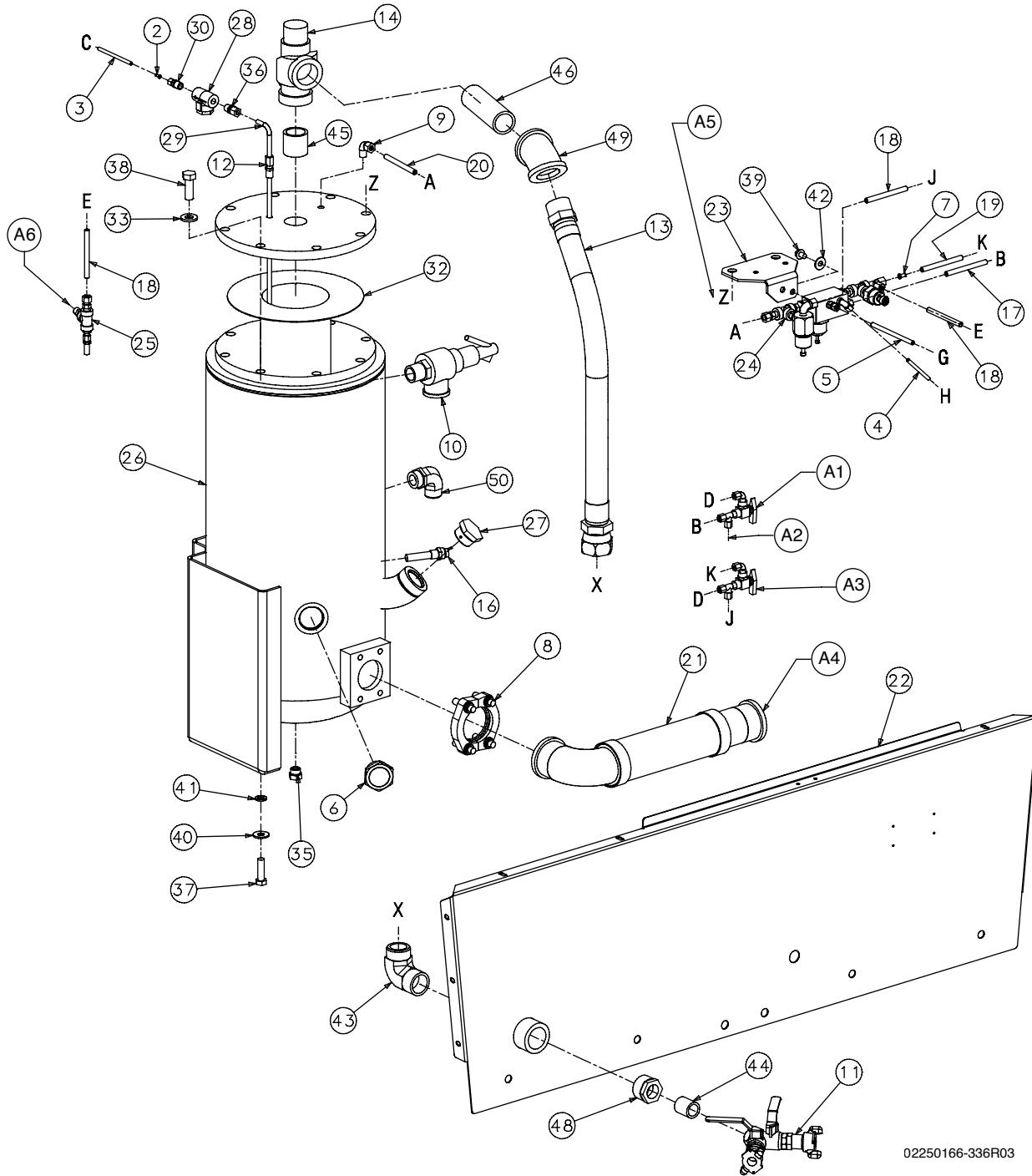

02250166-336R03

7.7 CONTROL PARTS & DISCHARGE PARTS - 300HH AND 375H (CONTINUED)

Key	Description	Part Number	Note	Quantity
2	insert, nylon tubing 1/4"od	02250052-841		4
3	tube, nyl .25 od x 040w wht(ft)	02250054-860		4
4	tube, nyl .25 od x .040w blk (ft)	02250054-861		3
5	tube, 5/16 od x .040 wall	02250081-220		3
6	plug, sight glass 1-7/8" sae	02250097-611		1
7	insert, nyl tubing 3/8"od	02250099-052		8
8	flange, kit sae splt 2.5" - viton	02250099-416	(I)	2
9	elbow, 90 3/8" tube x 1/4" npt m	02250099-626		1
10	valve, relief 1x1/4 250 psig	02250111-740		1
11	sub assembly, service valves std 375-425	02250118-603	(II)	1
12	connector, tube oil return 5/16x1/4	02250118-809		1
13	hose, air service std 375	02250119-080		1
14	valve, 1 1/2" npt min press chk	02250121-558		1
15	valve, ball 2-way 1/8" npt 90 deg	02250130-629		1
16	switch, temp n.c. 250°f, single pole	02250159-777		1
17	tubing, nylon 3/8" od red	02250139-950		3
18	tubing, nylon 3/8" od yellow	02250139-951		4
19	tubing, nylon 3/8" od green	02250139-952		2
20	tubing, nylon 3/8" od blue	02250139-953		2
21	hose, discharge 375-600 dpq	02250164-548		1
22	panel, frm frt 375-600 t3	02250164-704	(V)	1
23	support, reg/bd assy 375-600 t3	02250166-243		1
24	sub assembly, reg/bd assy 375 t3	02250166-245	(III)	1
25	sub assembly, control orifice	02250168-182	(IV)	1
26	tank, air-oil sep 300hh-600	02250170-513		1
27	plug, o-ring boss sae 1 1/4	040029		1
28	strainer, v-type 300 psix1/4	241771		1
29	tube, steel 5/16"od oil siphon	250009-253		1
30	connector, 1/4t x 1/4 npt str	250018-428		1
31	elbow, 90 1/4" tube x 1/8" npt	250018-429		1
32	element, oil sep 8.81 x 11.18	250034-087		1
33	washer, .625 hardened	250040-100		8
34	tee, m run 1/4t plsx 1/8 npt	250041-088		1
35	plug, str thd	250042-623		1
36	connector, tube-male 5/16 x 1/4	812205-025		1
37	capscrew, hex gr8 1/2-13 x 1 3/4	828208-175		4
38	capscrew, hex gr5 5/8-11 x 1 3/4	829110-175		8
39	screw, hex ser washer 3/8-16 x 1/2	829706-050		2
40	washer, pl-b reg unfin 1/2	837208-112		4
41	washer, spr lock 1/2	837508-125		4
42	washer, pl-b reg pltd 3/8	838206-071		2
43	elbow, 37fl 90m 1 1/2 x 1 1/2	860224-150		1
44	nipple, pipe-xs plt 1 x cl	866416-000		1
45	nipple, pipe-xs plt 1 1/2 x cl	866424-000		1

7.7 CONTROL PARTS & DISCHARGE PARTS - 300HH AND 375H (CONTINUED)

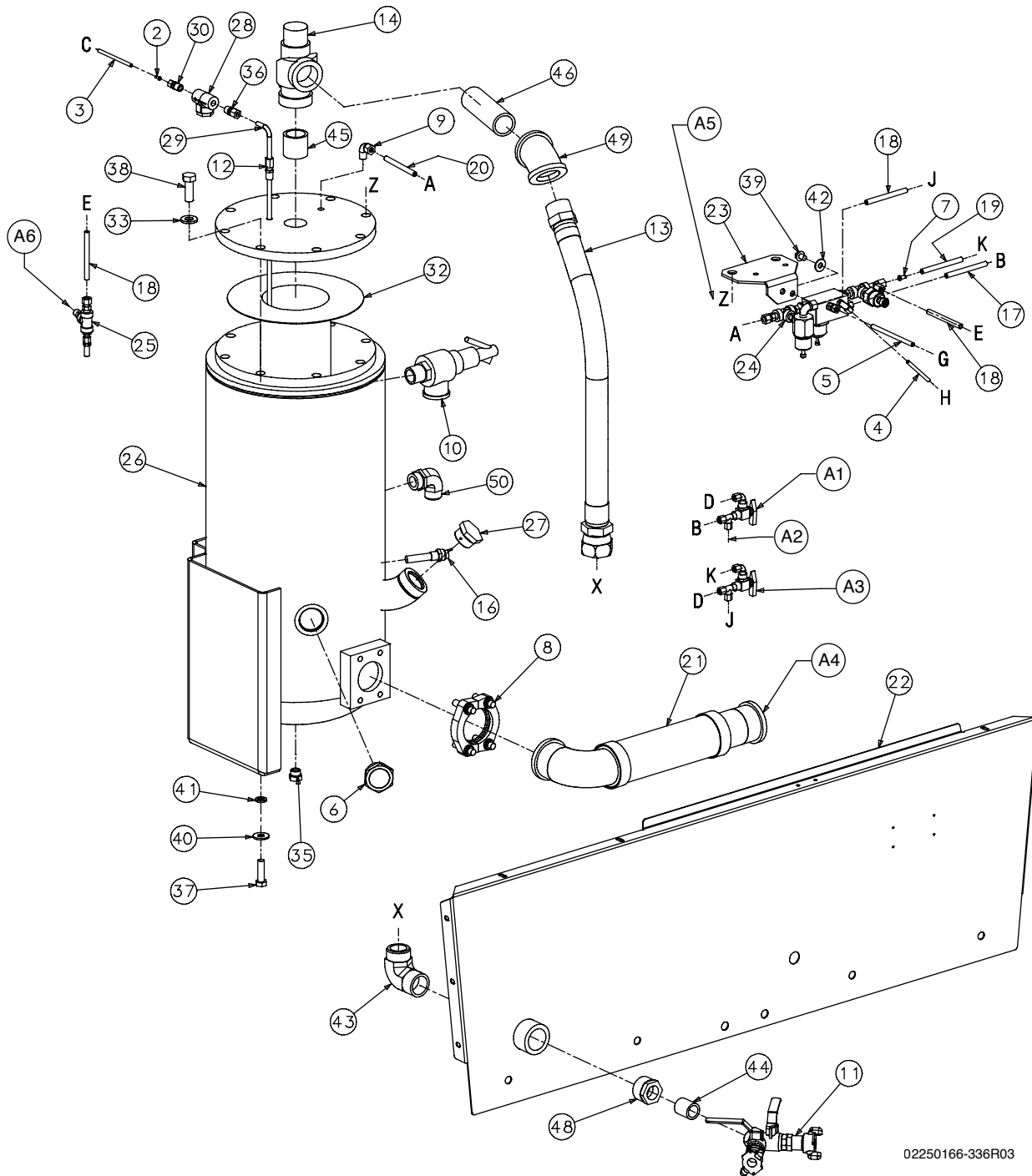

02250166-336R03

7.7 CONTROL PARTS & DISCHARGE PARTS - 300HH AND 375H (CONTINUED)

Key	Description	Part Number	Note	Quantity
46	nipple, pipe-xs plt 1 1/2 x 6	866424-060		1
47	bushing, red pltd 1 x 3/4	867104-030		1
48	bushing, red pltd 1 1/2 x 1	867106-040		1
49	elbow, pipe 45 deg 300# plt 1 1/2"	869430-060		1
50	connector, 90d str x jic 1 5/16 x 1 5/16	870616-016		1
A	Shown regulators to tank 3/8" OD tubing blue			
B	Shown start run valve (end tee) to reg block 3/8 OD tubing red			
C	To unit oil return port 1/4" OD tubing white			
D	Shown start vlv side port to hi-low vlv end port tee 3/8" OD orange			
E	Shown inlet control orifice to reg. assy 3/8" OD tubing yellow			
G	To inlet valve hose 5/16" OD white			
H	To unit (below inlet valve) 1/4 black			
J	Shown hi-low vlv (end port tee) to reg sa 3/8" OD tubing green			
K	Shown hi-low vlv (side port) to reg sa 3/8" OD tubing yellow			
A1	START/RUN warm-up valve at instrument panel			
A2	To pressure gauge			
A3	HI-LOW pressure gauge at instrument panel			
A4	To unit			
A5	Line up "Z" and rotate CCW 90 degrees			
A6	To inlet valve control			
(I)	Replacement O-ring part number 826502-232.			
(II)	See page 94.			
(III)	See page 90.			
(IV)	See page 92.			
(V)	For color variations consult factory.			

7.8 REGULATOR/BLOWDOWN VALVE - 375 AND 425

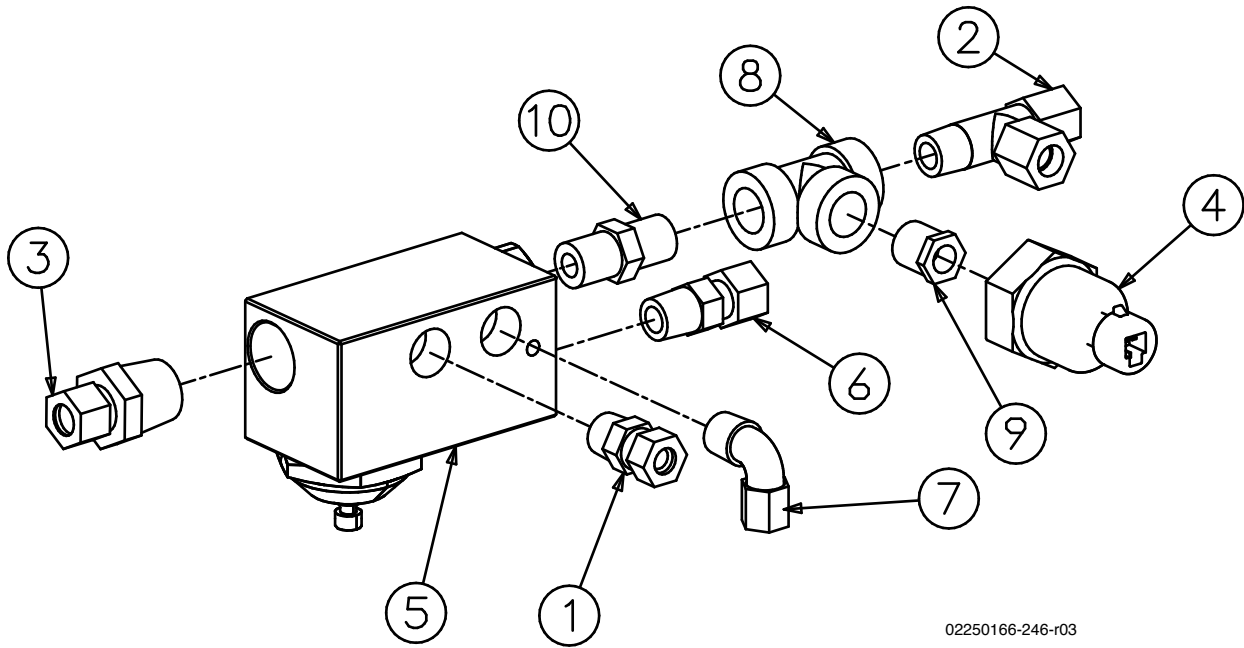

02250166-246-r03

7.8 REGULATOR/BLOWDOWN VALVE - 375 AND 425 (CONTINUED)

Key	Description	Part Number	Note	Quantity
1	connector, 5/16" tube x 1/4"npt	02250081-219		1
2	tee, m run 3/8" tube x 1/4"npt	02250099-615		1
3	connector, 3/8tube x 1/2npt	02250129-957		1
4	transducer, pressure 0-100psi 5volt n4	02250140-194		1
5	manifold, regulator blowdown 185	02250146-046	(I)	1
6	connector, 3/8 tube x 1/4npt	02250148-188		1
7	elbow, 1/4" tube x 1/4" npt	250018-430		1
8	tee, pipe 150# plt 1/4	866815-010		1
9	bushing, red pltd 1/4 x 1/8	867100-005		1
10	nipple, pipe-hx pltd 1/4 x 1/4	868504-025		1

(I) For maintenance on regulator blowdown manifold, order repair kit no. 02250147-737.

NOTE: Reference – sub-assembly number 02250166-244.

7.9 REGULATOR/BLOWDOWN VALVE - 300HH AND 375H

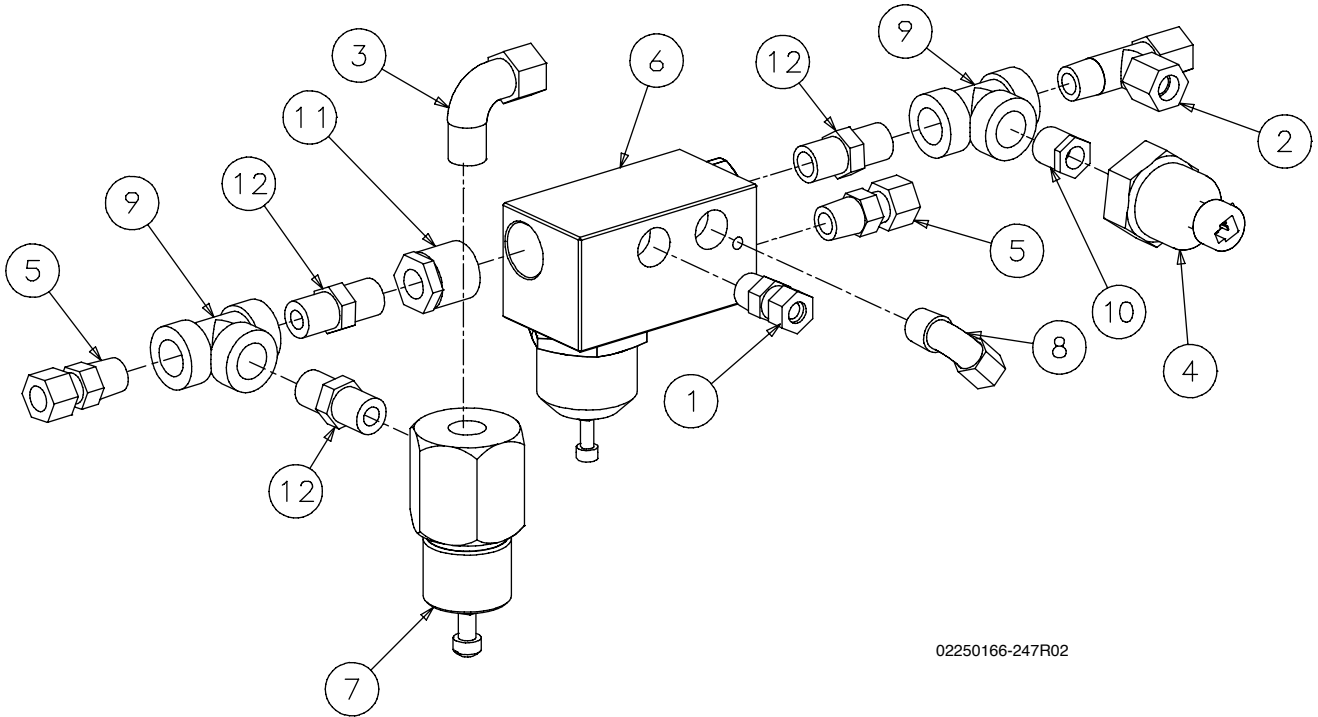

02250166-247R02

7.9 REGULATOR/BLOWDOWN VALVE - 300HH AND 375H (CONTINUED)

Key	Description	Part Number	Note	Quantity
1	connector, 5/16" tube x 1/4" npt	02250081-219		1
2	tee, m run 3/8" tube x 1/4" npt	02250099-615		1
3	elbow, 90 3/8" tube x 1/4" npt m	02250099-626		1
4	transducer, pressure 0-100psi 5volt n4	02250140-194		1
5	connector, 3/8 tube x 1/4npt	02250148-188		2
6	manifold, press reg/bd 150psi 185h	02250151-201	(I)	1
7	valve, pressure regulator	250017-280	(II)	1
8	elbow, 1/4" tube x 1/4" npt	250018-430		1
9	tee, pipe 150# plt 1/4	866815-010		2
10	bushing, red pltd 1/4 x 1/8	867100-005		1
11	bushing, red pltd 1/2 x 1/4	867102-010		1
12	nipple, pipe-hx pltd 1/4 x 1/4	868504-025		3

(I) For maintenance on regulator blowdown manifold, order repair kit no. 02250147-737.

(II) For maintenance on pressure regulator valve, order repair kit no. 250019-453.

NOTE: Reference – sub-assembly number 02250166-245.

7.10 CONTROL PARTS ORIFICE - 300HH AND 375H

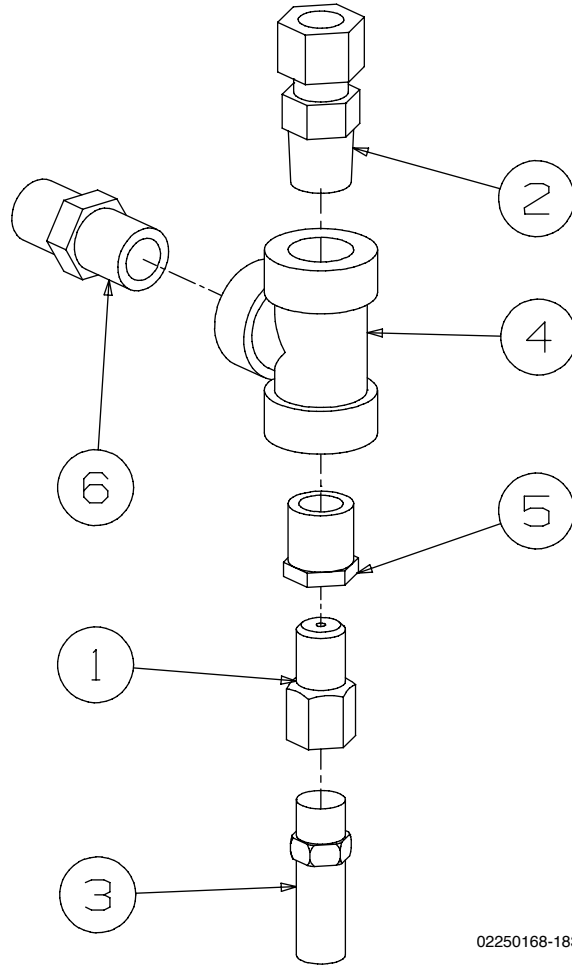

02250168-183R00

7.10 CONTROL PARTS ORIFICE - 300HH AND 375H (CONTINUED)

Key	Description	Part Number	Note	Quantity
1	orifice, ctl .078 1/8 fnpt x 1/8 mnpt	02250069-264		1
2	connector, 3/8 tube x 1/4npt	02250148-188		1
3	silencer, air ejection 1/8" npt-male thread	248755		1
4	tee, pipe 150# plt 1/4	866815-010		1
5	bushing, red pltd 1/4 x 1/8	867100-005		1
6	nipple, pipe-hx pltd 1/4 x 1/4	868504-025		1

7.11 SERVICE VALVES

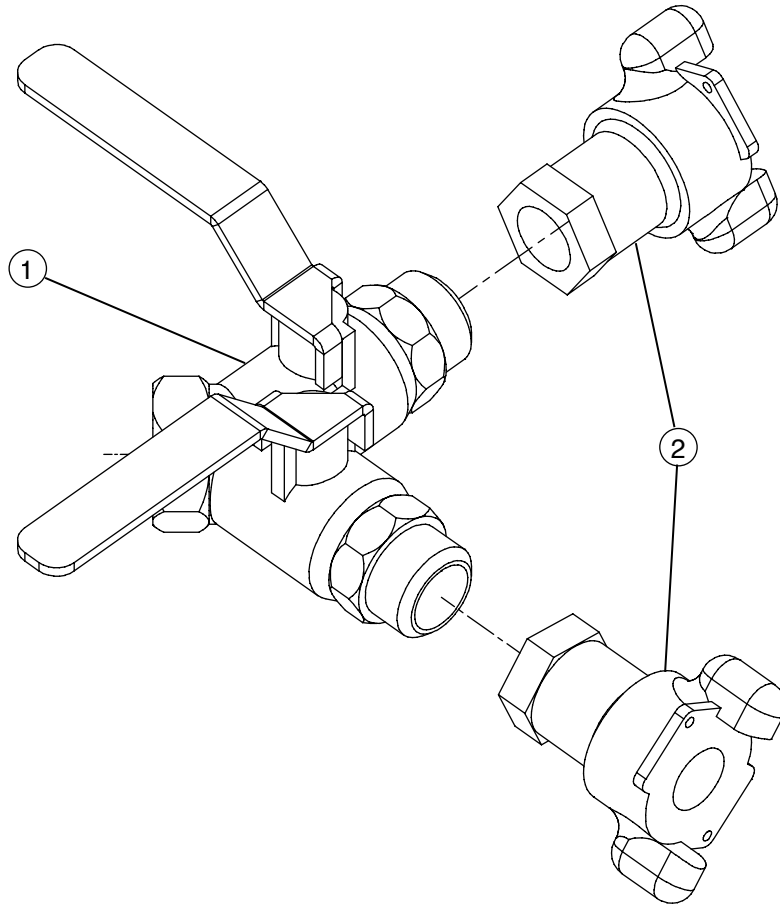

02250118-602R02

7.11 SERVICE VALVES (CONTINUED)

Key	Description	Part Number	Note	Quantity
1	valve, double ball 3/4" x 1"	250019-916		1
2	coupling, 3/4" female npt	040383		2

7.12 OPTIONAL AFTERCOOLER/FILTER AND PARTS

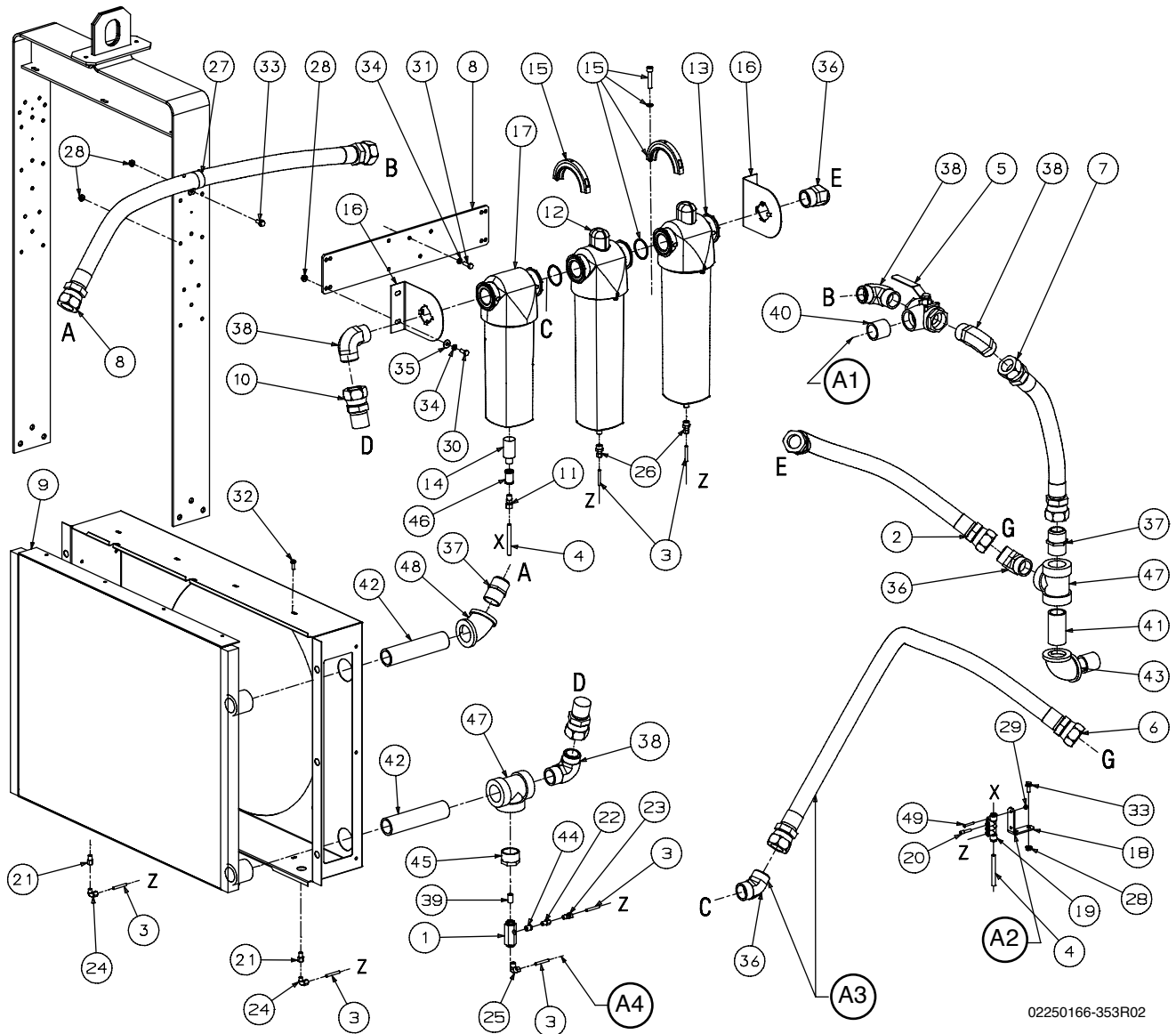

02250166-353R02

7.12 OPTIONAL AFTERCOOLER/FILTER AND PARTS (CONTINUED)

Key	Description	Part Number	Note	Quantity
1	valve, blowdown 1/4 npt hi prs	02250049-634		1
2	hose, medium pressure 250psi 1.5" x 38" fji	02250051-446		1
3	tube, nyl .25 od x .040w blk (ft)	02250054-861		39
4	tube, nylon .375" od x .050w black (ft)	02250099-630		6
5	valve, ball 3-wat 1-1/2 fnpt	02250118-872		1
6	hose, aftr clr to sep 375 48"	02250119-082		2
7	hose, air 3-way to manifold 375	02250119-083		1
8	support, after cooler filters	02250142-733		1
9	cooler, air to air 300h-375	02250142-958		1
10	hose, mpress 1-1/2 x 25"	02250119-083		1
11	connector, 3/8 tube x 1/4npt	02250148-188		1
12	filter, scf-465n 1 1/4" npt w/auto drains	02250153-038		1
13	filter, sch-465n 1 1/4" npt w/auto drains	02250153-062		1
14	kit, auto drain sc filters	02250153-280		1
15	kit, sc head clmp 340-700	02250153-286		2
16	kit, sc mounting bracket 340-700	02250154-587		2
17	separator, water scws-740n 1 1/2" l/ad	02250166-741		1
18	support, manf ac drains 375 t3	02250167-724		1
19	manifold, tubing push-in 1/4 & 3/8	02250167-725		1
20	plug, 1/4" push-in plastic	02250167-726		4
21	orifice, ctl .031 1/8 fnpt x 1/8 mnpt	025690		2
22	orifice, ctl .094 1/8 fnpt x 1/8 mnpt	250014-060		1
23	conn, 1/4" tube x 1/8" npt	250018-427		1
24	elbow, 90 1/4" tube x 1/8" npt	250018-429		2
25	elbow, 90 1/4t pls x 1/4 npt m	250018-430		1
26	connector, straight 1/4t plsx 1/4npt f	250041-084		2
27	clamp, hose 1 3/8" i.d.	408300-008		1
28	nut, hex f pltd 5/16-18	825305-283		5
29	nut, hex locking #10-24	825502-083		2
30	capscrew, hex gr5 5/16-18 x 3/4	829105-075		1
31	capscrew, hex gr5 5/16-18 x 1	829105-100		1
32	screw, hex ser washer 1/4-20 x 3/4	829704-075		8
33	screw, hex ser washer 5/16-18 x 3/4	829705-075		3
34	washer, spr lock reg pltd 5/16	837805-078		2
35	washer, pl-b reg pltd 5/16	838205-071		1
36	elbow, 37fl 45m 1 1/2 x 1 1/2	860024-150		3
37	connector, 37 fl/mpt pltd 1 1/2 x 1 1/2	860124-150		2
38	elbow, 37fl 90m 1 1/2 x 1 1/2	860224-150		4
39	nipple, pipe-xs plt 1/4 x cl	866404-000		1
40	nipple, pipe-xs plt 1 1/2 x cl	866424-000		2
41	nipple, pipe-xs plt 1 1/2 x 3 1/2	866424-035		1
42	nipple, pipe-xs plt 1 1/2 x 8	866424-080		2
43	elbow, pipe 90 deg 300# plt 1 1/2"	867030-060		1

7.12 OPTIONAL AFTERCOOLER/FILTER AND PARTS (CONTINUED)

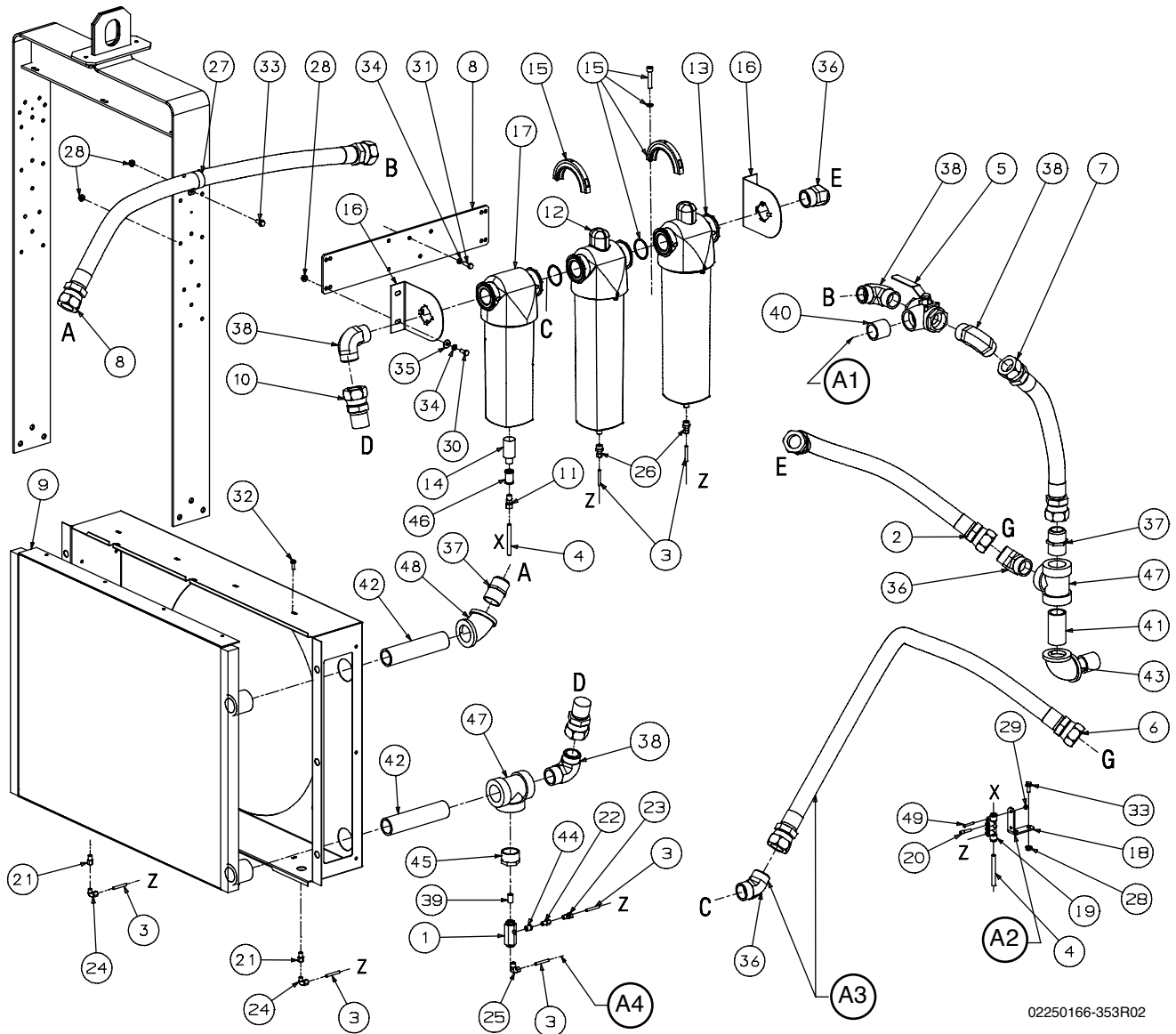

02250166-353R02

7.12 OPTIONAL AFTERCOOLER/FILTER AND PARTS (CONTINUED)

Key	Description	Part Number	Note	Quantity
44	bushing, red pltd 1/4 x 1/8	867100-005		1
45	bushing, red pltd 1 1/2 x 1/4	867106-010		1
46	coupling, pipe 1/4 300# plt	867430-010		1
47	tee, pipe pltd 1 1/2	868430-060		2
48	elbow, pipe 45 deg 300# plt 1 1/2"	869430-060		1
49	screw, rnd phillips 10-24 x 1 1/4"	876002-125		2
A1	To min. pressure valve			
A2	Mounted on frame near receiver			
A3	Used with aftercooler less filters option			
A4	From tee fitting below inlet valve			

7.13 ELECTRICAL PARTS

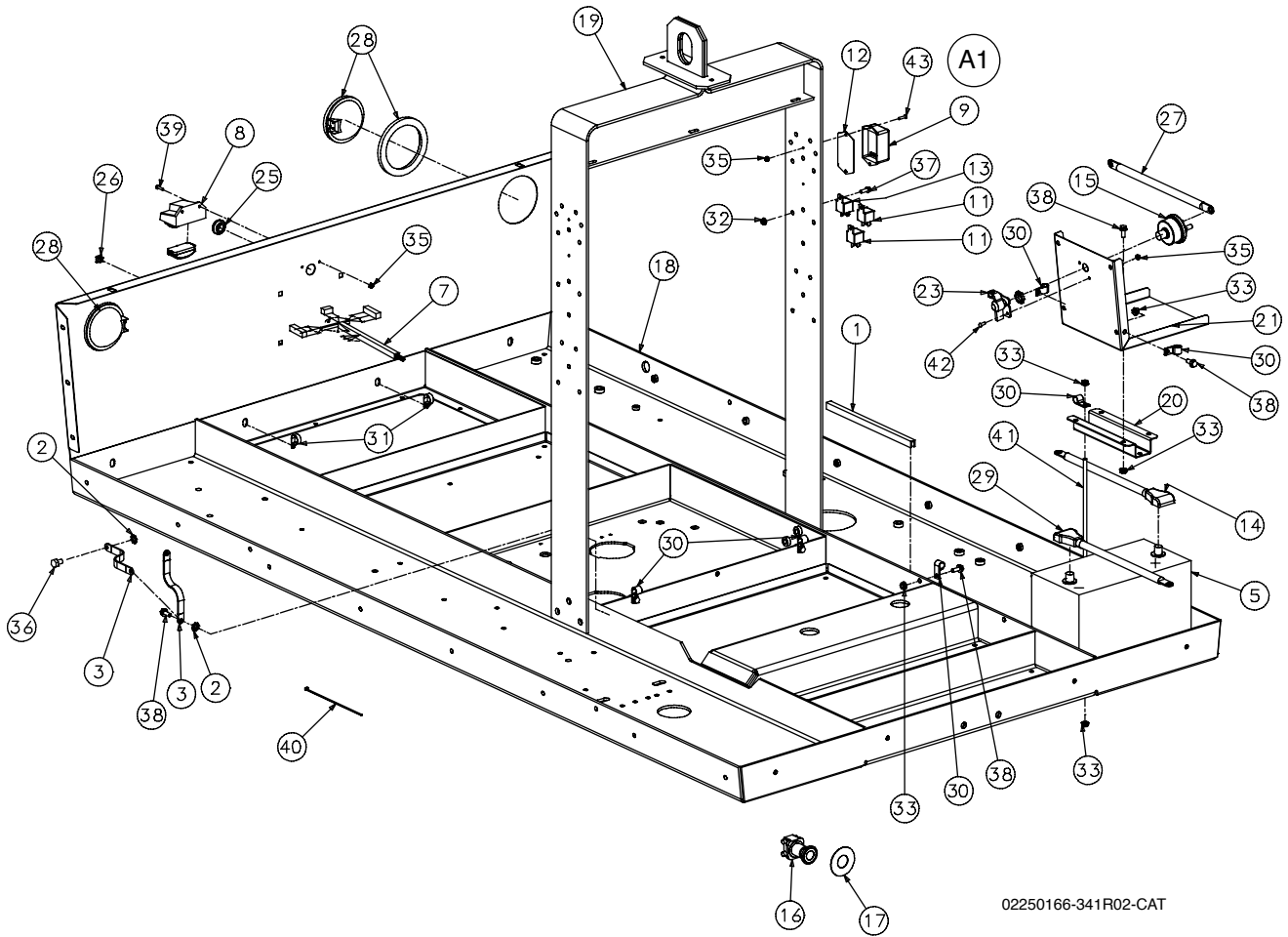

7.13 ELECTRICAL PARTS (CONTINUED)

Key	Description	Part Number	Note	Quantity
1	channel, extruded rubber "u" .25" w (ft)	02250086-448		2
2	washer, external serrated m10	02250092-169		1
3	cable, ground 4-gauge strap	02250101-258		1
5	battery, grp 31 hi cap taper post	02250114-276		1
6	lamp, license plate std	02250119-658		1
7	harness, 6-wire lites 375	02250119-673		1
8	bracket, license plate lamp	02250119-678		1
9	module, electronic speed control	02250138-678		1
11	relay, 12-volt 40-amp 1no/1nc	02250141-092		2
12	gasket, e.s.c. jd tier ii	02250141-766		1
13	relay, 12-volt 50-amp 1no/1nc	02250144-353		1
15	switch, battery disconnect 6-36v; 175 amps cont	02250160-837		1
16	switch, e-stop hd push-pull red	02250163-818		1
17	plate, cover large portable e-stop	02250163-821		1
18	frame, assy 375-600 q t3	02250164-386		1
19	bail, lifting 375 t3	02250164-550		1
20	channel, batt hold dwn 375-600t3	02250164-692		1
21	panel, batt cvr/baff 375-600t3	02250164-693		1
22	panel, frm rear 375-600 t3	02250164-958	(I)	1
23	lock, batt disconnect switch	02250165-472		1
25	grommet, rubber 1" hole	040162		1
26	nut, plastic square license plate	250006-076		4
27	cable, battery 1/o x 50"	250018-235		1
28	lamp, tail/turn/stop (shock mtg)	250028-415		2
29	cable, battery 18" lg black	250029-839		1
30	clamp, hose 9/16" id	408300-001		5
31	clamp, hose 7/8" i.d.	408300-004		2
32	nut, hex f pltd 1/4-20	825304-236		3
33	nut, hex f pltd 5/16-18	825305-283		12
35	nut, hex locking #10-24	825502-083		5
37	screw, hex ser washer 1/4-20 x 3/4	829704-075		3
38	screw, hex ser washer 5/16-18 x 3/4	829705-075		9
39	screw, mach-rd hd #10-24 x 3/4	831602-075		2
40	wrap, tie nylon tf4-8	843200-025		4

7.13 ELECTRICAL PARTS (CONTINUED)

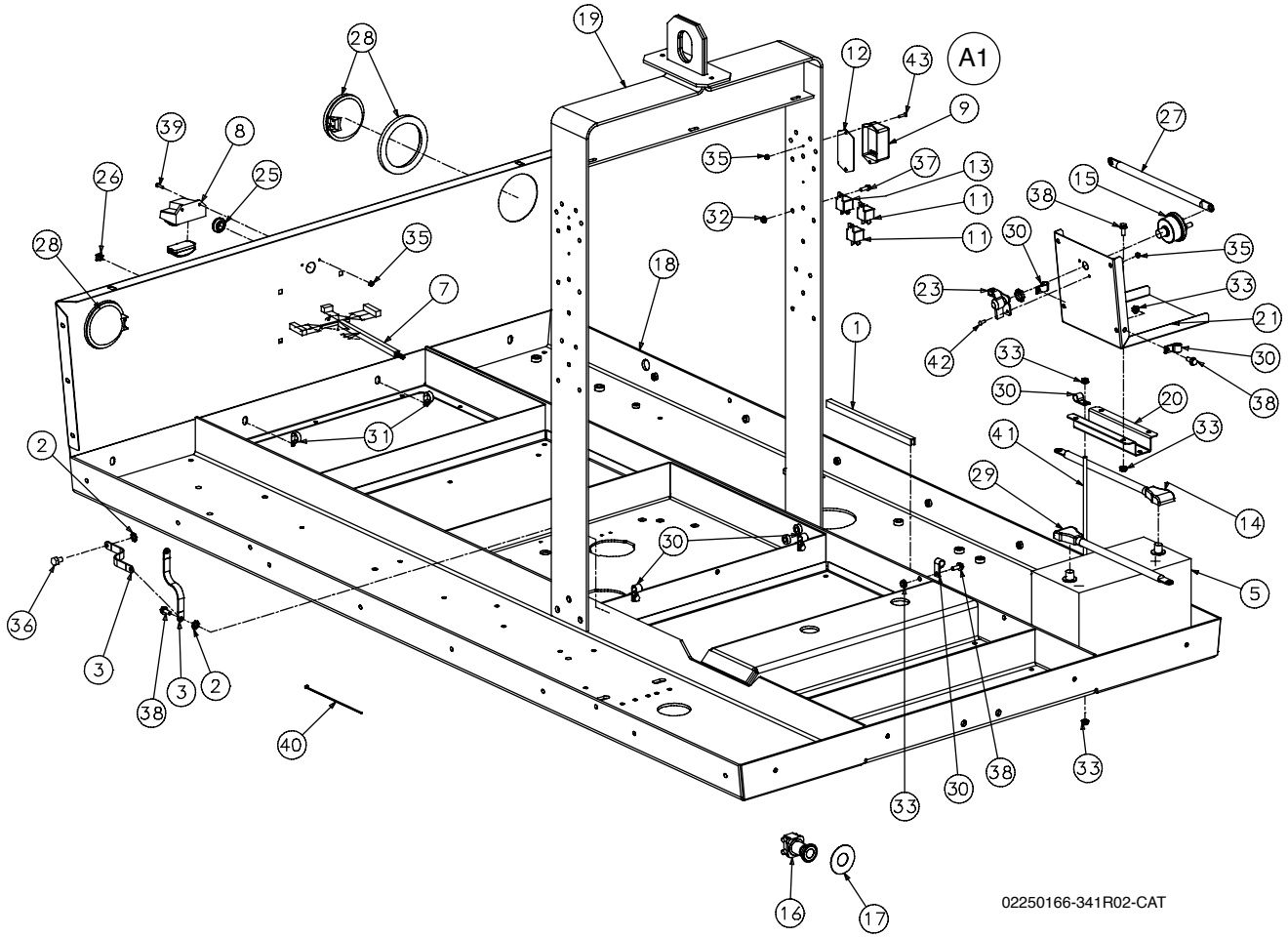

02250166-341R02-CAT

7.13 ELECTRICAL PARTS (CONTINUED)

Key	Description	Part Number	Note	Quantity
41	rod, threaded 5/16 x 10" lg	843505-100		2
42	screw, rnd phillips 10-24 x 1/2"	876002-050		1
43	screw, rnd phillips 10-24 x 3/4"	876002-075		2
A1	Relays and speed control supplied with panel harness			

(I) For color variations consult factory.

7.14 INSTRUMENT PANEL & PARTS

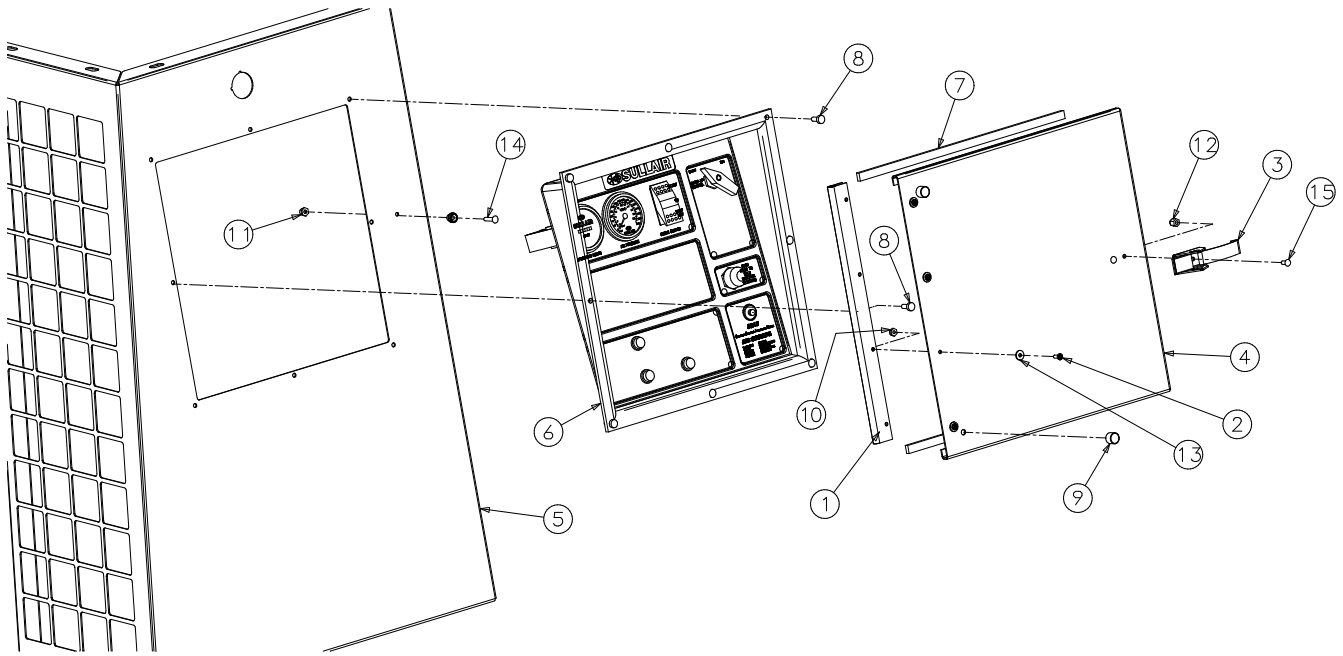

02250166-348R00

7.14 INSTRUMENT PANEL & PARTS (CONTINUED)

Key	Description	Part Number	Note	Quantity
1	hinge, instrument panel door 185q-8f	02250103-623		1
2	screw, phil pan hd #6-32 x 3/8	02250112-009		4
3	latch, locking instrument panel	02250125-511		1
4	door, instrument panel 185 60hp	02250138-181		1
5	panel, canopy frt lh 375 t3	02250164-807	(I)	1
6	panel, instr 375-425 cat t3 std	02250165-421*		1
7	weatherstrip, 3/16 x 3/8 ft	250022-436		3
8	screw, mach phill #10-24 x 1/2	250025-692		8
9	bumper, rubber 1/2 dia	250035-095		2
10	nut, hex locking #6-32	825500-102		4
11	nut, hex locking #8-32	825501-070		1
12	nut, acorn pltd #8-32	825615-002		2
13	washer, pl-b reg pltd #6	838200-045		4
14	screw, flt phillips 8-32 x 3/4"	875901-075		1
15	screw, rnd phillips 8-32 x 3/8"	876001-038		2

* P/N 02250165-422 for 300HH and 375H

(I) For color variations consult factory.

7.14 INSTRUMENT PANEL & PARTS (CONTINUED)

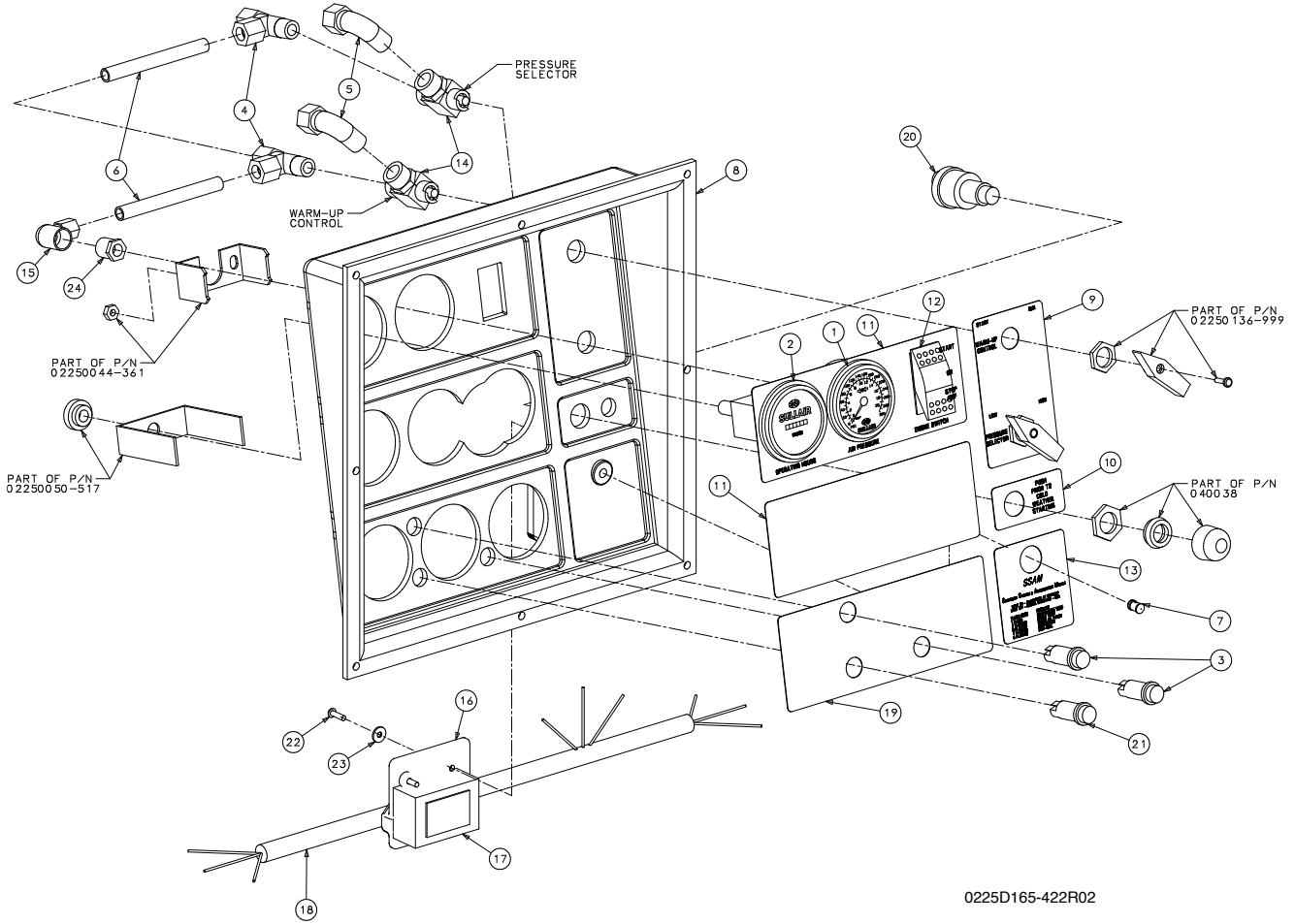

7.14 INSTRUMENT PANEL & PARTS (CONTINUED)

Key	Description	Part Number	Note	Quantity
1	gauge, pressure air 0-300 2"	02250044-361		1
2	hour-meter, 12-24vdc 10000hr 2"	02250050-517		1
3	lamp, warning indicator - amber	02250054-392		2
4	tee, m run 3/8" tube x 1/4" npt	02250099-615		2
5	elbow, 90 3/8" tube x 1/4" npt m	02250099-626		2
6	tube, nylon .375" od x .050w black (ft)	02250099-630		2
7	lense, cliplite led	02250129-189		1
8	panel, instrument plastic ssam	02250129-190		1
9	decal, dual pressure 185-375 ssam	02250130-630	(I)	1
10	decal, starting aid 185-375 cat	02250130-631		1
11	decal, group std panel (ssam)	02250131-485		1
12	switch, engine ignition 12-volt	02250132-883		1
13	decal, ssam low fuel option	02250133-620		1
14	valve, ball 2-way 1/4" npt	02250136-999		2
15	elbow, 90 f 3/8" tube x 1/4" npt	02250137-033		1
16	cover, access ssam molded abs	02250137-265		1
17	cont, ssam 185-60 hp	02250139-296		1
18	harness, eng & compr 375 cat t3	02250165-172	(II)	1
19	decal, warn lites 375 t3 pnls	02250165-425		1
20	switch, starter push-buttons	040038		1
21	lamp, warning indicator - red	250003-117		1
22	screw, tc-f rd hd #6-32 x 1/2	835700-050		2
23	washer, pl-b reg pltd #6	838200-045		2
24	bushing, red pltd 1/4 x 1/8	867100-005		1
A1	Pressure selector			
A2	Warm-up control			
A3	Part of P/N 02250044-361			
A4	Part of P/N 02250050-361			
A5	Reference wiring diagram P/N 02250165-163			
A6	Part of P/N 02250136-999			
A7	Part of P/N 040038			

(I) 300HH and 375H models only

(II) Use P/N 02250141-092 for replacement of starter and shutdown relays. Use P/N 02250144-353 for replacement of glow plug relay.

REFERENCE WIRING DIAGRAM P/N 02250165-163

7.15 FUEL TANK & CONNECTIONS

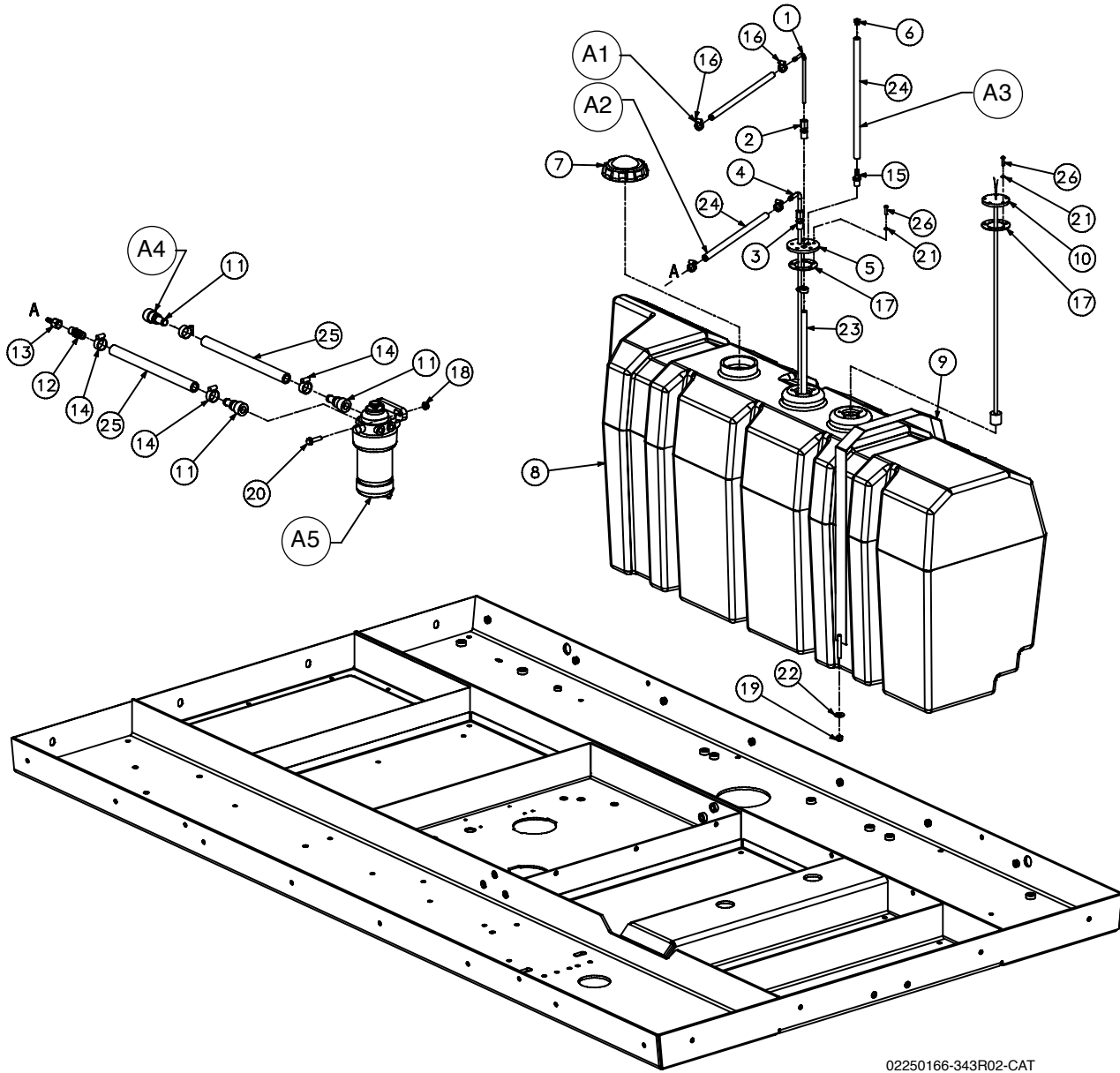

02250166-343R02-CAT

7.15 FUEL TANK & CONNECTIONS (CONTINUED)

Key	Description	Part Number	Note	Quantity
1	tube, fuel return 1/4" jd 185q	02250102-573		1
2	connector, tube oil return 1/4 x 1/4	02250108-700		1
3	connector, tube oil return 5/16x1/4	02250118-809		1
4	tube, fuel pick-up 185dpq 60hp	02250139-885		1
5	adapter, fuel pickup 185 60hp	02250152-163		1
6	ventilator, fuel tank	02250162-229		1
7	cap, fuel fill buttress thread	02250162-230		1
8	tank, fuel plstc 56 gal 375	02250164-384		1
9	strap, fuel tank mtg 375-600 t3	02250165-197		2
10	switch, float fuel sht dwn 22.25 lg	02250167-999		1
11	connector, quick dis 5/8 id hose	02250169-488		3
12	fitting, hose barb 3/8 npt x 5/8 hose id	02250169-493		1
13	fitting, hose barb 3/8 npt x 5/16 hose id	02250171-164		1
14	clamp, hose 13/16" to 1-1/2"	040513		4
15	connector, hose 5/16" hose x 1/4" npt	043258		1
16	clamp, hose 3/8"	047235		5
17	gasket, fuel gauge neoprene	250004-752		2
18	nut, hex f pltd 5/16-18	825305-283		2
19	nut, hex locking 5/16-18	825505-166		4
20	screw, hex ser washer 5/16-8 x 1 1/4	829705-125		2
21	washer, spr lock reg pltd #10	837802-047		10
22	washer, pl-b reg pltd 5/16	838205-071		4
23	hose, fuel line 1/4 (ft)	842315-025		7
24	hose, fuel line 5/16 (ft)	842315-031		4
25	hose, fuel line 5/8 (ft)	842315-062		6
26	screw, rnd phillips 10-24 x 3/4"	876002-075		10
A1	From engine fuel return fitting.			
A2	To engine fuel inlet fitting (3" long for CAT).			
A3	Cut to 5" length and secure to fuel return hose with cable tie.			
A4	To engine fuel inlet fitting.			
A5	Caterpillar supplied filter mounted at end of air inlet filter bracket.			

7.16 FRAME, AXLE & PARTS AND AXLE ASSEMBLY

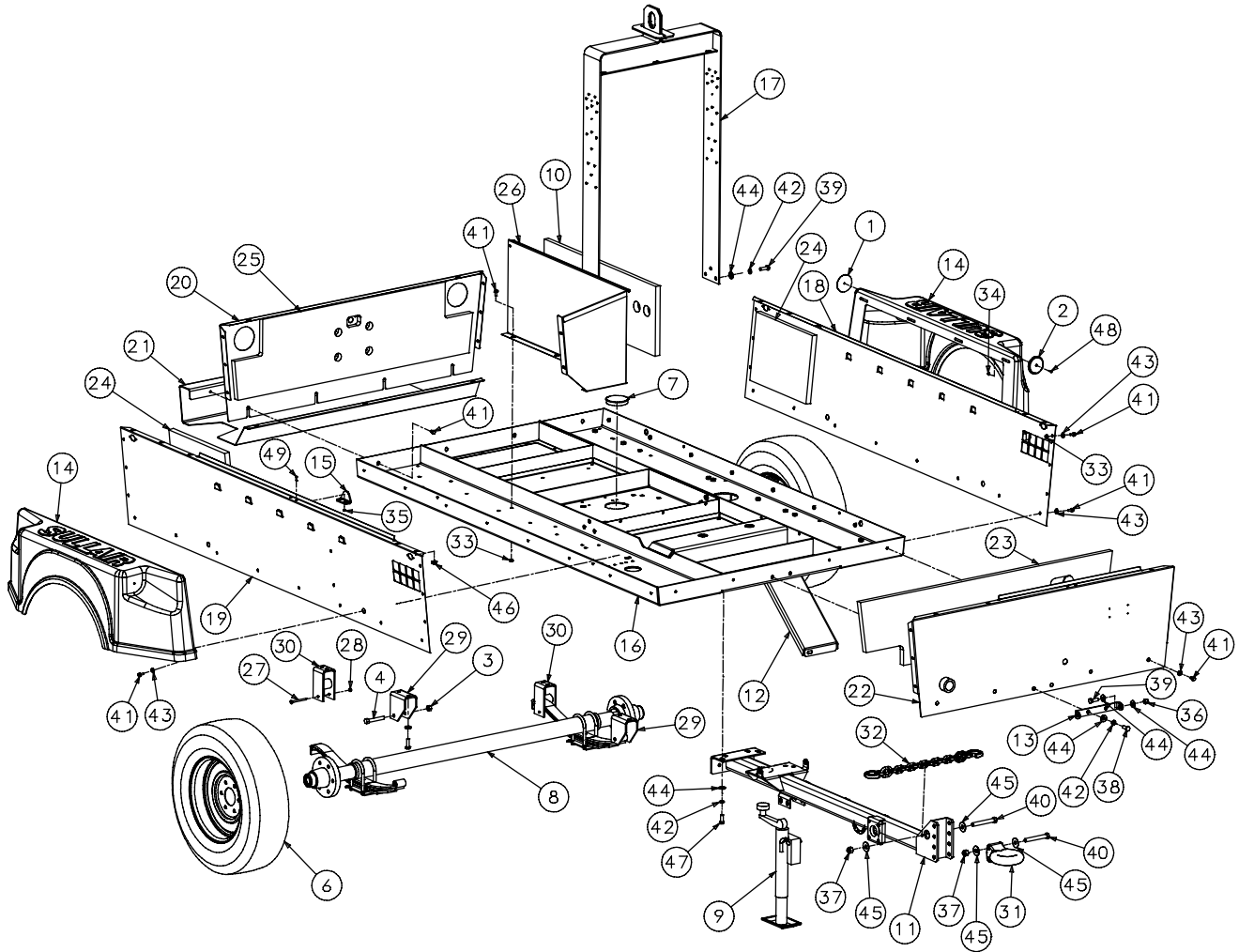

02250166-334R02

7.16 FRAME, AXLE & PARTS AND AXLE ASSEMBLY (CONTINUED)

Key	Description	Part Number	Note	Quantity
1	reflector, red 3" truck-lite	02250052-701		2
2	reflector, yellow 3" truck-lite	02250052-702		2
3	nut, shackle (dexter 6-7)	02250058-263		2
4	bolt, shackle (dexter 7-17)	02250058-267		2
5	washer, flat hardened 1/2"	02250064-266		8
6	tire, assembly h78-15 st d	02250100-518		2
7	plug, 4" round black plastic	02250106-068		2
8	axle, assembly 300h-425 dpq std	02250116-323		1
9	jack, hd w/pad 185-425 std	02250116-794		1
10	panel, acoustic toolbox 375dpq	02250132-877		1
11	drawbar, std pivot 185dpq	02250133-864		1
12	support, shipping 185 pivot drbar	02250133-984		1
13	support, dr-bar swivel 185q	02250141-183		1
14	fender, 15" wheel 185h-260dpq	02250146-111		2
15	striker, latch frt-bk-sides 185h-260	02250149-684		3
16	frame, assy 375-600 q t3	02250164-386		1
17	bail, lifting 375 t3	02250164-550		1
18	panel, frm rh 375-600 t3	02250164-695	(I)	1
19	panel, frm lh 375-600 t3	02250164-698	(I)	1
20	panel, frm rear 375-600 t3	02250164-701	(I)	1
21	panel, bumper 375-600 t3	02250164-707	(I)	1
22	panel, frm frt 375-600 t3	02250164-704	(I)	1
23	panel, acoustic frm frt 375 t3	02250165-531		1
24	panel, acoustic frm r&l rear 375 t3	02250165-532		2
25	panel, acoustic frm rear 375 t3	02250165-533		1
26	panel, toolbox 375-600 t3	02250165-538		1
27	bolt, keeper (dexter 07-007-00)	040116		2
28	nut, keeper (dexter 06-011-00)	040117		2
29	hanger, front mount 375dpq	045194		2
30	hanger, rear slipper dexter #030-028-03	045195		2
31	eye, 3" lunette demountable -	250002-221		1
32	chain, 3/8" x 71" w/2 hks pltd	250018-492		1
33	nut, hex f pltd 5/16-18	825305-283		18
34	nut, hex locking #8-32	825501-070		4
35	nut, hex locking #10-24	825502-083		6
36	nut, hex locking 1/2-13	825508-262		2
37	nut, hex locking 5/8-11	825510-329		3
38	capscrew, hex gr5 1/2-13 x 1 1/4	829108-125		3
39	capscrew, hex gr5 1/2-13 x 1 1/2	829108-150		14
40	capscrew, hex gr5 5/8-11 x 4 3/4	829110-475		3
41	screw, hex ser washer 5/16-18 x 3/4	829705-075		50
42	washer, spr lock reg pltd 1/2	837808-125		25
43	washer, pl-b reg pltd 5/16	838205-071		36

7.16 FRAME, AXLE & PARTS AND AXLE ASSEMBLY (CONTINUED)

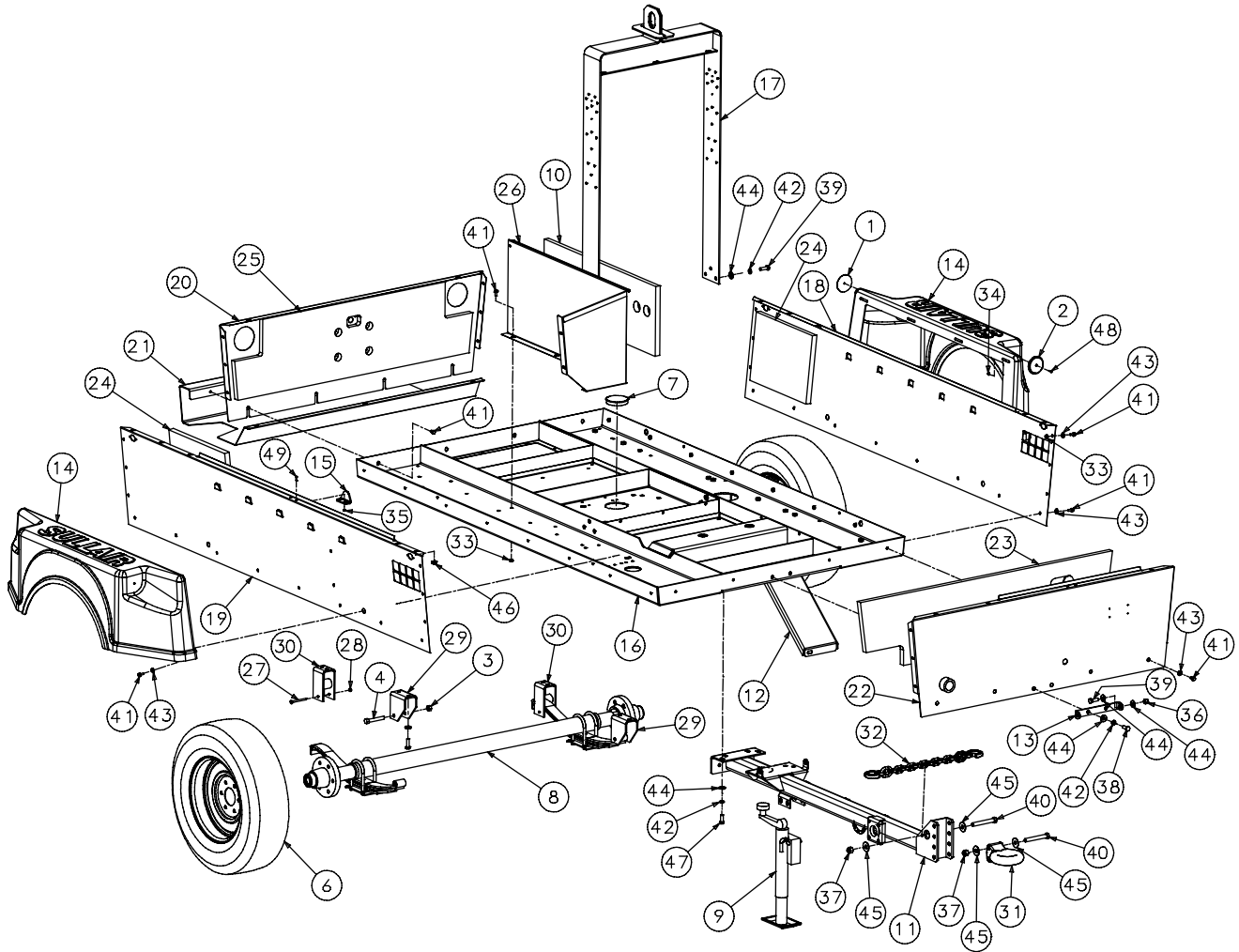

02250166-334R02

7.16 FRAME, AXLE & PARTS AND AXLE ASSEMBLY (CONTINUED)

Key	Description	Part Number	Note	Quantity
44	washer, pl-b reg pltd 1/2	838208-112		17
45	washer, pl-b reg pltd 5/8	838210-112		6
46	nut, retainer 5/16-18 .092	861405-092		15
47	capscrew, hex gr5 1/2-13 x 1 1/4 plt	875608-125		8
48	screw, flt phillips 8-32 x 3/4"	875901-075		4
49	screw, rnd phillips 10-24 x 3/4"	876002-075		6

(I) For color variations consult factory.

7.17 AXLE ASSEMBLY

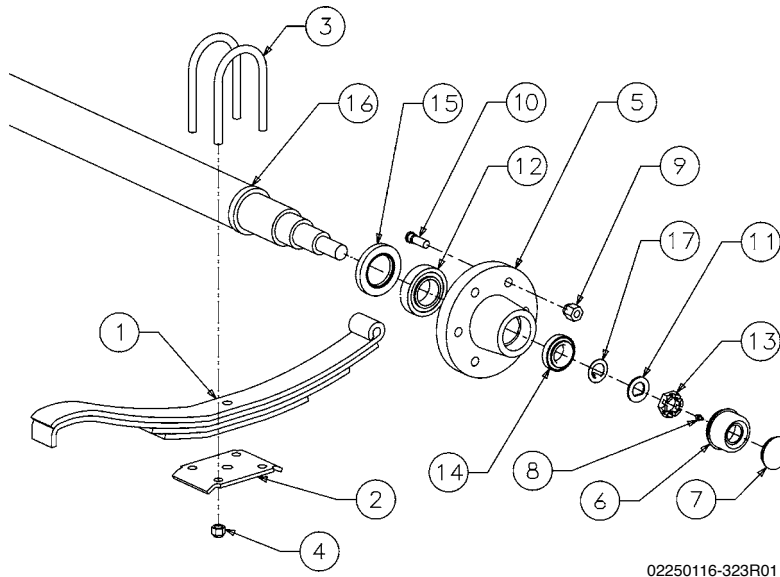

02250116-323R01

7.17 AXLE ASSEMBLY (CONTINUED)

Key	Description	Part Number	Note	Quantity
1	spring, leaf 2500# 375dpq	250010-112		2
2	plate, tie dexter# 12-2	045197		2
3	u-bolt, axle spring mtg. 3"	242486		4
4	nut, hex 1/2-20 plated	047881		8
5	hub, 6 on 5-1/2" bolt center	250025-527		2
6	cap, grease axle assy dexter#21-042	250040-788		2
7	plug, rubber axle assy ez-lube	–		2
8	fitting, grease-str 1/4" npt	861000-025		2
9	nut, wheel 1/2-20 plated	250023-470		12
10	stud, wheel hub axle assy	250023-468		12
11	washer, spindle dexter#5-023	047874		2
12	bearing, inner dexter#31-30	040118		2
13	nut, spindle dexter#6-001	047875		2
14	bearing, outer dexter#31-32	040119		2
15	seal, oil axle assy dexter# 10-10	250040-787		2
16	beam, axle 49.92sc 67.5hf	–		1
17	washer, tang axle assembly	250040-784		1

7.18 CANOPY, ACOUSTICAL PANELS & PARTS

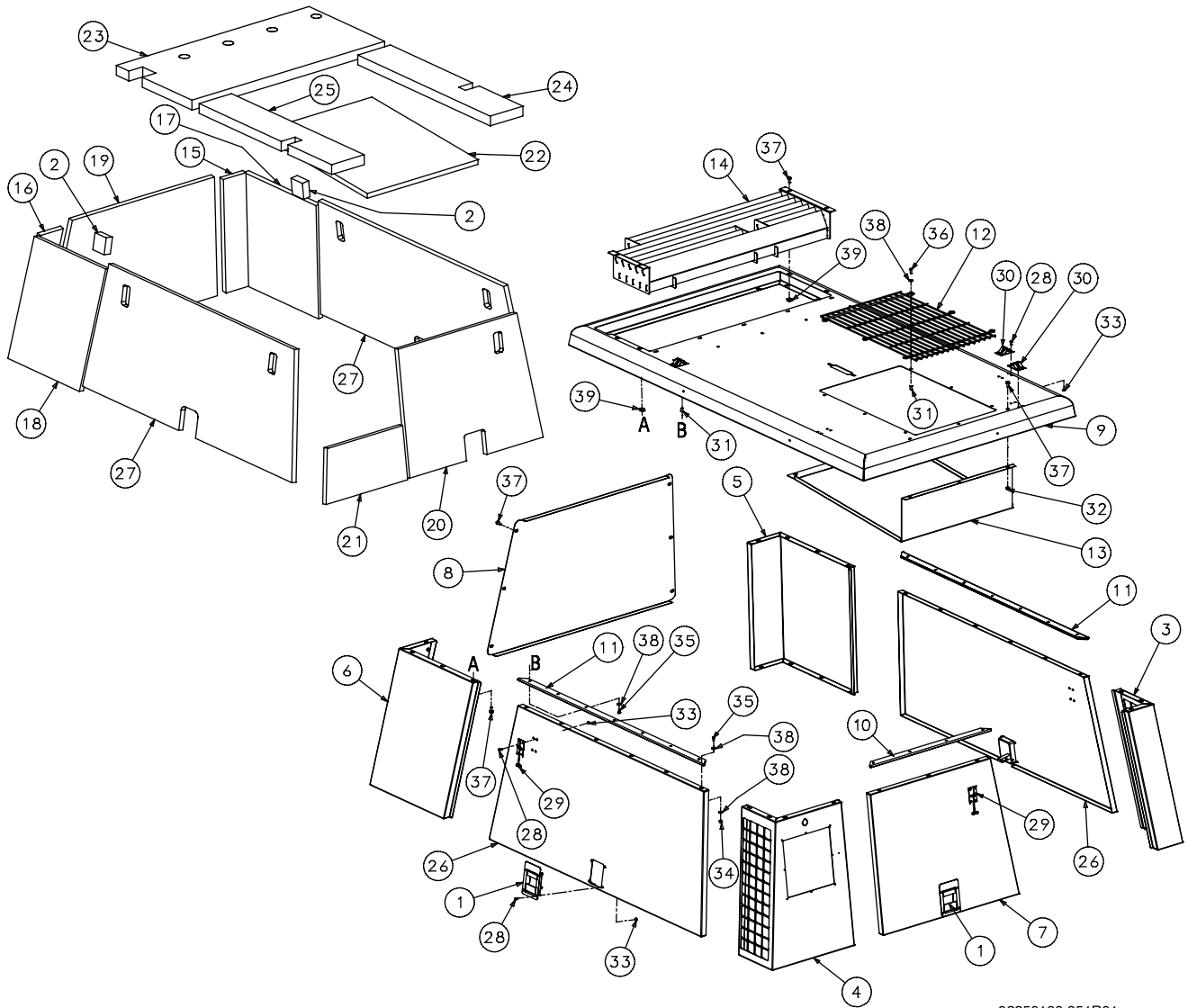

02250166-351R01

7.18 CANOPY, ACOUSTICAL PANELS & PARTS (CONTINUED)

Key	Description	Part Number	Note	Quantity
1	catch, pivot slam pad lck blk -	02250107-837		3
2	insulation, clr baff fill 185h	02250147-126		2
3	panel, can frt rh 375 t3	02250164-802	(I)	1
4	panel, can frt lh 375 t3	02250164-807	(I)	1
5	panel, can rear rh 375t3	02250164-812	(I)	1
6	panel, can rr lh 375 t3	02250164-817	(I)	1
7	panel, door can frt 375 t3	02250164-836	(I)	1
8	panel, canopy rear 375 t3	02250164-859	(I)	1
9	panel, roof 375-600 t3	02250164-864	(I)	1
10	hinge, canopy door frt 375 t3	02250164-878		1
11	hinge, can door sides 375 t3	02250164-879		2
12	grille, canopy roof inl 375 t3	02250164-880		1
13	baffle, can roof 375 t3	02250164-881		1
14	louver, air exhaust 375-600 t3	02250164-882		1
15	panel, acoustic can rr rh 375 t3	02250165-522		1
16	panel, acoustic can rr lh 375 t3	02250165-523		1
17	panel, acoustic can rr side rh 375 t3	02250165-524		1
18	panel, acoustic can rr side lh 375 t3	02250165-525		1
19	panel, acoustic rear acc 375 t3	02250165-526		1
20	panel, acoustic can door frt 375 t3	02250165-529		1
21	panel, acoustic can frt 375 t3	02250165-530		1
22	panel, acoustic roof baff 375 t3	02250165-534		1
23	panel, acoustic roof rear 375 t3	02250165-535		1
24	panel, acoustic roof frt rh 375 t3	02250165-536		1
25	panel, acoustic roof frt lh 375 t3	02250165-537		1
26	tabulation, door canopy l&r 375-425 t3	02250167-515		2
27	panel, acoustic can dr r&l 375-425 t3	02250167-545		2
28	screw, mach phill #10-24 x 1/2	250025-692		36
29	hook, door latch male ss	250033-828		3
30	catch, door latch female ss	250033-829		3
31	insert, 1/4-20 blind	250034-538		24
32	nut, hex f pltd 5/16-18	825305-283		6
33	nut, hex locking #10-24	825502-083		36
34	nut, hex locking 1/4-20	825504-145		15
35	capscrew, hex gr5 1/4-20 x 1/2	829104-050		33
36	capscrew, hex gr5 1/4-20 x 3/4	829104-075		6
37	screw, hex ser washer 5/16-18 x 3/4	829705-075		31
38	washer, pl-b reg pltd 1/4	838204-071		54
39	nut, retainer 5/16-18 .092	861405-092		19

(I) For color variations consult factory.

7.19 DECALS

2

**NEED AN AIR TOOL
FOR THIS TOOL BOX?**

CALL 1-800-SULLAIR, EXT. 5271

 **SULLAIR**
www.sullair.com

02250140-925

3

INSTALLATION OF DRAWBAR

WARNING! SUPPORT FRONT END OF MACHINE WITH STURDY JACK STAND(S) SO DRAWBAR IN THE UP POSITION IS 2 TO 3 INCHES OFF THE GROUND. DO THIS BEFORE REMOVING THE DRAWBAR SHIPPING SUPPORT.

- 1) REMOVE SHIPPING SUPPORT FROM THE COMPRESSOR AND DRAWBAR.
- 2) SLIGHTLY LOOSEN THE DRAWBAR PIVOT BOLTS. DO NOT REMOVE THEM.
- 3) CAREFULLY SWING THE DRAWBAR TO IT'S DOWN POSITION. INSTALL WITH PROVIDED HARDWARE (8 1/2-13 X 1-1/4 GRADE 5 SELF-LOCKING CAPSCREWS, 1/2" NORD LOCK WASHERS AND 1/2" FLAT WASHERS) THROUGH THE DRAWBAR MOUNTING PLATES. TORQUE ALL BOLTS TO 77 FT-LBS. NOTE: THE BOLTS AND FRAME NUTS TO BE CLEAN AND FREE OF OIL. RETIGHTEN THE DRAWBAR PIVOT BOLTS.
- 4) REMOVE SHRINK WRAP FROM JACK STAND AND CHAINS. PUT JACK IN DOWN POSITION AND REMOVE YOUR MACHINE SUPPORTS.

02250142-050

4

CAUTION

**DIESEL FUEL ONLY
SHUT ENGINE OFF
BEFORE REFUELING**

040248

1

START - STOP PROCEDURE

(READ ALL STEPS PRIOR TO STARTING THE COMPRESSOR)

TO START:

- 1) CHECK ENGINE OIL, COOLANT, FUEL, AND COMPRESSOR OIL LEVELS. DRAIN WATER FROM THE FUEL-WATER SEPARATOR.
- 2) CLOSE AND LATCH ALL DOORS EXCEPT INSTRUMENT PANEL.
- 3) CLOSE ALL SERVICE VALVES AND TURN THE WARM-UP CONTROL VALVE TO "START" POSITION.
- 4) IF ENGINE IS COLD PUSH "COLD WEATHER STARTING" BUTTON IN FOR 10-30 SECONDS. THEN RELEASE.
- 5) DEPRESS THE RED ENGINE SWITCH ALL THE WAY TO THE START POSITION. HOLD SWITCH UNTIL ENGINE STARTS, THEN RELEASE SWITCH.

NOTE: *DO NOT CRANK ENGINE FOR MORE THAN 15 SECONDS. IF ENGINE DOES NOT START, TURN STARTER SWITCH TO "OFF" POSITION. WAIT 1 MINUTE AND REPEAT STEPS 4 - 5.*

- 6) AFTER 30 SECONDS (SSAM LIGHT WILL GO OFF AFTER 30 SECONDS), TURN WARM-UP CONTROL VALVE TO "RUN" POSITION.
- 7) ON DUAL PRESSURE MACHINES, TURN THE PRESSURE SELECTOR VALVE TO "HIGH" OR "LOW" POSITION.

TO STOP:

- 1) CLOSE ALL SERVICE VALVES. ON DUAL PRESSURE MACHINES TURN SELECTOR VALVE TO "LOW" POSITION. OPERATE AT IDLE FOR 5 MINUTES.
- 2) TURN STARTER SWITCH TO "OFF" POSITION.

EMERGENCY STOP: PRESS EMERGENCY STOP BUTTON ABOVE INSTRUMENT PANEL

02250165-938 REV. 00

SU_0000681

7.19 DECALS (CONTINUED)

Key	Description	Part Number	Note	Quantity
1	decal, operator procedure start stop	02250165-938		1
2	decal, "need an air tool" sml	02250140-925		1
3	decal, drwbr instl 185q pe std	02250142-050	(I)	1
4	decal, diesel fuel	040248		1

(I) OSHA guidelines are superseded by any Federal, State or Local regulations whenever applicable.

7.19 DECALS (CONTINUED)



7



8

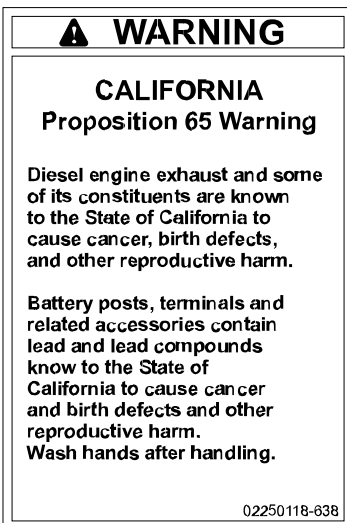

9

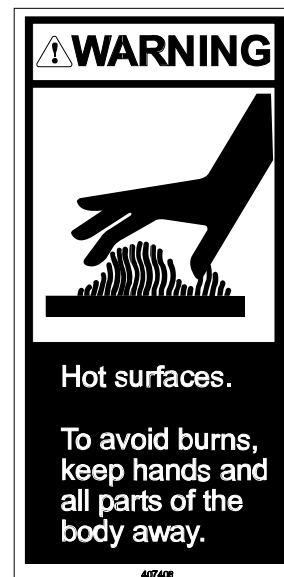

10

SU_0000682

7.19 DECALS (CONTINUED)

Key	Description	Part Number	Note	Quantity
7	decal, warning tongue heavy 100-375	02250077-929	(I)	1
8	decal, warning side door T-latch	02250136-670		3
9	decal, lead warning proposition 65	02250118-638		1
10	sign, warning hot surfaces	407408		3

(I) OSHA guidelines are superseded by any Federal, State or Local regulations whenever applicable.

7.19 DECALS (CONTINUED)



COMPRESSOR NOISE EMISSION CONTROL INFORMATION

SULLAIR.
SULLAIR CORPORATION
MICHIGAN CITY, INDIANA U.S.A.

THIS COMPRESSOR CONFORMS TO U.S. E.P.A. REGULATIONS FOR NOISE EMISSIONS APPLICABLE TO PORTABLE AIR COMPRESSORS. THE FOLLOWING ACTS OR THE CAUSING THEREOF BY ANY PERSON ARE PROHIBITED BY THE NOISE CONTROL ACT OF 1972:

(A) THE REMOVAL OR RENDERING INOPERATIVE OTHER THAN FOR THE PURPOSE OF MAINTENANCE, REPAIR, OR REPLACEMENT, OF ANY NOISE CONTROL DEVICE OR ELEMENT OF DESIGN (LISTED IN THE OWNER'S MANUAL) INCORPORATED INTO THIS COMPRESSOR IN COMPLIANCE WITH THE NOISE CONTROL ACT;

(B) THE USE OF THIS COMPRESSOR AFTER SUCH DEVICE OR ELEMENT OF DESIGN HAS BEEN REMOVED OR RENDERED INOPERATIVE.

DATE OF MANUFACTURE: 049463

2004	2005	2006	2007	2008	2009	2010	2011	2012	2013	2014	2015																			
JAN	FEB	MAR	APR	MAY	JUN	JUL	AUG	SEP	OCT	NOV	DEC																			
1	2	3	4	5	6	7	8	9	10	11	12	13	14	15	16	17	18	19	20	21	22	23	24	25	26	27	28	29	30	31

15

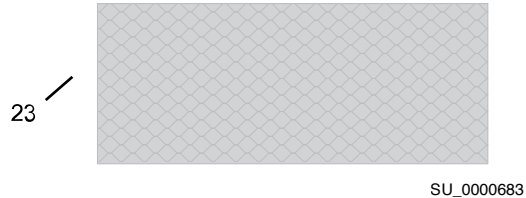
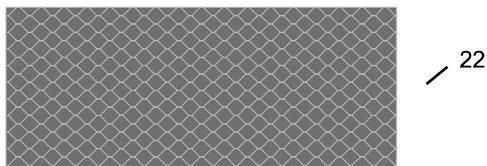
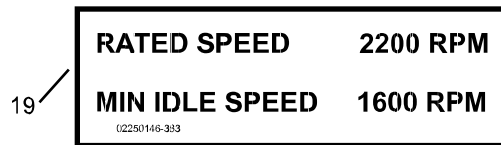
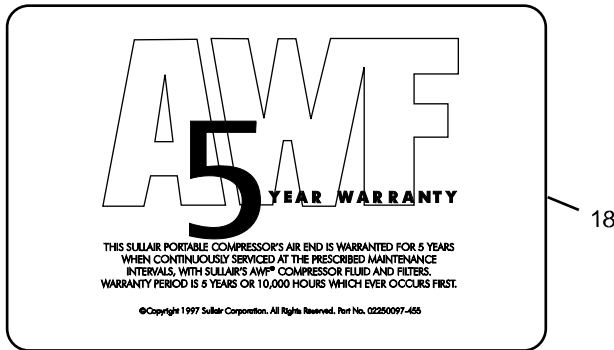

SU_0000683

7.19 DECALS (CONTINUED)

Key	Description	Part Number	Note	Quantity
14	decal, caution do not overfill	02250142-530		1
15	decal, noise emission control	049463		1
18	decal, 5 year warranty	02250097-455		1
19	decal, rated 2200 idle 1600 rpm	02250146-383		1
22	reflector, red	040103		2
23	reflector, amber	250034-319		2

7.19 DECALS (CONTINUED)

300HH



24

375



25

375H



27

425



28



30



31



33



34



36



37

SU_0000684

7.19 DECALS (CONTINUED)

Key	Description	Part Number	Note	Quantity
24	decal, "300HH Sullair" frnt blk	02250139-154		1
25	decal, "375 Sullair" frnt blk	02250117-349		1
27	decal, "375H Sullair" frnt blk	02250117-352		1
28	decal, "425 Sullair" frnt blk	02250118-606		1
30	decal, "300HH" 3" tall blk	02250165-929		1
31	decal, "375" 3" tall blk	02250165-927		1
33	decal, "375H" 3" tall blk	02250165-928		1
34	decal, "425" 3" tall blk	02250165-930		1
36	decal, Sullair 3 x 24 blk	02250059-056		1
37	decal, ISO 9001	02250057-624		1

7.19 DECALS (CONTINUED)

MAINTENANCE	MAINTENANCE KITS																										
<p>DAILY:</p> <ul style="list-style-type: none"> *CHECK ALL LIQUID LEVELS. *DRAIN WATER FROM FUEL-WATER SEPARATOR. <p>INITIAL 50 HOURS:</p> <ul style="list-style-type: none"> *CHANGE COMPRESSOR FLUID FILTER. *CLEAN THE RETURN LINE ORIFICE AND CHANGE THE STRAINER. <p>EVERY 50 HOURS:</p> <ul style="list-style-type: none"> *INSPECT AND REPLACE AIR FILTER ELEMENTS (IF REQUIRED). *CHECK FUEL FILTER FOR WATER. <p>EVERY 250 HOURS:</p> <ul style="list-style-type: none"> *CHANGE COMPRESSOR FLUID FILTER. *CLEAN THE RETURN LINE ORIFICE AND CHANGE THE STRAINER. *CHANGE THE ENGINE FUEL FILTER. *CHANGE THE ENGINE FUEL-WATER SEPARATOR. *CHANGE THE AIR FILTER ELEMENTS. *CHANGE THE ENGINE OIL. *CHANGE THE ENGINE OIL FILTER. <p>EVERY 500 HOURS:</p> <ul style="list-style-type: none"> *TEST THE ENGINE COOLANT. <p>EVERY 1500 HOURS OR ANNUALLY:</p> <ul style="list-style-type: none"> *CHANGE THE SEPARATOR ELEMENT *CHANGE THE COMPRESSOR FLUID. *CHANGE THE ENGINE COOLANT. <p>GENERAL:</p> <ul style="list-style-type: none"> *ANNUALLY OR EVERY 12K MILES, LUBRICATE AXLE BEARINGS. REFER TO SULLAIR OPERATORS MANUAL FOR GREASE GRADE AND PROCEDURE. 	<table border="1"> <thead> <tr> <th data-bbox="863 289 1182 331">DESCRIPTION</th> <th data-bbox="1188 289 1430 331">SULLAIR P/N</th> </tr> </thead> <tbody> <tr> <td data-bbox="863 331 1182 405">INITIAL 50 HOUR MAINTENANCE KIT</td> <td data-bbox="1188 331 1430 405">02250153-482</td> </tr> <tr> <td data-bbox="863 405 1182 478">250 HOUR MAINTENANCE KIT</td> <td data-bbox="1188 405 1430 478">02250168-403</td> </tr> <tr> <td data-bbox="863 478 1182 531">1500 HOUR OR ANNUAL MAINTENANCE KIT</td> <td data-bbox="1188 478 1430 531">02250168-404</td> </tr> <tr> <td colspan="2" data-bbox="863 531 1430 615">REFER TO SULLAIR MANUAL FOR INDIVIDUAL SERVICE KIT COMPONENT PART NUMBERS</td> </tr> </tbody> </table> <table border="1"> <thead> <tr> <th colspan="2" data-bbox="863 615 1430 678">REPAIR KITS</th> </tr> <tr> <th data-bbox="863 678 1182 720">DESCRIPTION</th> <th data-bbox="1188 678 1430 720">SULLAIR P/N</th> </tr> </thead> <tbody> <tr> <td data-bbox="863 720 1182 783">REGULATOR 100 PSI (375H, 300HH)</td> <td data-bbox="1188 720 1430 783">250019-453</td> </tr> <tr> <td data-bbox="863 783 1182 825">REGULATOR/BLOWDOWN MANIFOLD REPAIR KIT</td> <td data-bbox="1188 783 1430 825">02250151-201</td> </tr> <tr> <td data-bbox="863 825 1182 888">REGULATOR/BLOWDOWN MANIFOLD DIAPHRAGM KIT</td> <td data-bbox="1188 825 1430 888">02250150-183</td> </tr> <tr> <td data-bbox="863 888 1182 930">COMPRESSOR INLET VALVE</td> <td data-bbox="1188 888 1430 930">250029-249</td> </tr> </tbody> </table> <table border="1"> <thead> <tr> <th colspan="2" data-bbox="863 930 1430 993">LUBRICANTS</th> </tr> </thead> <tbody> <tr> <td colspan="2" data-bbox="863 993 1430 1094">REFER TO SULLAIR AND CATERPILLAR MANUALS FOR COMPRESSOR & ENGINE LUBRICATING OIL RECOMMENDATIONS. 02250165-935 REV 00</td> </tr> </tbody> </table>	DESCRIPTION	SULLAIR P/N	INITIAL 50 HOUR MAINTENANCE KIT	02250153-482	250 HOUR MAINTENANCE KIT	02250168-403	1500 HOUR OR ANNUAL MAINTENANCE KIT	02250168-404	REFER TO SULLAIR MANUAL FOR INDIVIDUAL SERVICE KIT COMPONENT PART NUMBERS		REPAIR KITS		DESCRIPTION	SULLAIR P/N	REGULATOR 100 PSI (375H, 300HH)	250019-453	REGULATOR/BLOWDOWN MANIFOLD REPAIR KIT	02250151-201	REGULATOR/BLOWDOWN MANIFOLD DIAPHRAGM KIT	02250150-183	COMPRESSOR INLET VALVE	250029-249	LUBRICANTS		REFER TO SULLAIR AND CATERPILLAR MANUALS FOR COMPRESSOR & ENGINE LUBRICATING OIL RECOMMENDATIONS. 02250165-935 REV 00	
DESCRIPTION	SULLAIR P/N																										
INITIAL 50 HOUR MAINTENANCE KIT	02250153-482																										
250 HOUR MAINTENANCE KIT	02250168-403																										
1500 HOUR OR ANNUAL MAINTENANCE KIT	02250168-404																										
REFER TO SULLAIR MANUAL FOR INDIVIDUAL SERVICE KIT COMPONENT PART NUMBERS																											
REPAIR KITS																											
DESCRIPTION	SULLAIR P/N																										
REGULATOR 100 PSI (375H, 300HH)	250019-453																										
REGULATOR/BLOWDOWN MANIFOLD REPAIR KIT	02250151-201																										
REGULATOR/BLOWDOWN MANIFOLD DIAPHRAGM KIT	02250150-183																										
COMPRESSOR INLET VALVE	250029-249																										
LUBRICANTS																											
REFER TO SULLAIR AND CATERPILLAR MANUALS FOR COMPRESSOR & ENGINE LUBRICATING OIL RECOMMENDATIONS. 02250165-935 REV 00																											

7.19 DECALS (CONTINUED)

Key	Description	Part Number	Note	Quantity
39	decal, maint 300HH-425 cat t3	02250165-935		1

7.19 DECALS (CONTINUED)

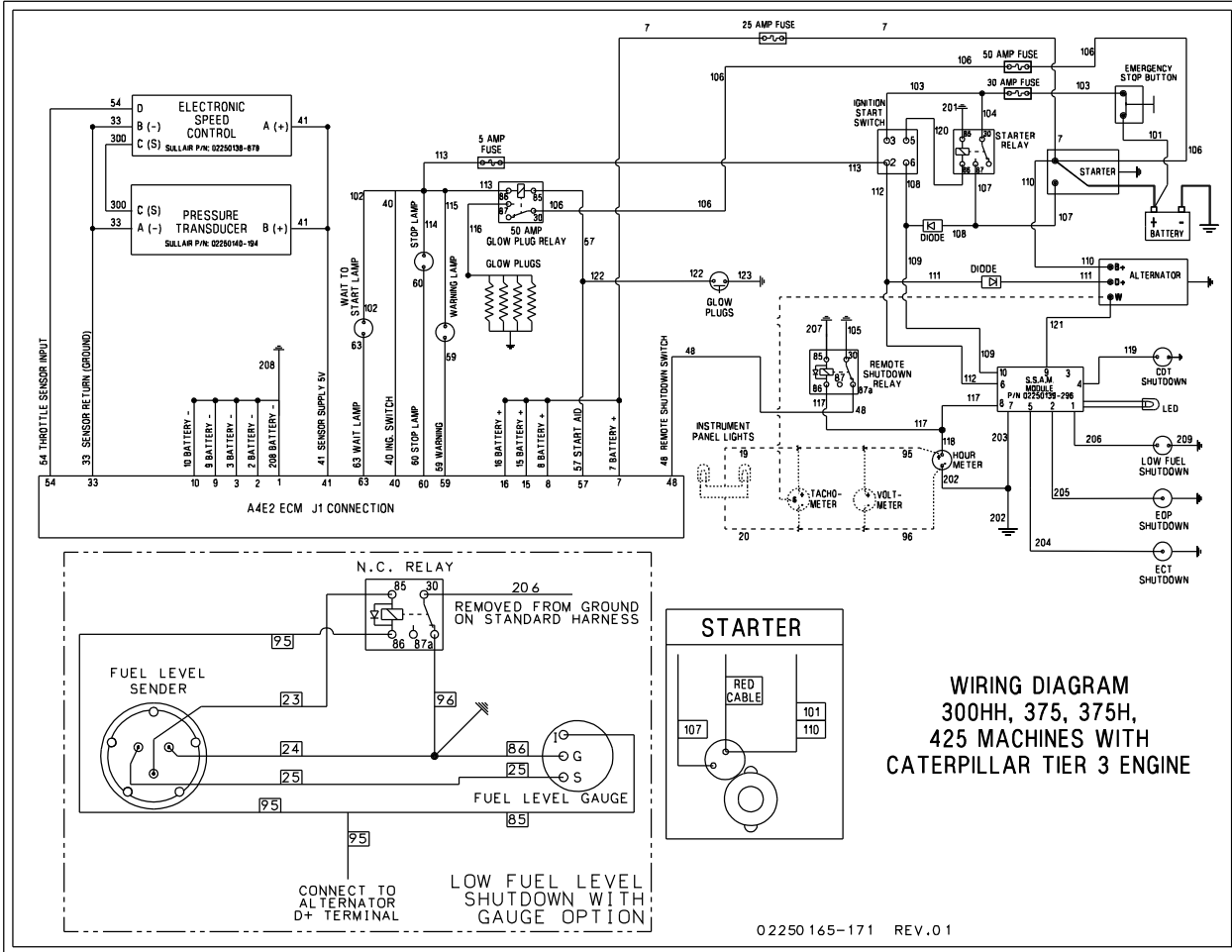

AFTERCOOLED AND FILTERED AIR

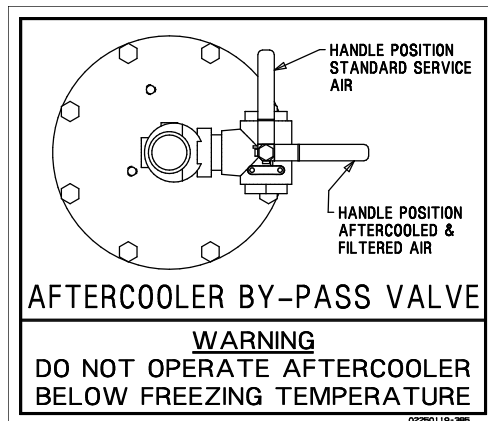

02250075-505-r00

02250119-385-r01

7.19 DECALS (CONTINUED)

Key	Description	Part Number	Note	Quantity
40	decal, wd e & c 375-425 cat t3	02250165-171		1
41	decal, aftercooled/filtered air	02250075-506		1
42	decal, aftercooler by-pass valve	02250119-385		1

7.20 DECAL LOCATIONS

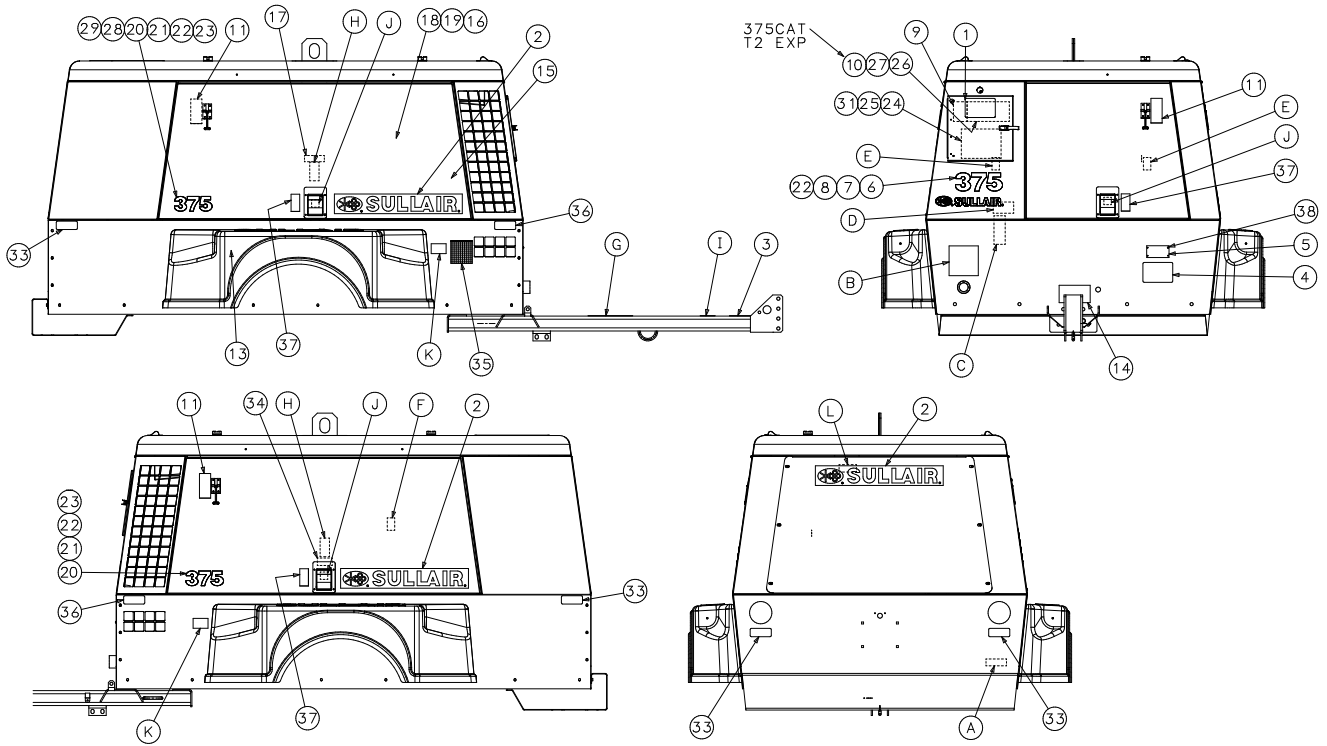

7.20 DECAL LOCATIONS (CONTINUED)

Key	Description	Part Number	Note	Quantity
1	decal, iso 9001 blk 3.44x5.75	02250057-624		1
2	decal, "Sullair" 3.0 x 24.0	02250059-056		3
3	decal, warning tongue heavy 100-375	02250077-929	(I)	1
4	decal, 5 year warranty	02250097-455		1
5	nameplate, Sullair serial no. 185q-8f	02250108-078		1
6	decal, "375 Sullair" frt blk	02250117-349		1
7	decal, "375H Sullair" frt blk	02250117-352		1
8	decal, "425 Sullair" frt	02250118-606		1
9	decal, lead warning proposition 65	02250118-638		1
11	decal, warning side door t-latch	02250136-670		3
12	decal, "300HH Sullair" frt blk	02250139-154		1
13	decal, "need an air tool?" sml	02250140-925		1
14	decal, drwbr instl 185q pe std	02250142-050	(I)	1
15	decal, caution- do not overfill	02250142-530		1
17	decal, rated 2200 idle 1600	02250146-383		1
19	decal, wiring diagram 375-425 cat t3	02250165-171		1
20	decal, "375" 3" tall blk	02250165-927		2
21	decal, "375H" 3" tall blk	02250165-928		2
22	decal, "300HH" 3" tall	02250165-929		2
23	decal, "425" 3" tall blk	02250165-930		2
24	decal, maintenance 375-425 cat t3	02250165-935		1
26	decal, operator procedure start stop 375 cat t3	02250165-938		1
28	decal, "375HH" 3" tall blk	02250168-422		2
33	reflector, red 1.68 x 4.25	040103		4
34	decal diesel fuel	040248		1
35	decal, noise emission control	049463		1
36	reflector, amber 1.68 x 4.25	250034-319		2
37	sign, warning-hot surfaces	407408		3
38	rivet, pop 1/8 x 3/8	843102-038		1

7.20 DECAL LOCATIONS

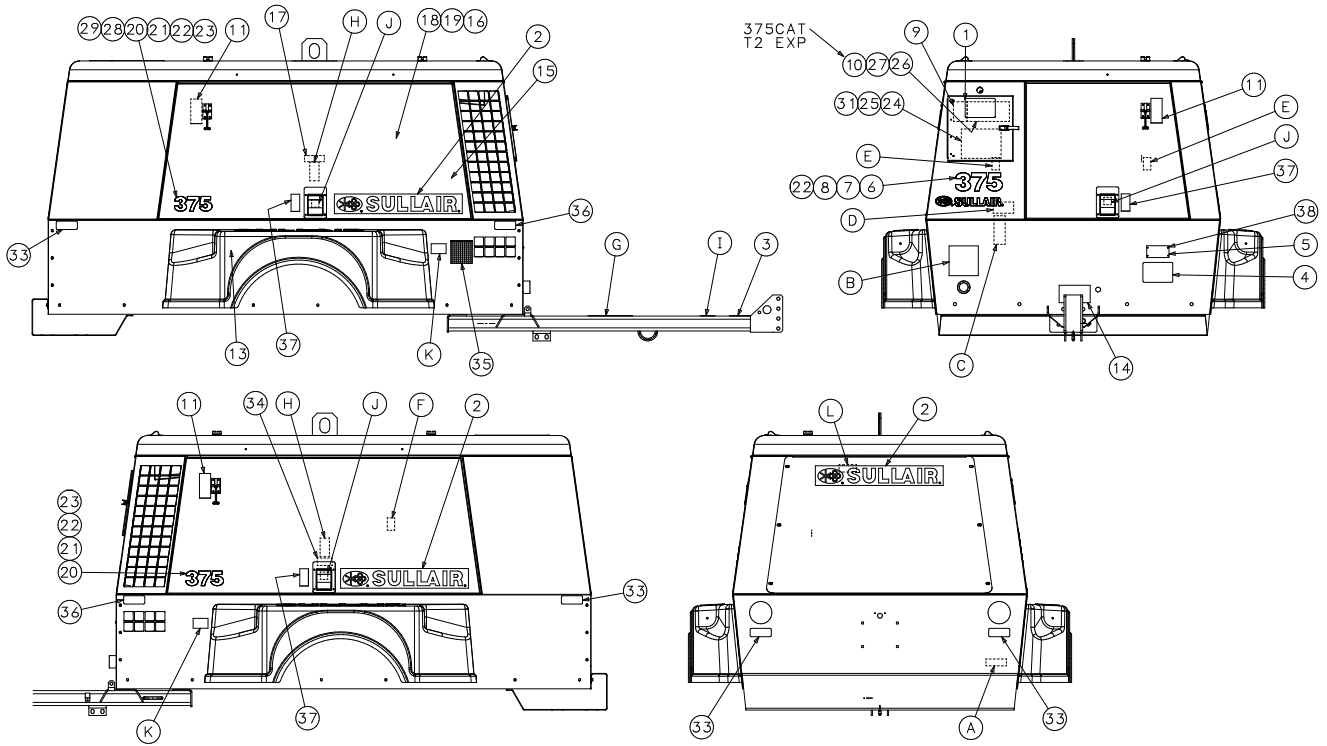

7.20 DECAL LOCATIONS (CONTINUED)

Key	Description	Part Number	Note	Quantity
A	decal, water drain	040345		2
B	decal, warning cluster breath	250028-258		1
C	sign, warning compr oil fill cap	049685		1
D	decal, sullair awf instruction	250032-902		1
E	sign, warning sever fan port	049965		2
F	sign, warning sever belt drive	049964		1
G	sign, caution towing 55 mph	250005-578	(I)	1
H	sign, warning hot surfaces	407408		2
I	sign, warning crush/sever	408919	(I)	1
J	decal, caution doors closed	250038-030		4
K	axle lube instructions	250042-543	(I)	2
L	decal, warning pressurized clg sys	02250051-826		1

location

- A one on engine near drain, one on rear baffle near radiator drain
- B shown -over service valves
- C on receiver near fluid fill cap
- D on receiver near fluid fill cap
- E one on each side of fan shroud
- F on alternator
- G shown -on top of drawbar
- H one on each side of lifting bail
- I shown -on top of drawbar
- J shown -one on back of each door latch
- K shown-one at upper rear of fenders
- L shown-on baffle over radiator fill

(I) This decal not used on less running gear machines.

THIS PAGE INTENTIONALLY LEFT BLANK

 **WARNING****CALIFORNIA****Proposition 65 Warning**

Diesel engine exhaust and some of its constituents are known to the State of California to cause cancer, birth defects and other reproductive harm.

Battery posts, terminals and related accessories contain lead and other compounds known to the State of California to cause cancer and birth defects and other reproductive harm. Wash hands after handling.

02250118-633



WORLDWIDE SALES AND SERVICE

SULLAIR ASIA, LTD.

Sullair Road, No. 1
Chiwan, Shekou
Shenzhen, Guangdong PRV.
PRC POST CODE 518068
Telephone: 755-6851686
Fax: 755-6853473
www.sullair-asia.com

SULLAIR CORPORATION

3700 East Michigan Boulevard
Michigan City, Indiana 46360 U.S.A.
www.sullair.com
Telephone: 1-800-SULLAIR (U.S.A. Only)
or 1-219-879-5451
Fax: (219) 874-1273

SULLAIR EUROPE, S.A.

Zone Des Granges BP 82
42602 Montbrison Cedex, France
Telephone: 33-477968470
Fax: 33-477968499
www.sullaireurope.com

CUSTOMER CARE PARTS

1-888-SULLAIR (785-5247)
Fax: (219) 874-1835
www.sullair.com

SERVICE

1-888-775-1604 (U.S.A. & Canada Only)
Fax: (219) 874-1205
www.sullair.com

CHAMPION COMPRESSORS, LTD.

Princess Highway
Hallam, Victoria 3803
Australia
1800-810-015
(for Australia wide branch network only)
Telephone: 61-3-9796-4000
Fax: 61-3-9703-8053
www.championcompressors.com.au